



# Rowan Patents Preparation Drawing Tool User Manual

Also available online:

**Rowan Patents Core User Manual**

**Rowan Patents Preparation Bio/Chem/Pharma Features User Manual**

<https://rowanpatents.com/drafting-user-manual/>

All information in this manual is also available and evergreen in our online help library at

<https://intercom.help/rowanpatents/en/collections/1625737>

# Table of Contents

Quick Guide.....	4
Open the Drawing Tool.....	6
Navigate to a Specific Figure.....	9
Merge Rowan Patents Figures into a Different Rowan File.....	13
Import Visio Drawings.....	16
Import PDF Drawings.....	19
Import Drawings from Patent Publications.....	21
Add a Figure from Markdown Code.....	24
Add a New Figure.....	25
Import a Background Image.....	32
Crop Imported Image.....	33
Lock Elements to the Drawing Canvas.....	35
Stamp Identical Stencils.....	35
Rotate Drawing Sheet Orientation.....	37
Adjust Drawing Canvas Zoom.....	42
Use and Adjust Canvas Grid and Guides.....	44
Subnumber Figures.....	45
Reorder Figure Sheets.....	48
Move Figures to Other Sheets.....	52
Export Drawing Sheet(s) as a New .rp File.....	53
Delete a Figure or Sheet.....	54
Create New Parts.....	57
Select Autonumbering Mode for Parts.....	59
Change Part Autonumbering Increment.....	61
Select Manual Numbering Mode for Parts.....	64
Create a Figure (X00) Part.....	66
Select Multiple Parts.....	69
Reorder Parts and Move Parts to a Different Figure.....	70
Merge Parts.....	72
Subnumber Parts.....	77
Convert a Part Name to a Term.....	81
Edit Part Name Pluralization.....	83
Filter and Collapse Parts Panel Lists.....	85
Delete Parts.....	87
Add Elements to a Drawing Canvas.....	90
Select Stencils and Connector Lines.....	97

Move Stencils Around the Drawing Canvas.....	100
Assign/Remove Part Data and Labels for a Figure Element.....	102
Adjust Stencil Part Number Placement.....	109
Adjust Text Case and Alignment.....	111
Change Stencil to a Different Stencil Type.....	113
Modify a Stencil's Shape.....	115
Import a Drawing Stencil.....	117
Adjust Stencil Styles.....	120
Resize Stencils.....	122
Rotate Stencils and Stencil Text.....	124
Align and Distribute Stencils.....	127
Change Overlap Order of Elements on the Drawing Canvas.....	128
Group Stencils.....	129
Adjust Connector Line Styles.....	131
Adjust Connector Line Routing.....	133
Create Flowchart Steps from Stencils.....	138
Create Flowchart Steps from the Claims Panel.....	140
Add a Flowchart Step Description.....	143
Add a Flowchart Step Component.....	148
Adjust Used Element Highlighting in the Drawing Tool Claims Panel.....	149
Remove/Apply Layout-Based Flowchart Numbering.....	150
Add a Mathematical Expression to a Figure.....	152
Add a Table to a Figure.....	153
Delete a Stencil or Connector Line.....	155
Get Help or Provide Feedback.....	157

# Quick Guide

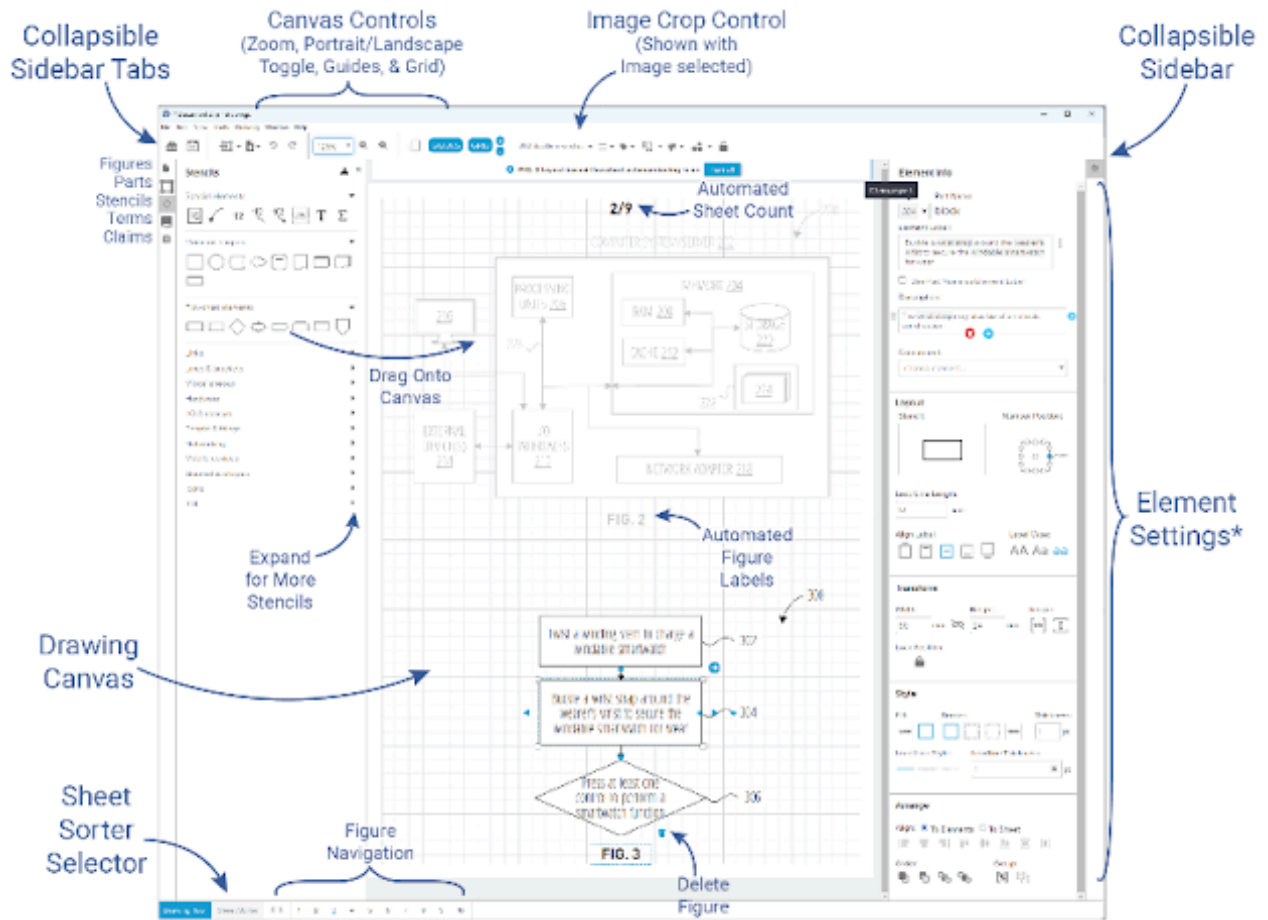

## Parts Management in the Parts Panel

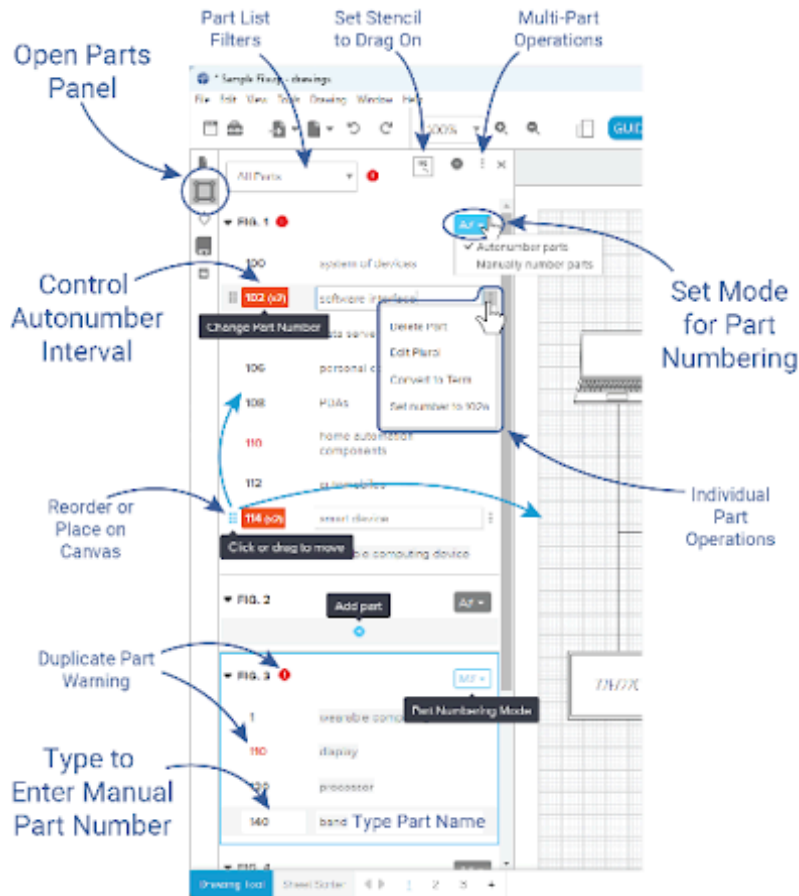

## Figure Settings\* (Shown with Figure Label Selected)



## Link Settings\* (Shown with Link Selected)

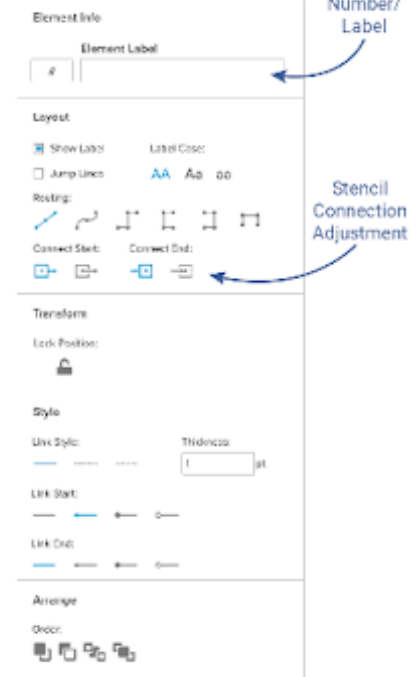

## Figure and Sheet Management in the Sheets Panel

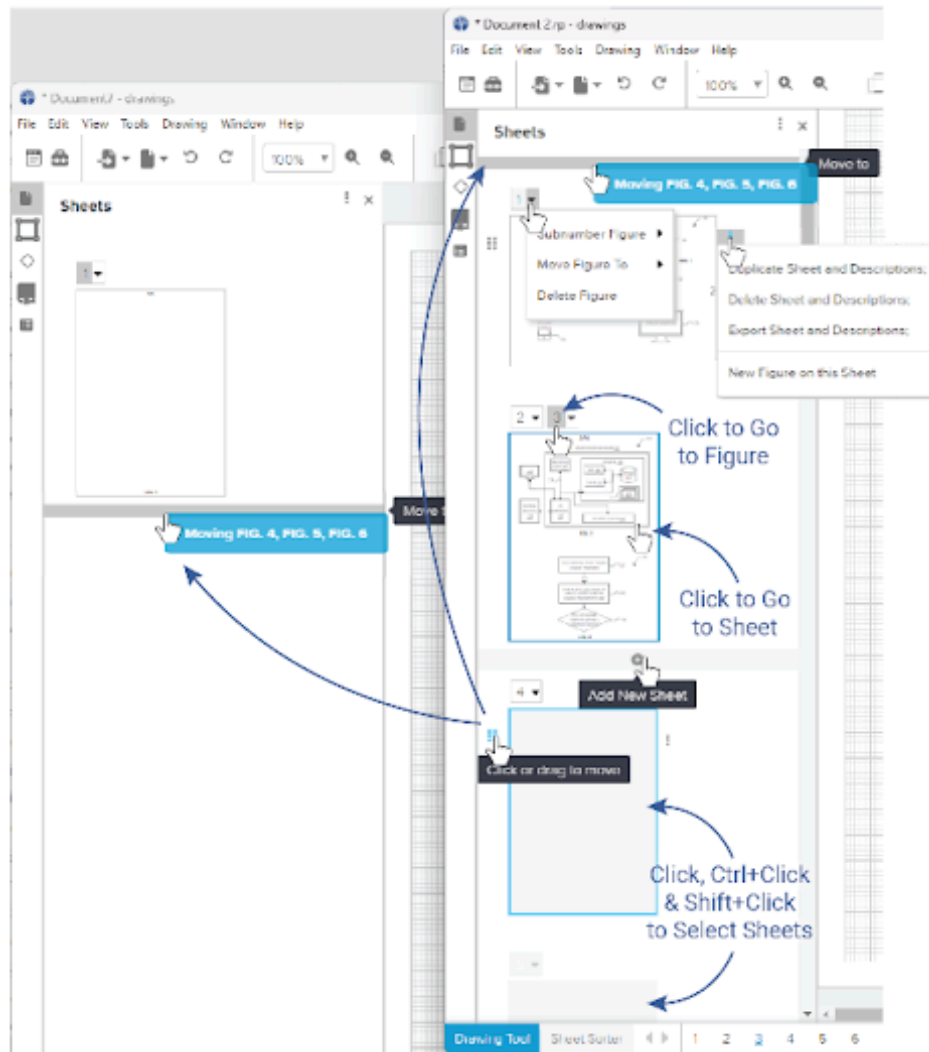

## Open the Drawing Tool

### Open from Toolbar Buttons

1. Open your .rp file.
2. Click the Drawings button in the main application window toolbar.

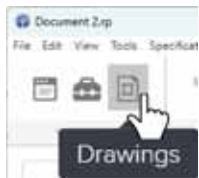

3. The Drawing Tool will open to display the first sheet of figures in your application.

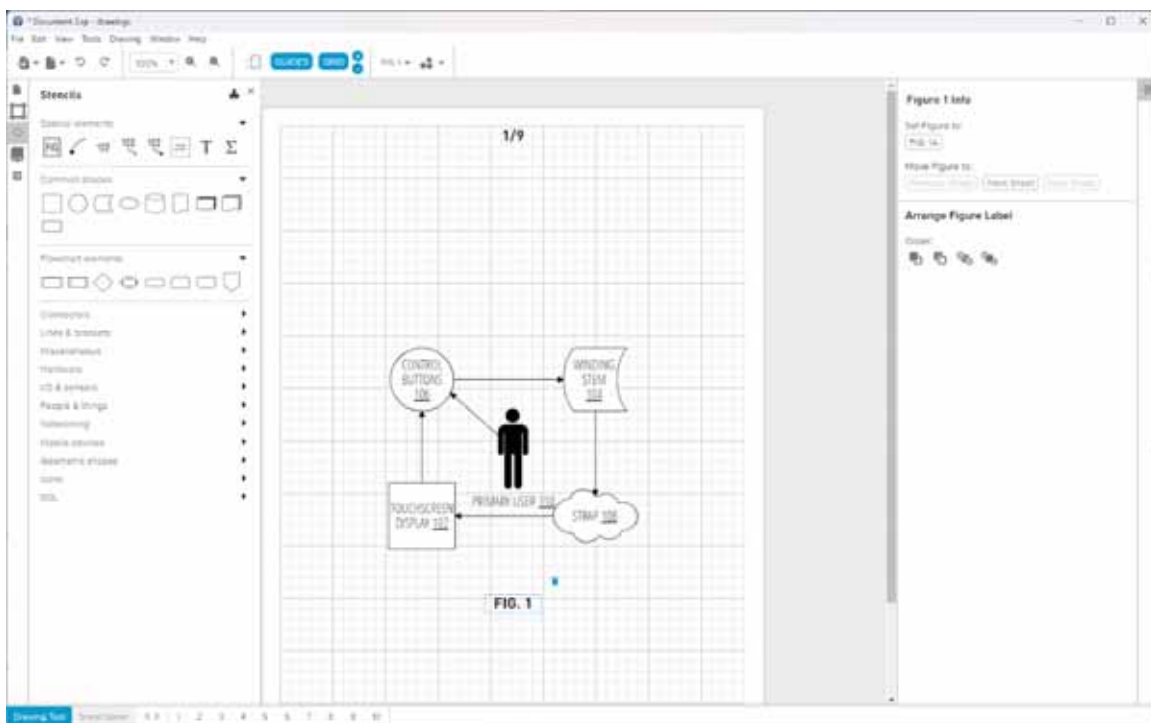

## Open from Menus

1. Open your .rp file.
2. Click the Drawing Tool option in either the Tools menu or Drawings menu.

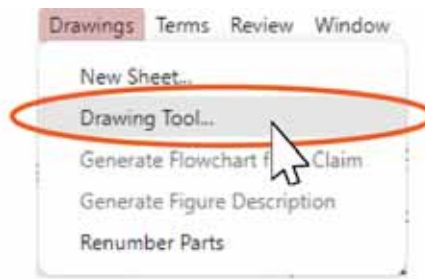
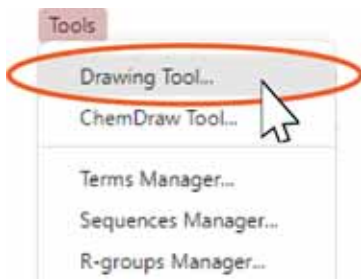

3. The Drawing Tool will open to display the first sheet of figures in your application.

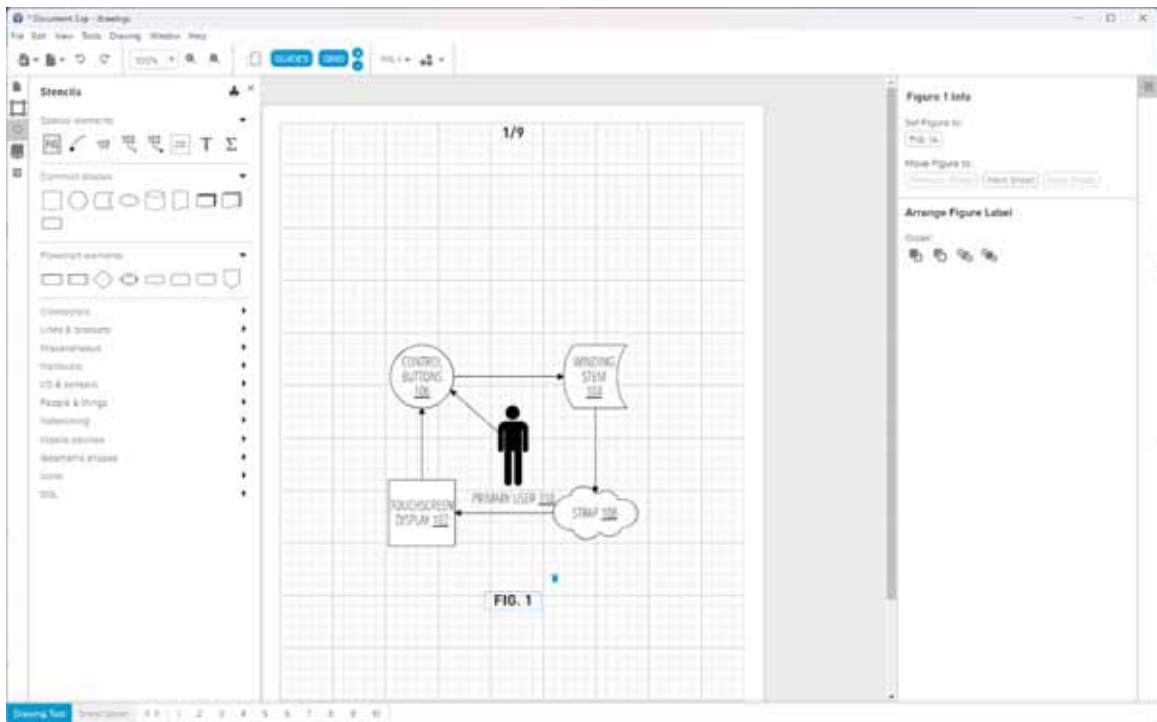

## Open from Previews

1. Navigate to the drawing previews at the bottom of the main application window and locate the desired figure.
2. Click the Edit in Drawing Tool icon at the top of the preview

OR with the Edit in Drawing Tool icon selected, click anywhere on the figure preview.

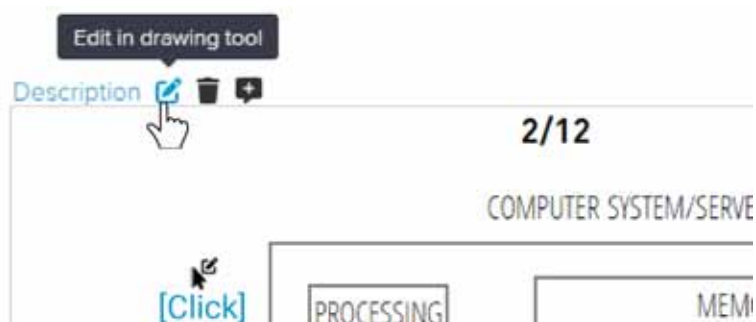



3. The Drawing Tool will open displaying the clicked figure.

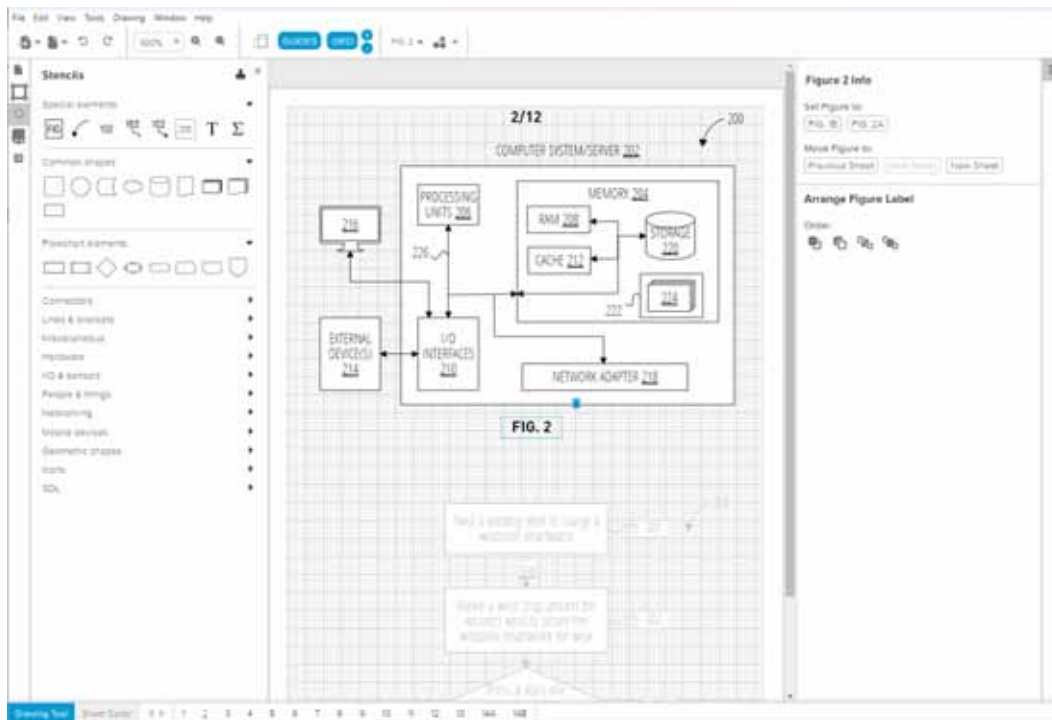

## Navigate to a Specific Figure

### Footer Navigation

1. Open the Drawing Tool.
2. Click the number for your desired figure among the navigation links in the Drawing Tool window footer.

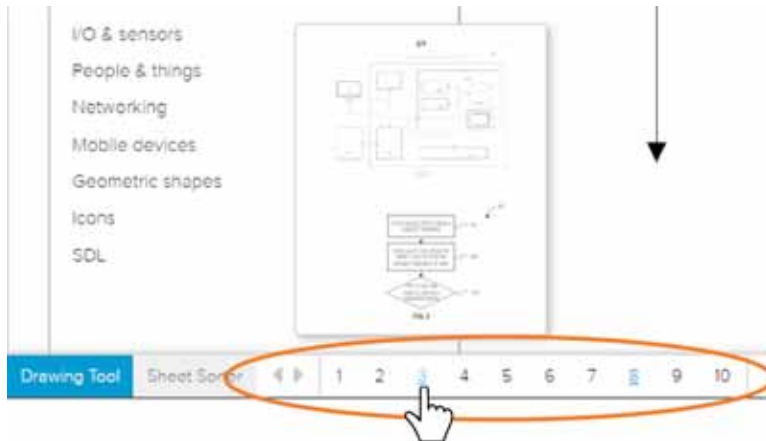

*Hovering over a number in the footer listing will cause a preview thumbnail to appear.*

3. If the desired figure number isn't visible, use the arrows to the left to navigate along the listing in the footer.

## Sheets Panel Navigation

1. Open the Drawing Tool.
2. Click the Sheets panel option in the left-hand sidebar.
3. Scroll if needed to locate the desired sheet/figure.
4. Click a thumbnail to bring the displayed sheet to the drawing canvas

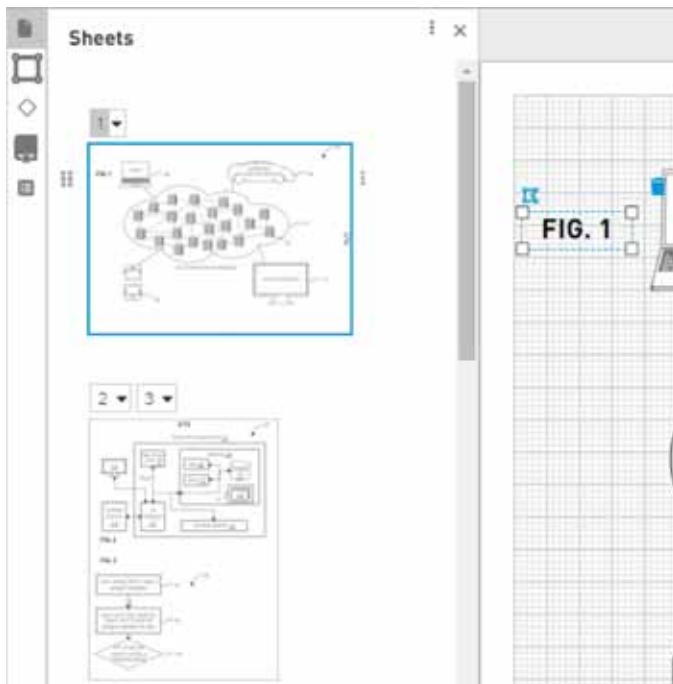
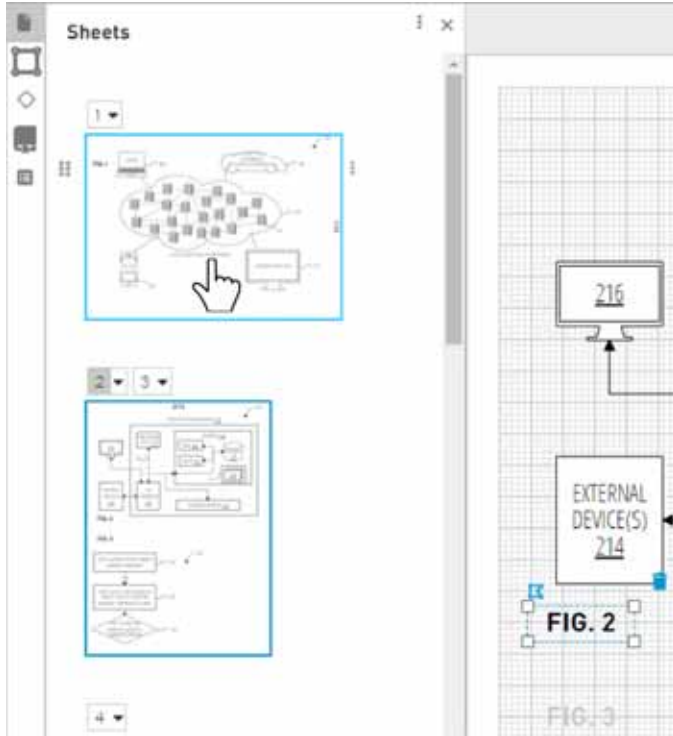

OR Click a figure number to bring the sheet for that figure to the drawing canvas with the figure in focus.

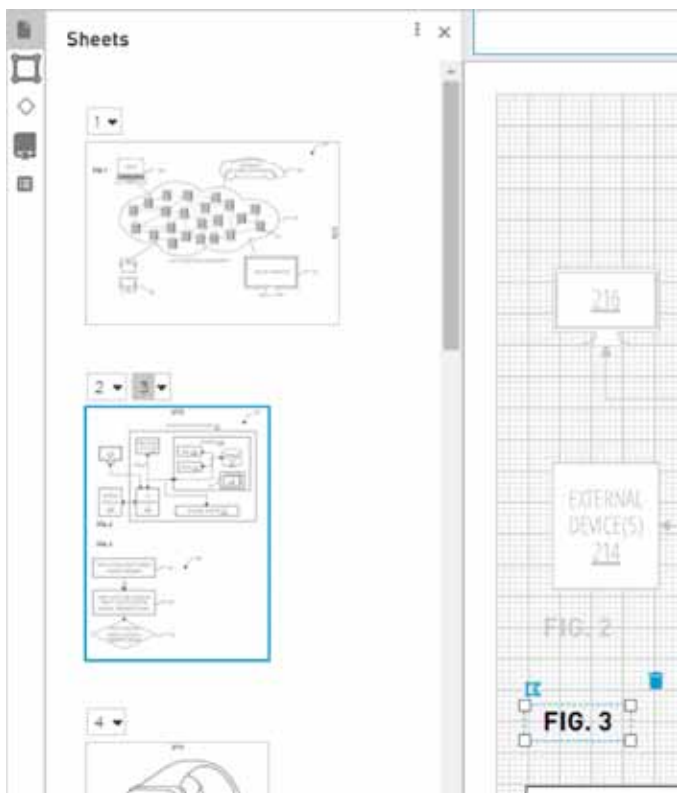
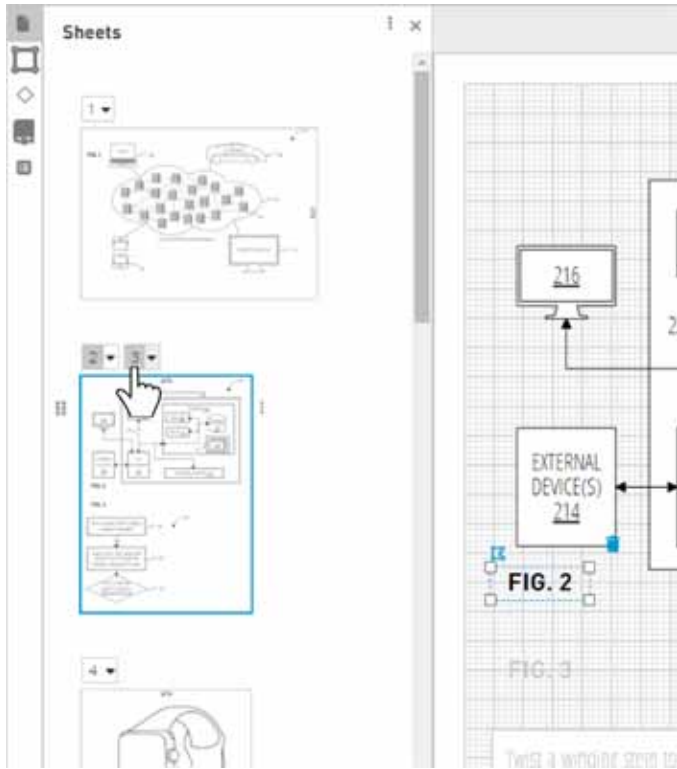

# Merge Rowan Patents Figures into a Different Rowan File

## Merging One or More Figures with the Sheets Panel

1. Open your source file and your target file.
2. Open the Drawing Tool for both files.
3. Open the Sheets panel in the left-hand sidebar for both files.
4. Click, Ctrl+Click (Cmd-Click for Mac users), and Shift+Click to select the thumbnail(s) provided in your source file Sheets panel for the figure(s) you wish to merge into your target file.
5. Click the drag handle to the left of a selected thumbnail and drag your selected figure(s) to the Sheets panel for your target file.
6. Hover in the area where you wish to insert the figure(s) to reveal an insertion bar at that location.
7. When the insertion bar appears, release the mouse to drop the figure(s) there.

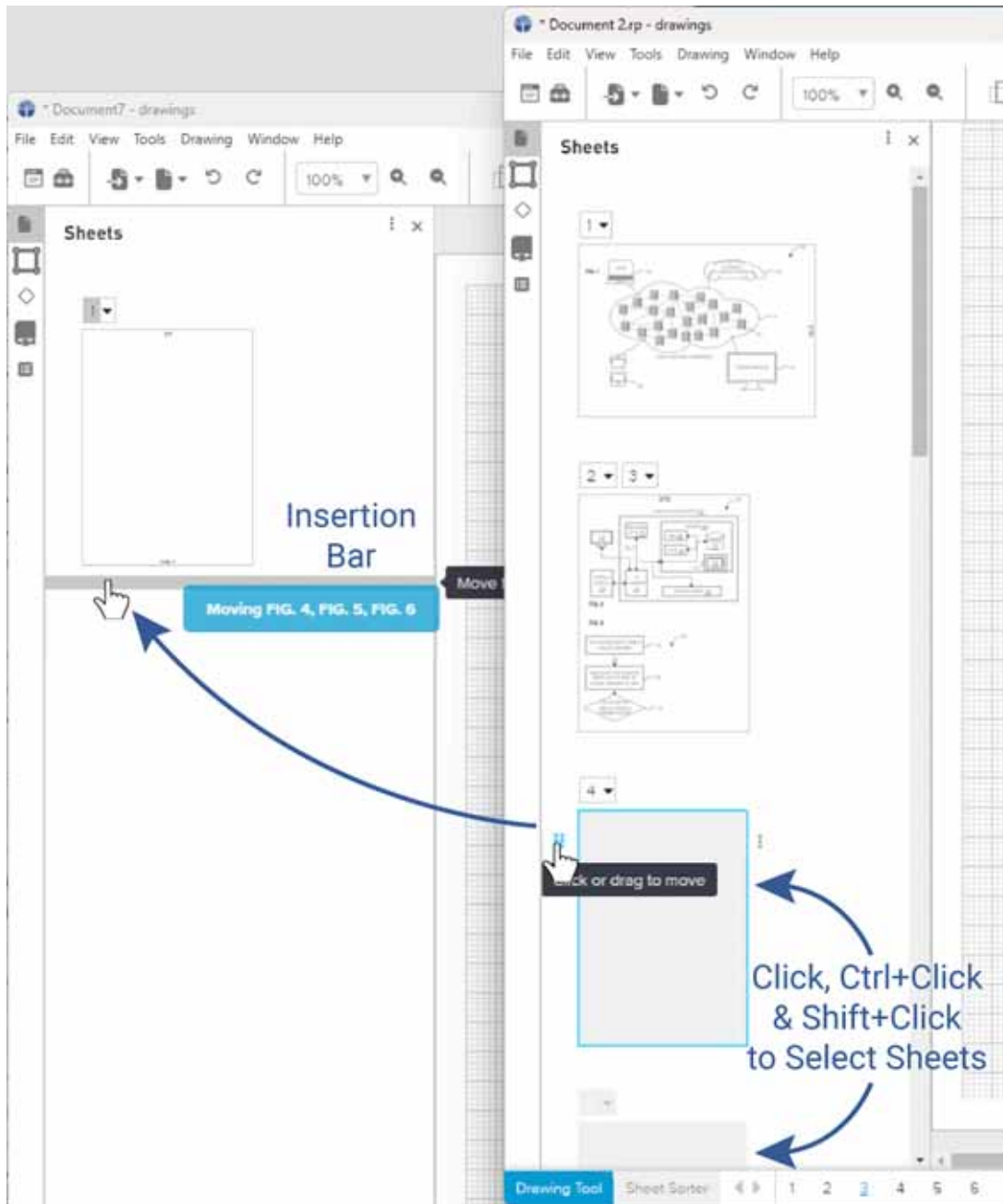

## Merging Individual Figures with the Sheet Sorter

1. Open your source file and your target file.
2. Open the Drawing Tool for both files.

3. Open the Sheet Sorter view in both files.

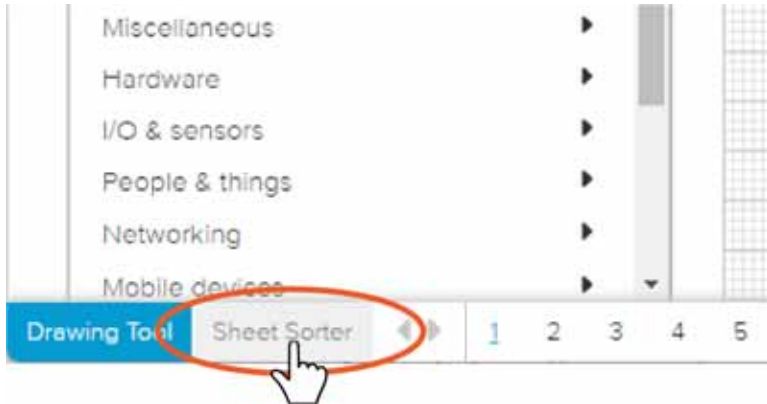

4. Click and drag the desired figure thumbnail in the source file Sheet Sorter, and drop it onto the Sheet Sorter in your target document. A blue line will indicate the point where your figure will drop.

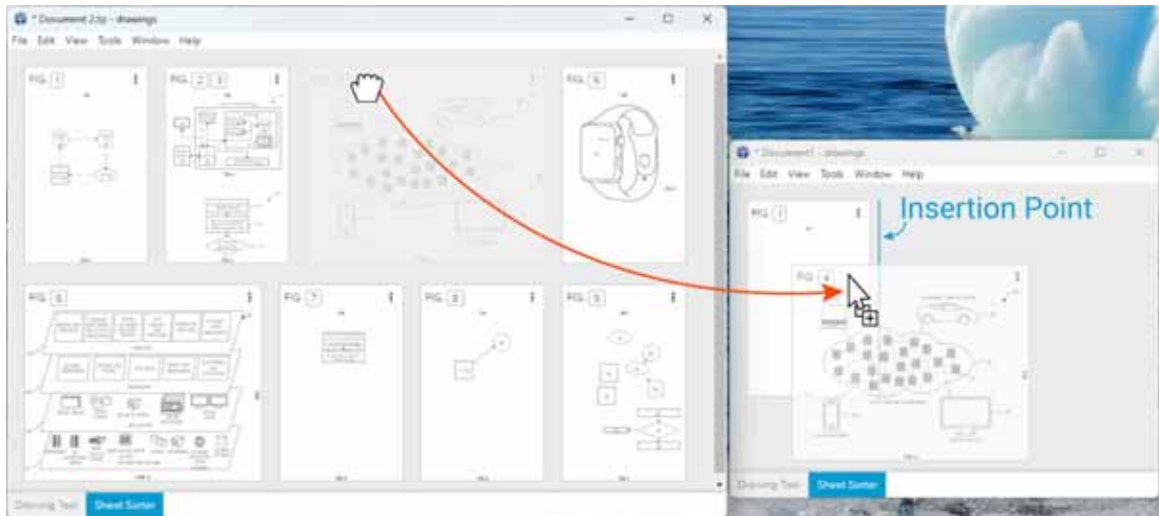

*Associated specification content and terms will be merged along with the figure.*

5. Click the Drawing Tool tab in the lower left corner to return to the first sheet of figures. Click the figure number icon to go to that figure in the Drawing Tool view.

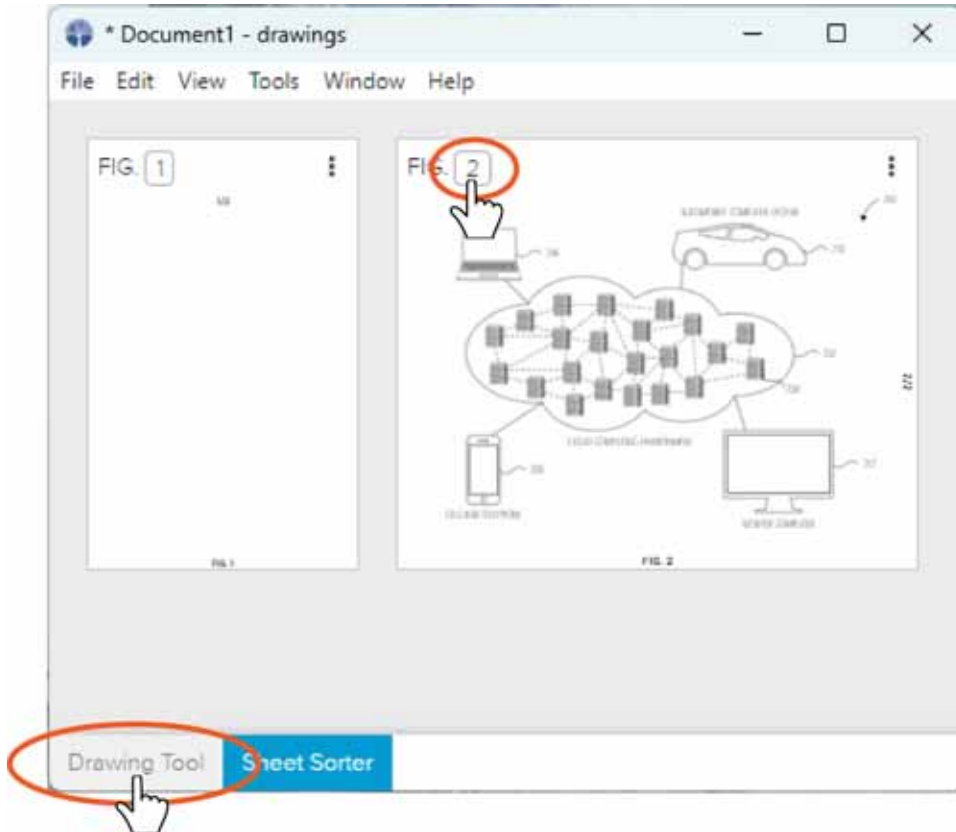

*You can edit, delete, or otherwise modify the figure in your target document as desired using the Drawing Tool. No link is maintained to the source object; changes in the target document will not be reflected in the source.*

## Import Visio Drawings

1. Open the Drawing Tool.
2. Select the From File (.pdf or .vsdx) option under the Import dropdown control in the toolbar or under the Drawing menu.



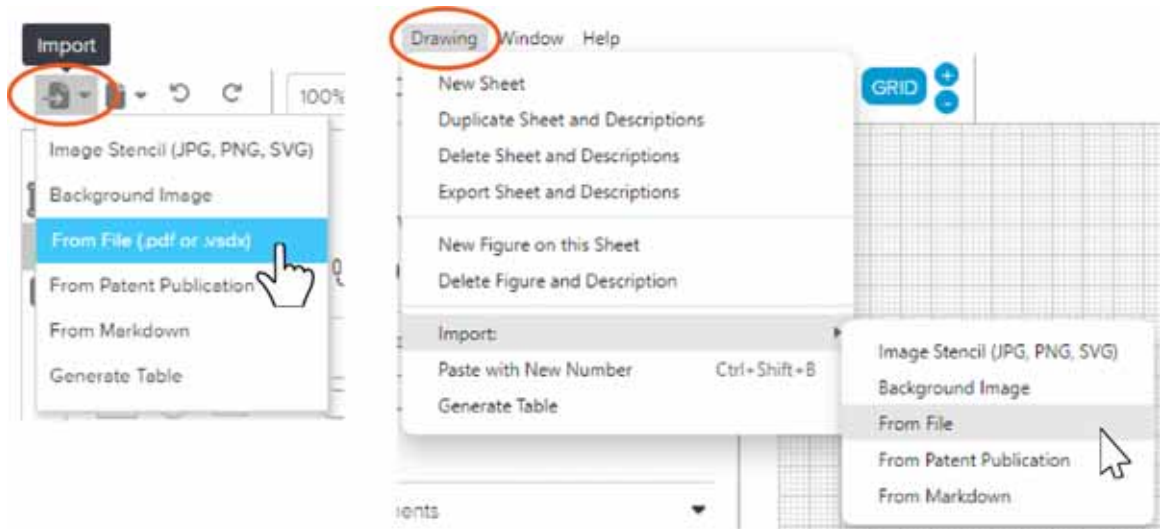

3. Drag and drop or browse for the file you wish to convert in the resulting dialog.

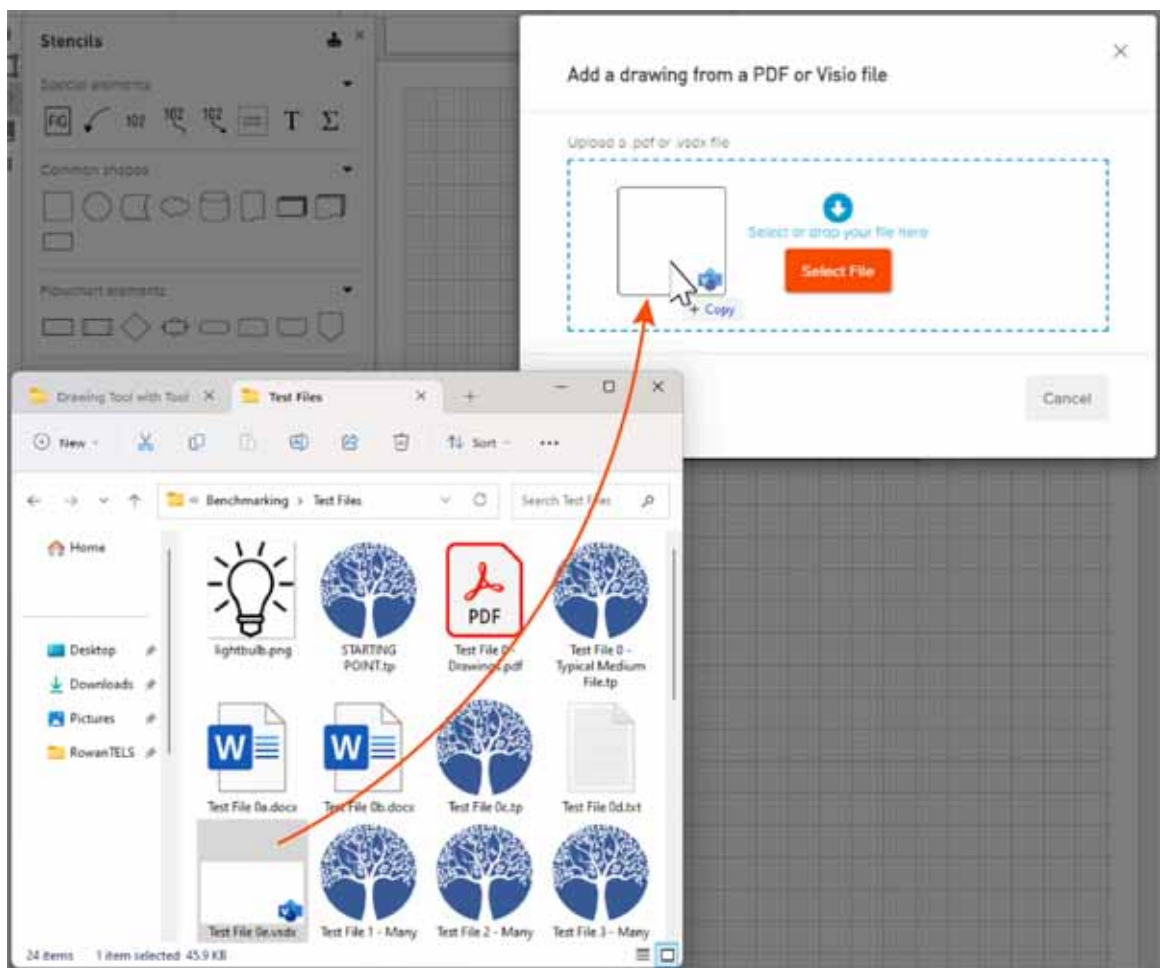

- Each tab of your Visio file will import as a new sheet at the end of your current set of figures. If multiple figures are labeled on a tab, they will import as consecutively numbered figures on one sheet.

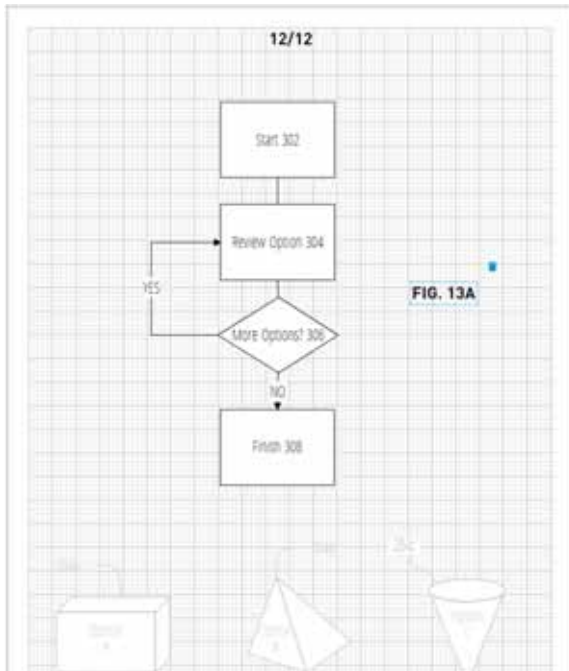

- Reorder your sheets if desired.

*We make every effort to preserve existing drawing work during import, including connector and border styling, part names, and where possible, part numbers.*

*However, the complexities of providing a third-party integration mean that imported Visio elements may not always translate to the Rowan element you want, and changes or updates in Visio encoding may disrupt our ability to correctly display some styles.*

*We encourage you to closely review imported drawings. If you have any issues, please don't hesitate to reach out to us through the Rowan Help menu, by contacting your Rowan Account Manager, or by emailing us at [feedback@rowantels.com](mailto:feedback@rowantels.com), so that we can work with you to improve your Visio import experience in every way.*

# Import PDF Drawings

1. Open the Drawing Tool.
2. Select the From File (.pdf or .vsdx) option under the Import dropdown control in the toolbar or under the Drawing menu.

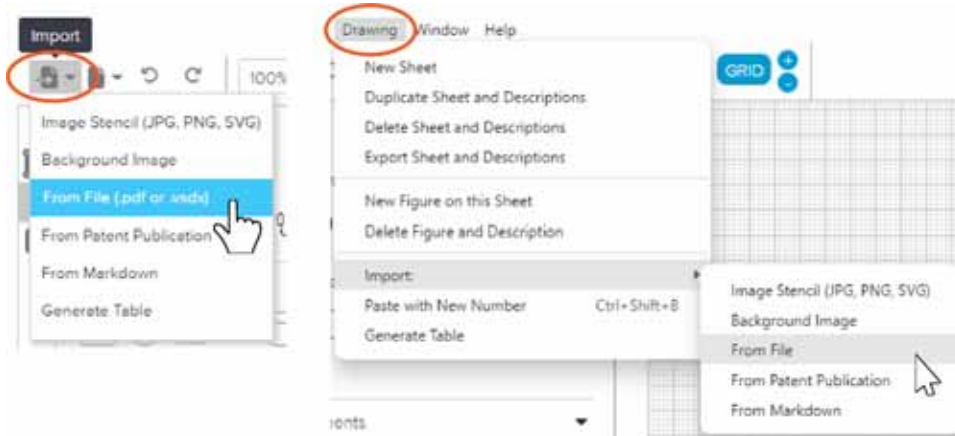

3. Drag and drop or browse for your desired PDF in the dialog provided.

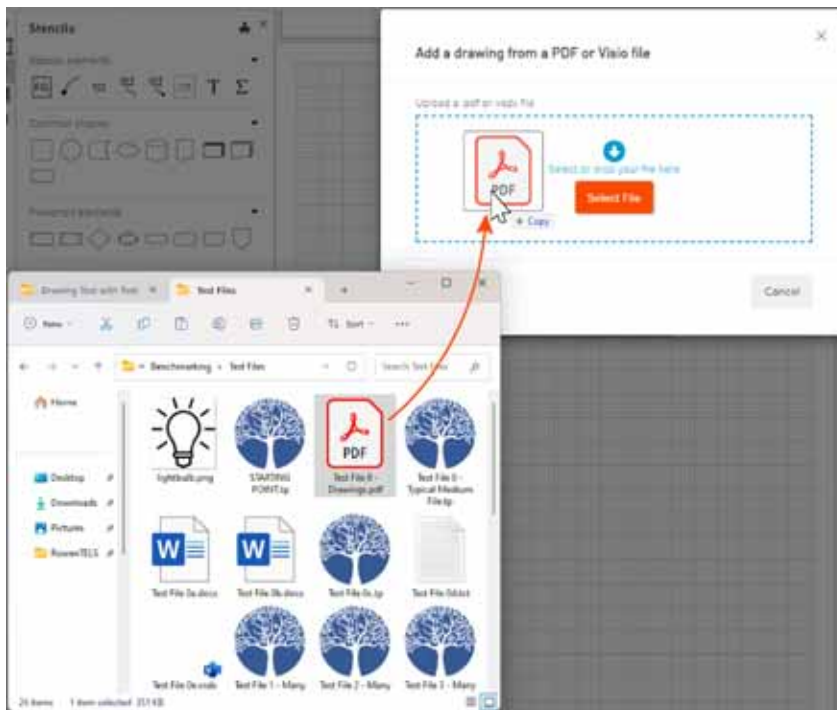

4. Select the pages you wish to import from the dialog provided by clicking Select All, Deselect All, and the individual page thumbnails as needed.

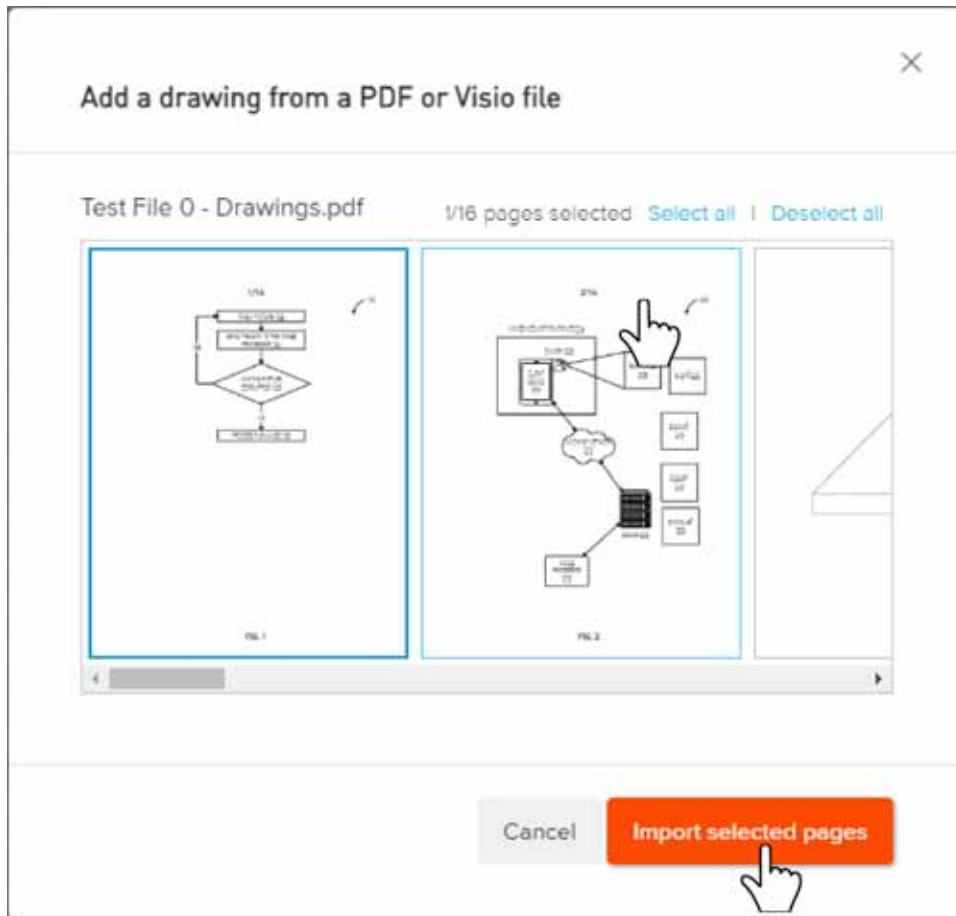

*We will attempt to detect all pages containing figures and drawings rather than numerous text paragraphs, and our results will be selected by default.*

5. Click the Import selected pages button.
6. Each selected page of your PDF will be populated as a background image on a new figure sheet.

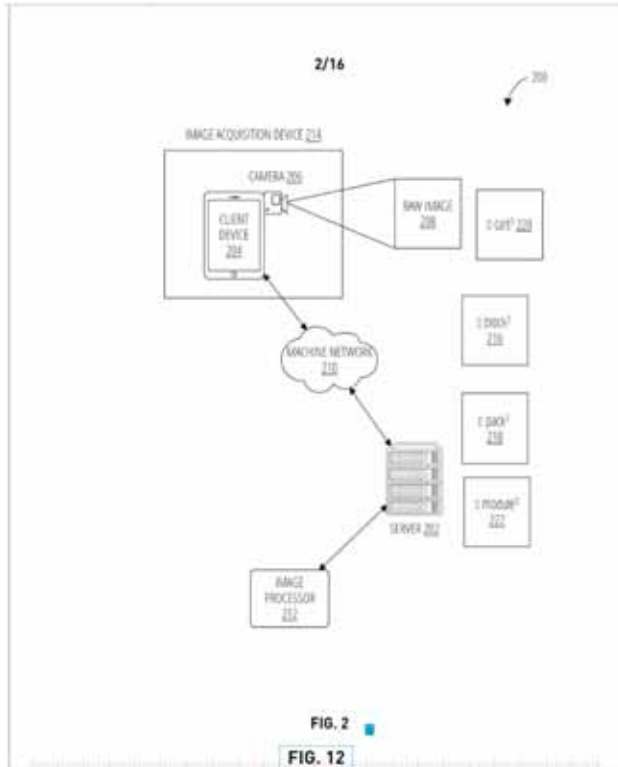

7. Crop out or cover any elements you do not wish to be shown, as needed. Group elements and lock elements to the canvas as needed.

## Import Drawings from Patent Publications

1. Open the Drawing Tool.
2. Select the From Patent Publication option under the Import dropdown in the toolbar or under the Drawings menu.

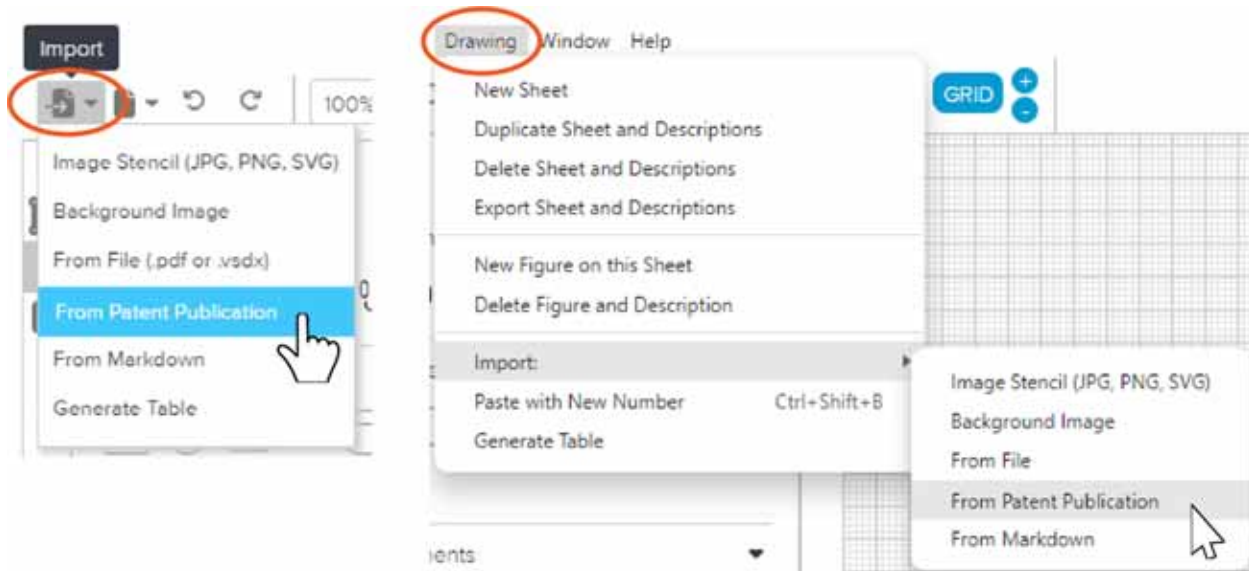

3. Enter identifying numbers for the publications you wish to select figures from and click the Search button.



4. Select the pages you wish to import from the dialog provided by clicking Select All, Deselect All, and the individual page thumbnails as needed.

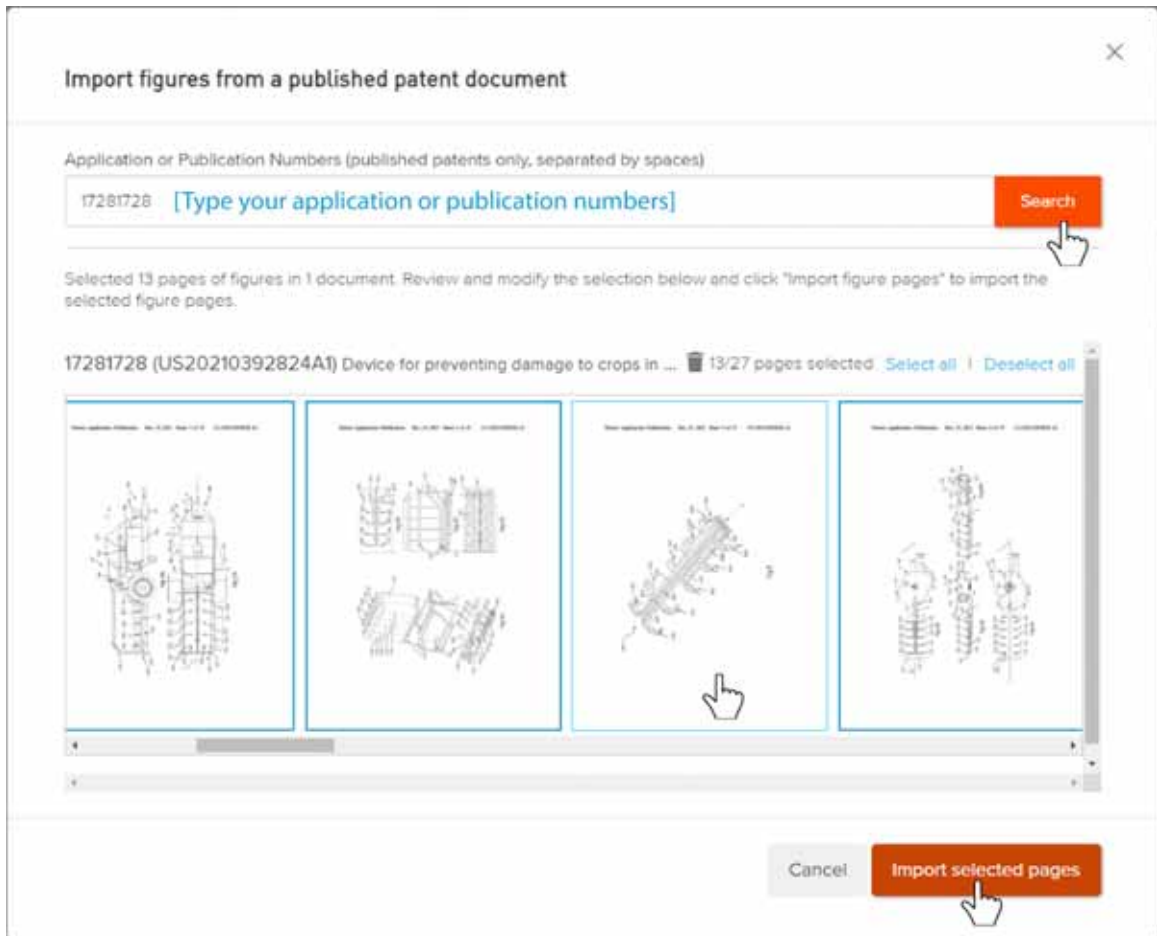

*We will attempt to detect all pages containing figures and drawings rather than numerous text paragraphs, and our results will be selected by default.*

5. Click the Import selected pages button.
6. Each selected page will be populated as a background image on a new figure sheet.

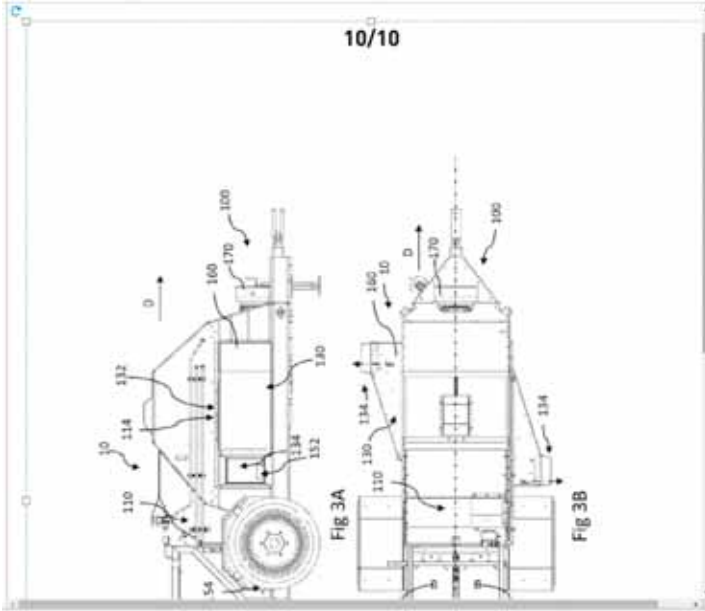

7. Crop out or cover any elements you do not wish to be shown, as needed. Group elements and lock elements to the canvas as needed.

## Add a Figure from Markdown Code

1. In the Drawing Tool, select the From Markdown option from the Import control dropdown in the toolbar or under the Drawing menu.

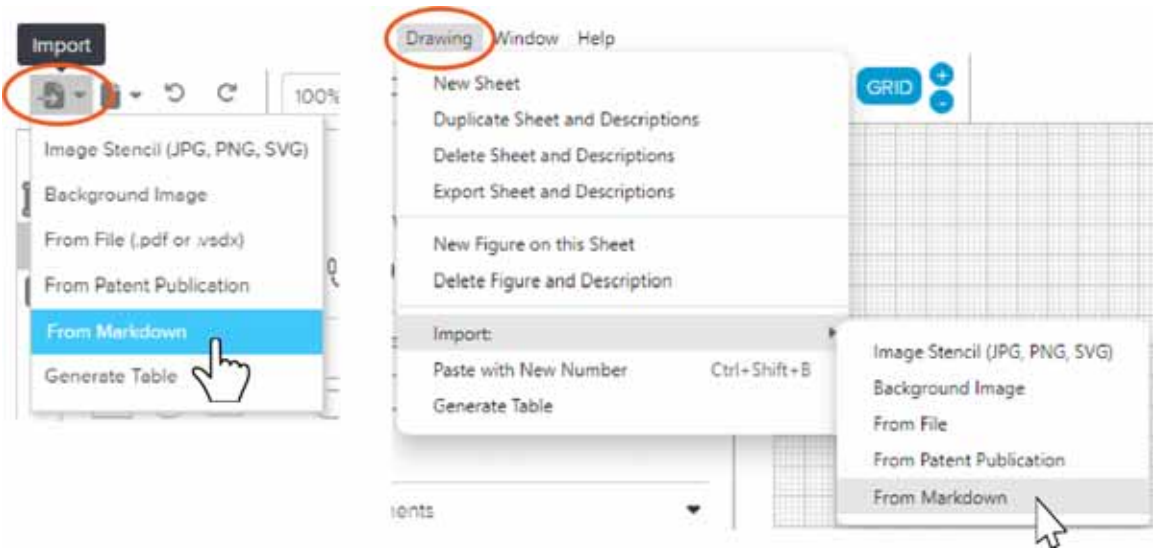



2. When prompted, select the text (.txt) file containing your script.

```
sequenceDiagram
ActorA->ActorB: Solid line without arrow
ActorB-->ActorA: Dotted line without arrow
ActorA->>ActorB: Solid line with arrowhead
ActorB-->>ActorA: Dotted line with arrowhead
ActorA->ActorC: cross
%% this is a comment
note right of ActorA: note
```

The script Rowan Patents uses is based on Mermaid Markdown. For more information, see <https://en.wikipedia.org/wiki/Markdown>.

3. A sequence diagram based on your .txt script will be created as a new figure.

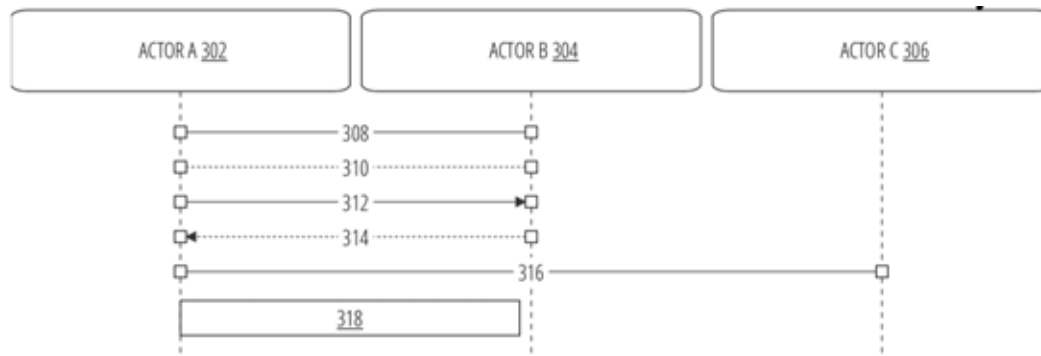

## Add a New Figure

### Add a New Sheet and Figure

1. Open the Drawing Tool.
2. Click the New Sheet option from the Sheets and Figures dropdown in the toolbar

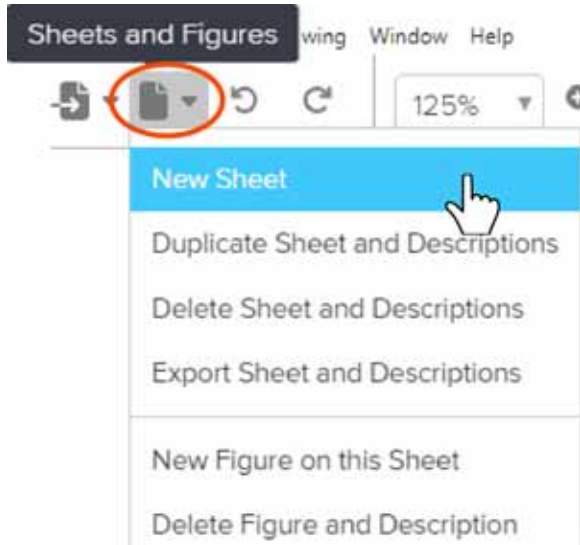

OR click the New Sheet option under the Drawing menu

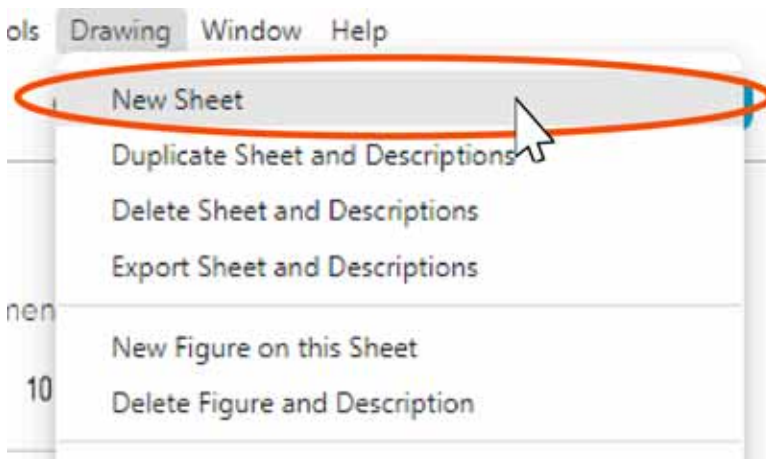

3. A new, empty sheet, with sheet numbering and a FIG. # label will be added at the end of your figure set.

## Add through Sheet Duplication

1. Open the Drawing Tool.
2. Navigate to the figure sheet you wish to duplicate.
3. Click the Duplicate Sheet and Descriptions option under the menus at the top of the Sheets panel and the the right of each thumbnail in the Sheets panel, the

Sheets and Figures dropdown in the toolbar, or under the Drawings menu.

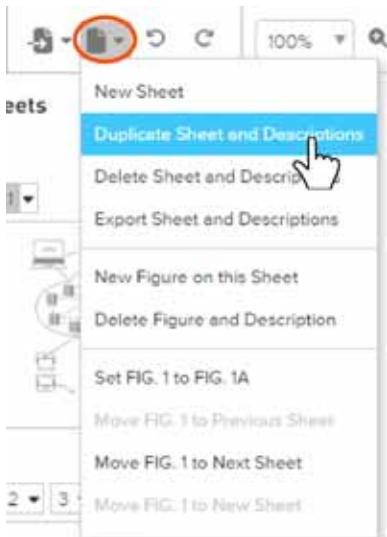
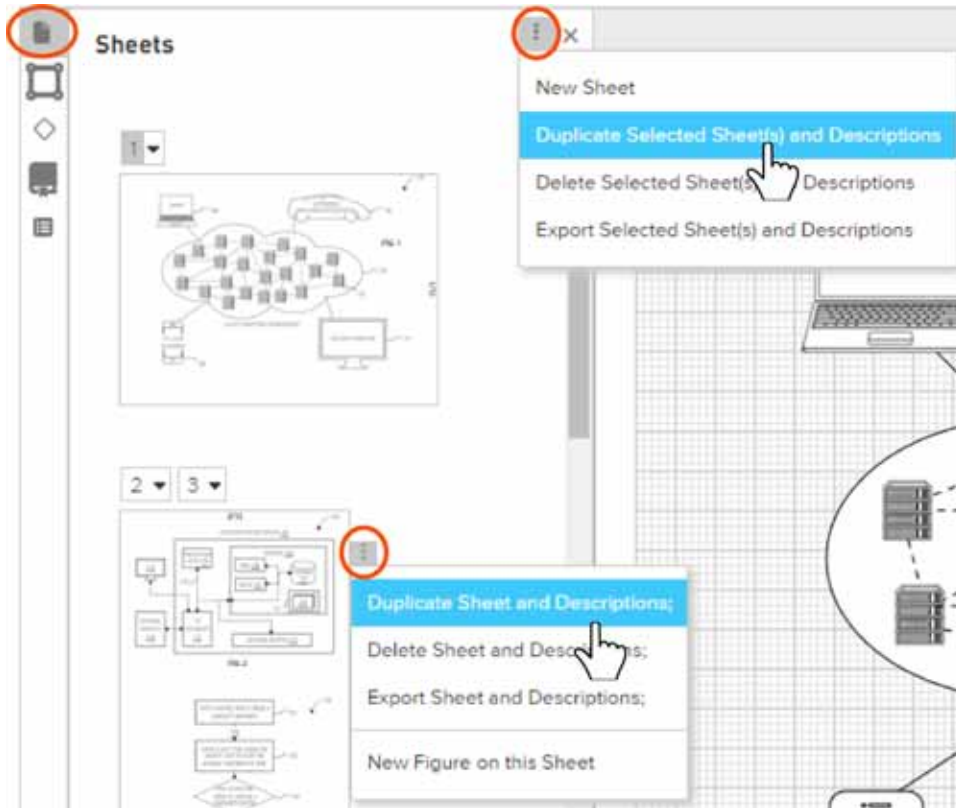

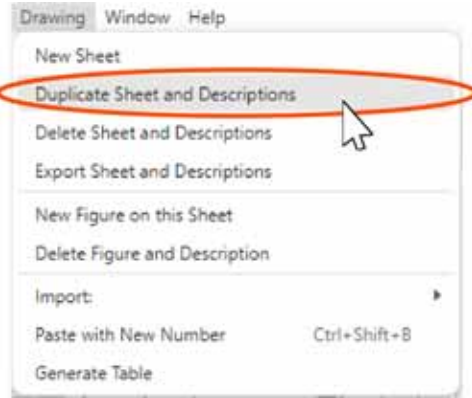

4. A new figure sheet and new description sections will be populated at the end of your figure set with duplicated data.

## Add a New Figure on an Existing Sheet

1. Open the Drawing Tool.
2. Navigate to the desired figure sheet.
3. Click the New Figure on this Sheet option in the menu available to the right of a selected sheet thumbnail, the Sheets and Figures menu in the tool bar, or the Drawing menu.

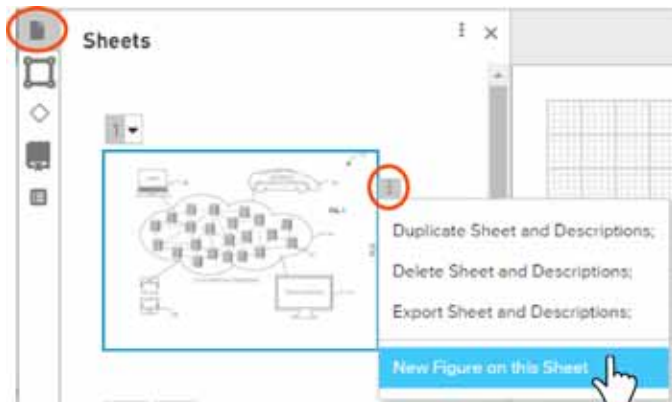

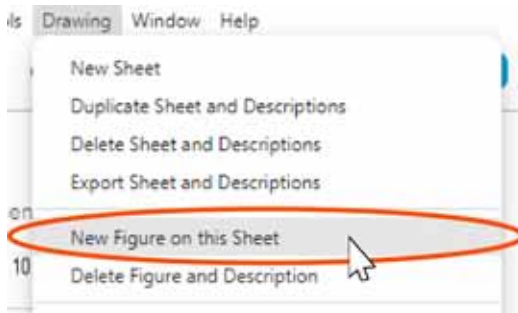
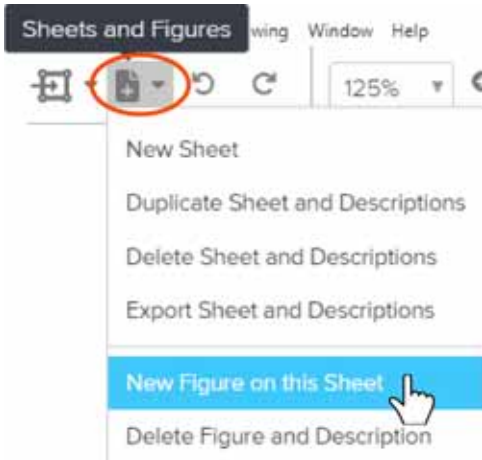

OR drag the FIG stencil from the Special elements stencil menu onto the drawing canvas.

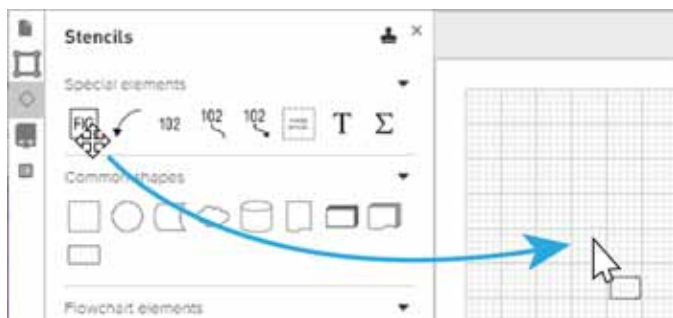

4. A FIG. # label will be added to your current sheet and can be clicked and dragged or moved with your keyboard arrow keys to your desired location.

*Note that to allow each figure to be manipulated independently, an unselected figure sharing a sheet will be grayed out and disabled to prevent accidental modifications.*

## Add a New Figure and its Figure Description Sections in the Specification

1. Open your application.
2. Navigate to the brief or detailed figure description sections and locate the point at which you wish to add a figure.
3. Hover where you wish to add your figure to reveal the Add figure controls.

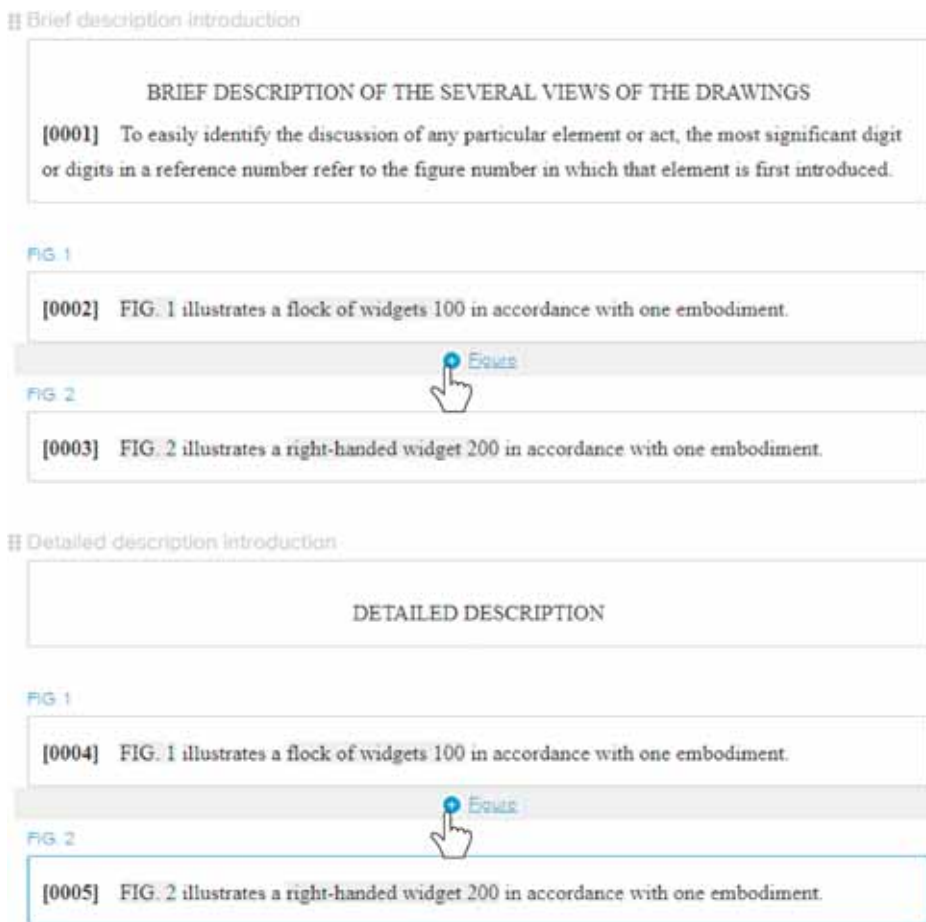

*Note that before the first figure description and after the last, where adding a non-figure section is also allowed, Add figure and Add section controls are both available in the hover bar.*

☰ Detailed description introduction



4. Click the Add figure option.
5. New brief and detailed figure description sections will be added at the selected points of the specification. A new figure sheet will also be added in the Drawing Tool.

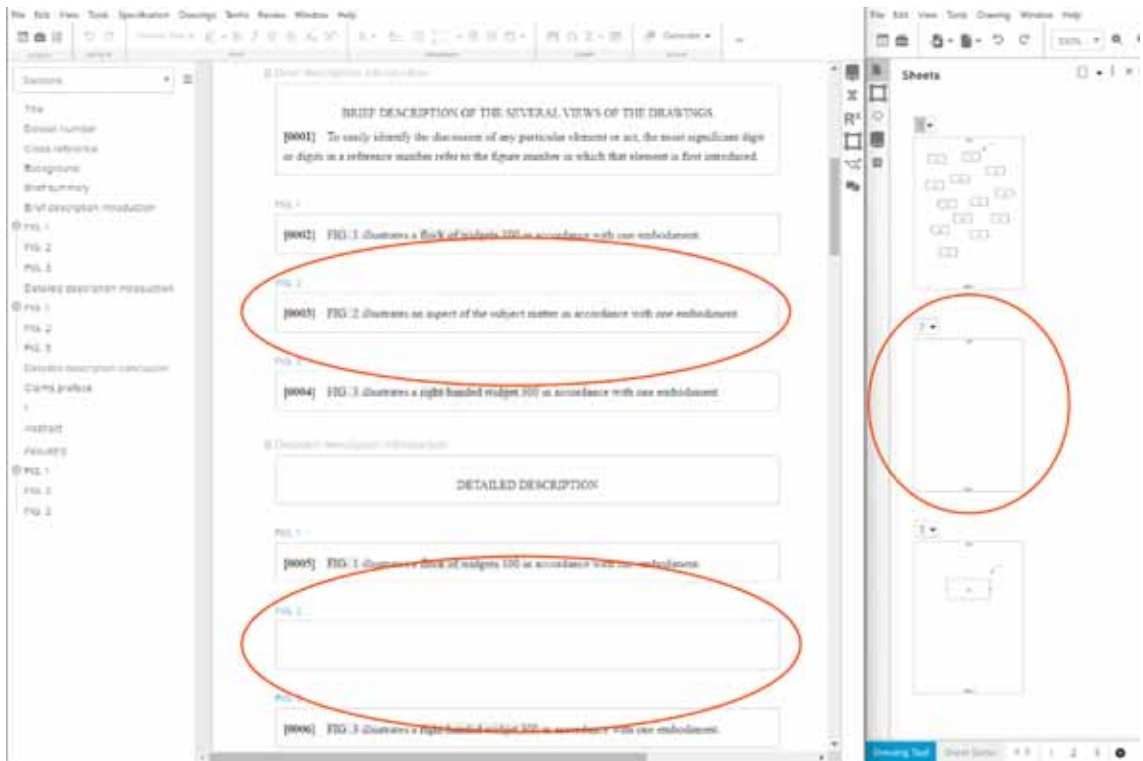

# Import a Background Image

1. Open the Drawing Tool and create or navigate to a desired figure.
2. Copy your image file in your local file system and paste it onto the drawing canvas

OR select the Background Image option under the Import dropdown control in the toolbar or under the Drawing menu

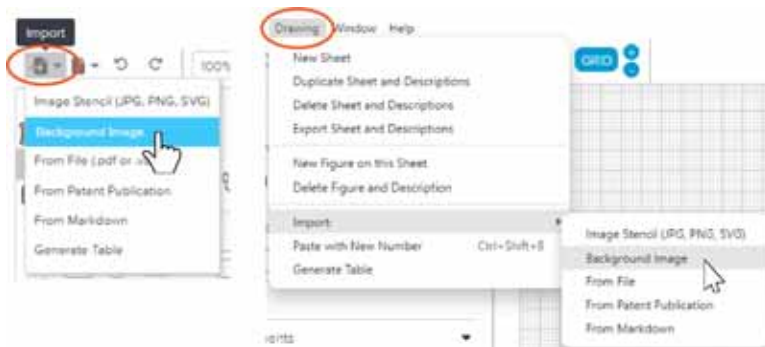

3. Drag and drop your desired image onto the target area of the presented dialog

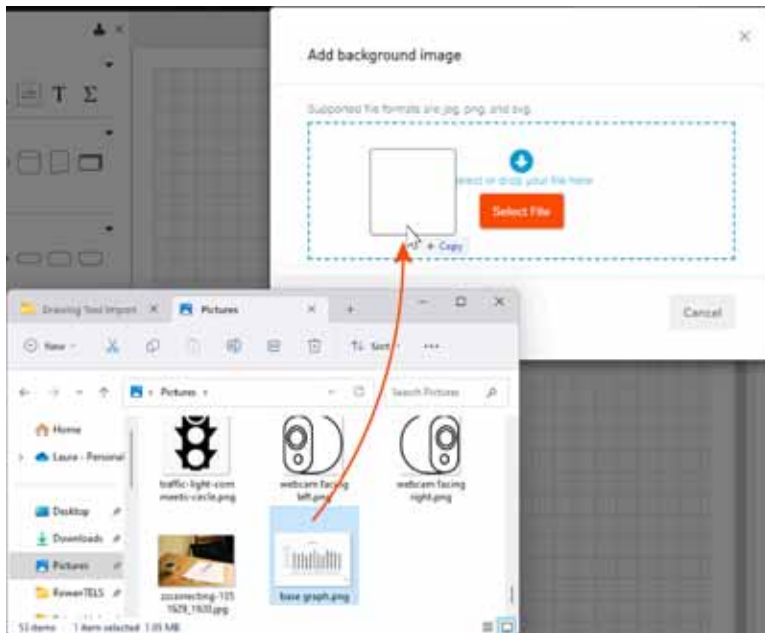

OR click Select File to browse to your image in your local file system.



- Your image will be inserted as an un-numbered object within your figure.

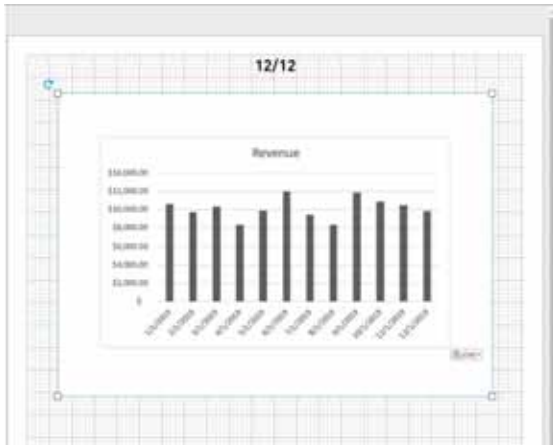

*Your background image can be cropped, locked to the canvas, and numbered quickly using number stencils and the Stamp Stencil control.*

## Crop Imported Image

- Select the image you've imported.
- Click the Crop control provided in Transform menus in the toolbar and the right-hand sidebar.

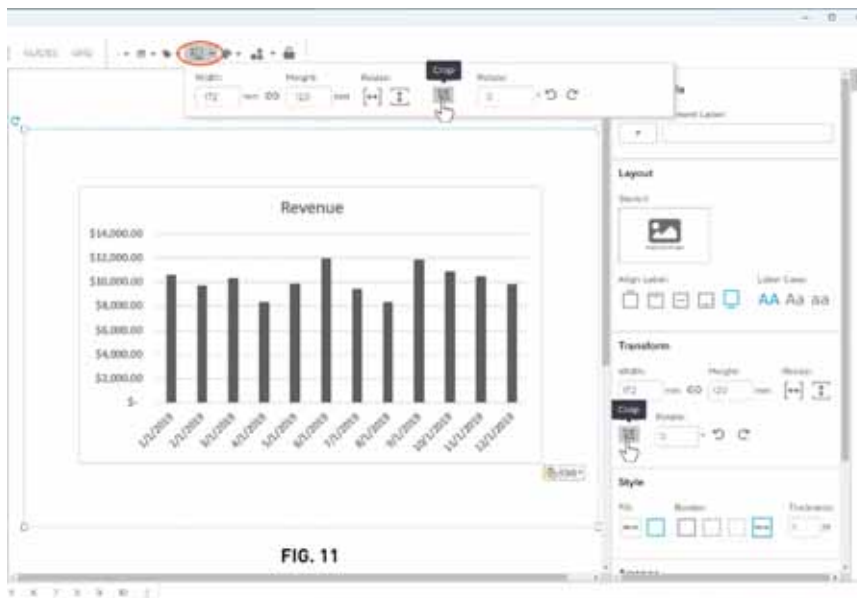

- Use the handles provided in the Crop Image dialog to make the desired adjustments and click okay.



- The cropped image will appear on the canvas. Further adjustments can be made by clicking the Crop control again if needed.

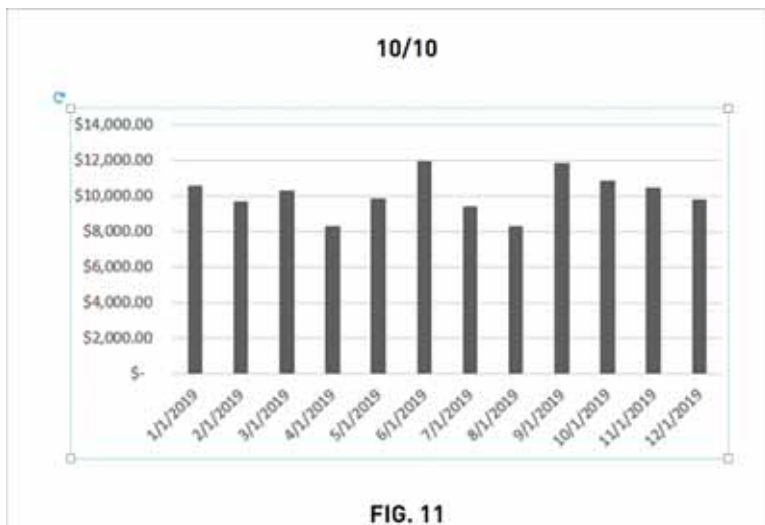
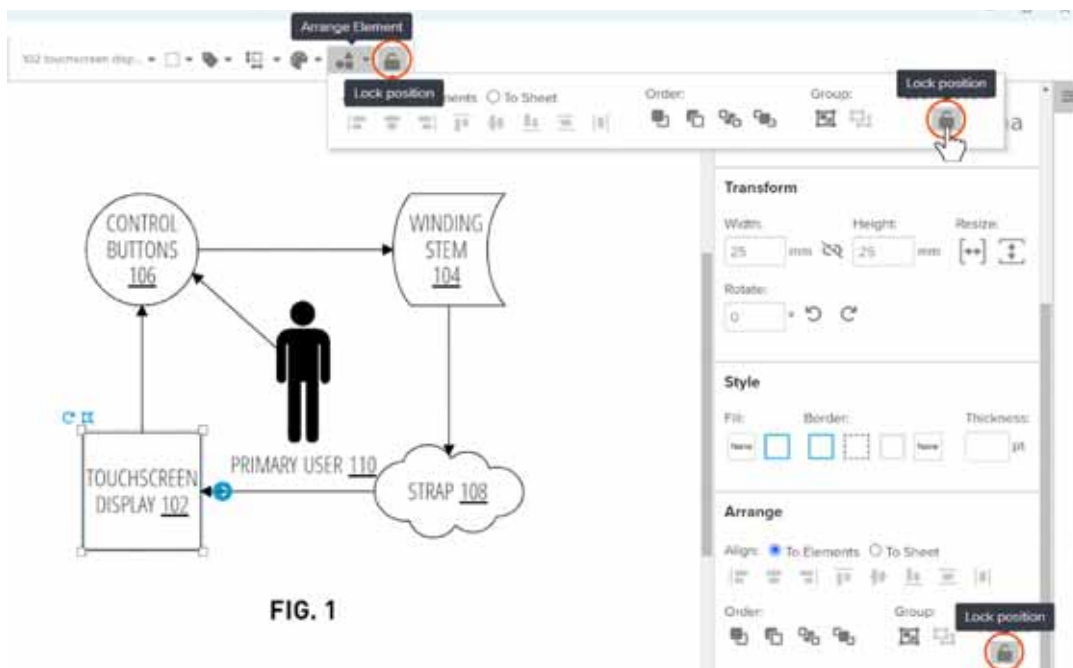

FIG. 11

# Lock Elements to the Drawing Canvas

1. Select the element(s) you wish to lock to the drawing canvas.
2. If needed, reposition the elements to the location you desire.
3. Locate and click the Lock Position control under the toolbar Arrange menu, in the toolbar itself, or in right-hand sidebar.



4. To unlock locked elements, select locked elements and re-click this control.

# Stamp Identical Stencils

1. Select the Stamp Stencil control in the Drawing Tool left-hand Stencils panel.

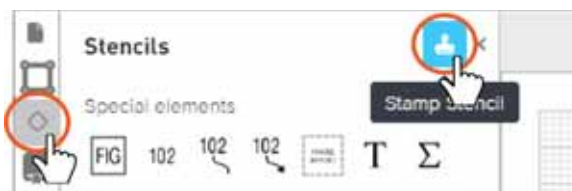

2. Select the desired stencil.



3. Click the drawing canvas to stamp as many of these stencils as you need.

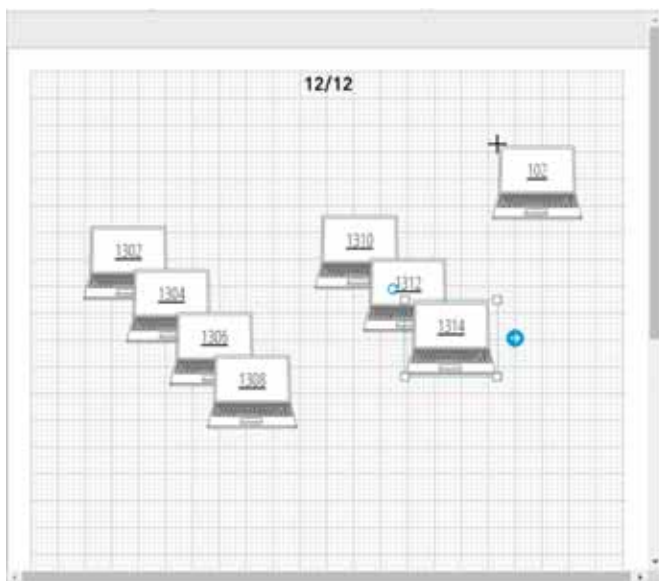

*Note that a stencil just placed is selected (indicated by visible control points and a dotted blue boundary outline). Its border style, number position, label alignment, and label case attributes can be changed at this time, and the new settings will be applied to subsequently stamped stencils.*

4. Select a different stencil in the left-hand Stencils panel to continue stamping copies of a different shape.

*Note that a currently-selected stencil's shape can be changed with the edit stencil shape control, but this setting will not be applied to subsequent stamps.*

5. Click the Stamp Stencil control again OR press Esc on your keyboard to exit

stencil stamping.

## Rotate Drawing Sheet Orientation

### Rotate a Single Sheet

1. Navigate to the figure drawing sheet you wish to rotate orientation for.
2. Click the orientation control in the toolbar to apply the option shown in the tooltip



OR

Click the orientation control dropdown to apply a different available option.

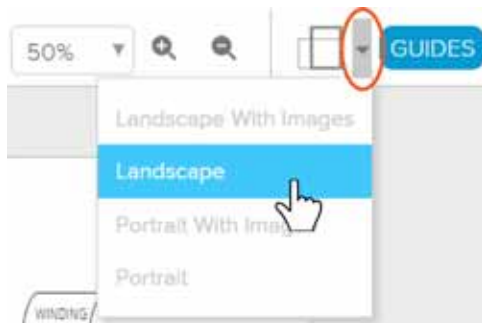

*Note that only options applicable to your selected sheet will be available. See more below on rotating images with sheets.*

3. Sheet orientation will be updated based on your selection.

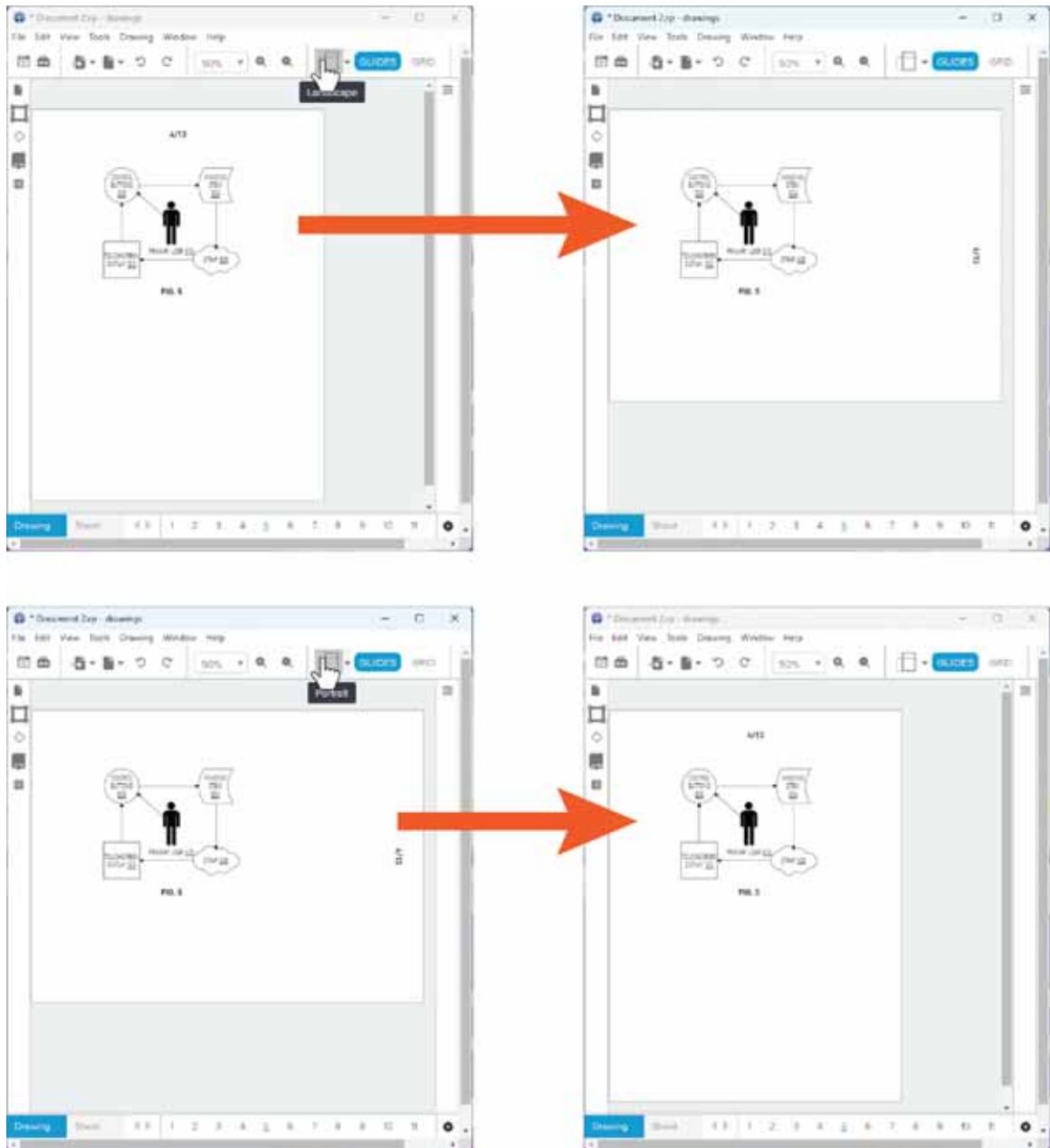

## Rotate Multiple Sheets

1. Open the Sheets panel in the left-hand sidebar of the Drawing Tool.
2. Scroll as needed to locate the sheet(s) you wish to rotate.

3. Click, Ctrl+Click (Cmd-Click for Macs), or Shift+Click to select the sheet(s) you wish to rotate.

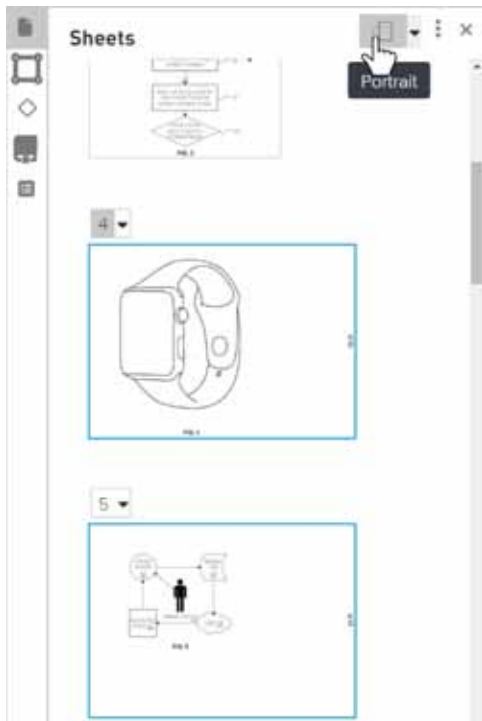

4. Click the rotate orientation control at the top of the Sheets panel to apply the option shown in the tooltip



OR

Click the orientation control dropdown to apply a different available option.



*Note that the clicked option will only change orientation where applicable. For example, the "Portrait" option is available with a mix of portrait- and landscape-oriented sheets selected, but clicking it will only cause changes to landscape-oriented sheets.*

5. Your sheets will be rotated according to your selection.

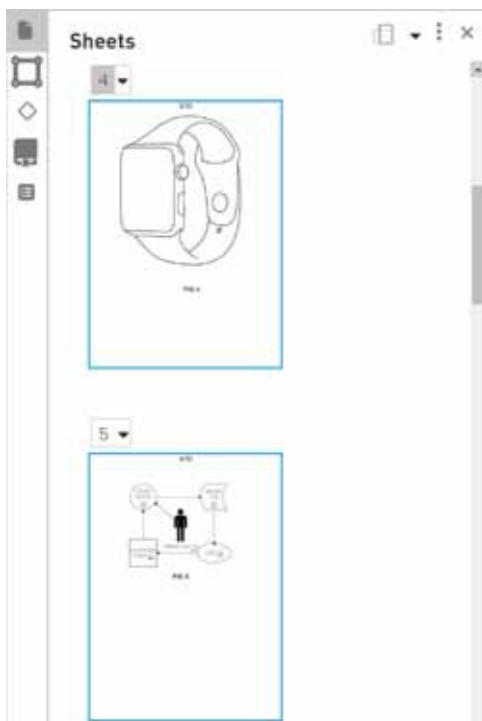

## Rotate Background Images with Sheets

1. Navigate to/select the desired sheet(s) as described above.



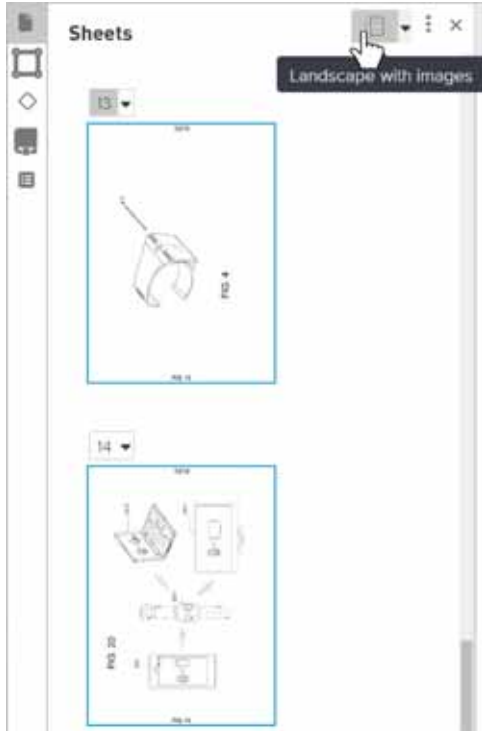

2. Click the rotation control at the top of the Sheets panel when the "with Images" tooltip is displayed

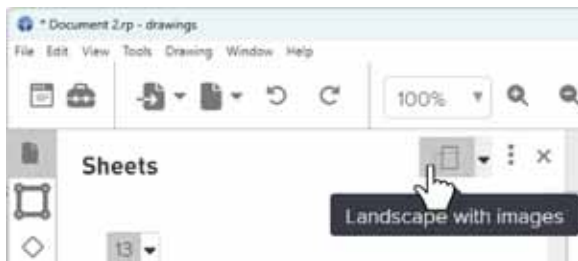

OR

select the dropdown menu option that includes "with Images".

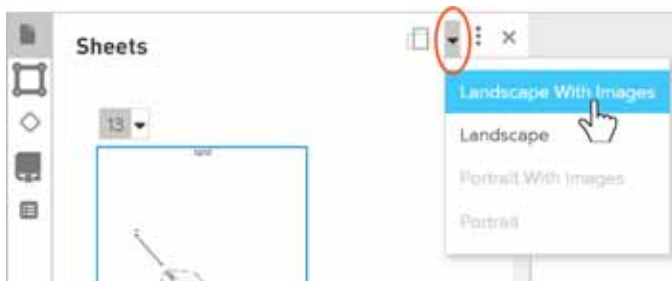

*Note that the "with Images" options will only be available when the selected sheet(s) include a background image.*

3. The background image will rotate along with the changed page orientation.

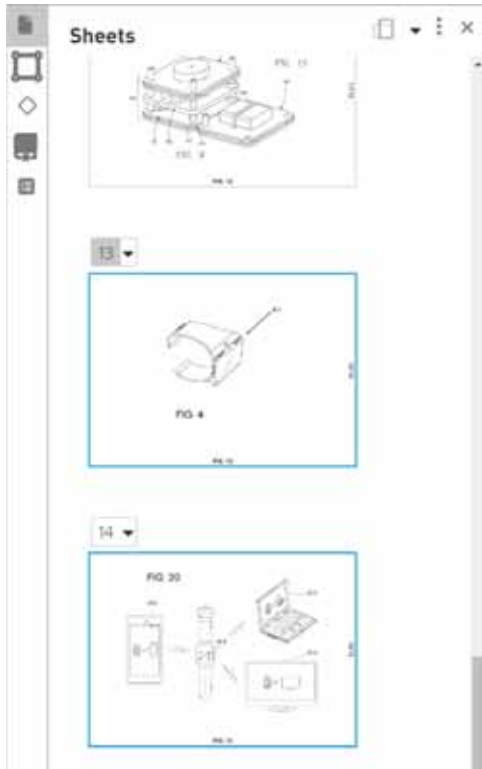

*Note that this rotation will only be applied to images imported as background images. Image stencils and other stencils will not rotate.*

## Adjust Drawing Canvas Zoom

1. To zoom IN on just the drawing canvas, select the desired higher zoom level from the dropdown or click the Zoom In icon (a magnifying glass with a plus sign) in the Drawing Tool toolbar



OR

Press Ctrl+= (Cmd-= for Macs) on your keyboard

OR

Press Ctrl (Cmd for macs) and use your mouse's scroll wheel.

2. To zoom OUT on just the drawing canvas, select the desired lower zoom level from the dropdown or click the Zoom Out icon (a magnifying glass with a minus sign) in the Drawing Tool toolbar.

OR

Press Ctrl+- (Cmd-- for Macs) on your keyboard

OR

Press Ctrl (Cmd for macs) and use your mouse's scroll wheel.

3. To return to ACTUAL SIZE on just the drawing canvas, select the 100% zoom level from the dropdown in the Drawing Tool toolbar

OR

Press Ctrl+0 (Cmd-0 for Macs) on your keyboard.

*Note that you can also zoom the entire Drawing Tool window in and out.*

## Use and Adjust Canvas Grid and Guides

1. Click the Grid button in the Drawing Tool toolbar to turn the canvas grid on or off.

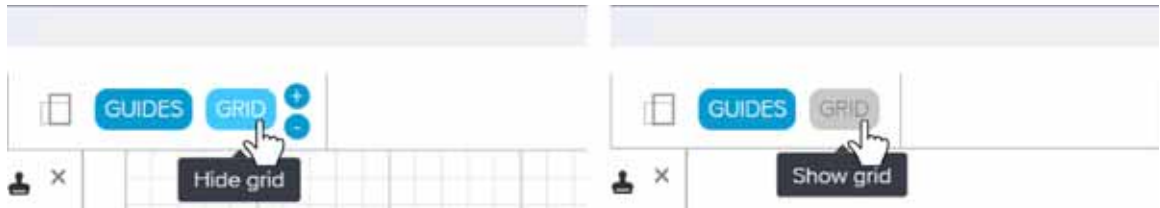

*Note that element placement and sizing adjustments are performed based on grid increments. Turning the grid off provides the most granular control.*

2. Click the + and - controls to the right of the Grid button to increase or decrease grid size, respectively.



*Note that a larger grid size will make consistent sizing and alignment easier, but reduces the granularity of control, which is improved at smaller grid sizes.*

3. Click the Guides button in the toolbar to turn alignment guides on and off.



Alignment guides can help you drag and drop stencils into alignment quickly, but can also reduce the granularity of placement control, especially in figures populated with a large number of elements.

## Subnumber Figures

### Include Figures in a Subnumbered Set

1. Open the drawing tool and navigate to or create the desired figure.
2. The figure label (FIG. #) should be selected upon arriving at the figure, but click it to select it if needed.
3. Use the Sheets panel menu above the thumbnail for the desired sheet, the Sheets and Figures dropdown menu, OR the Figure Info options in the toolbar or the right-hand sidebar to apply figure subnumbering.

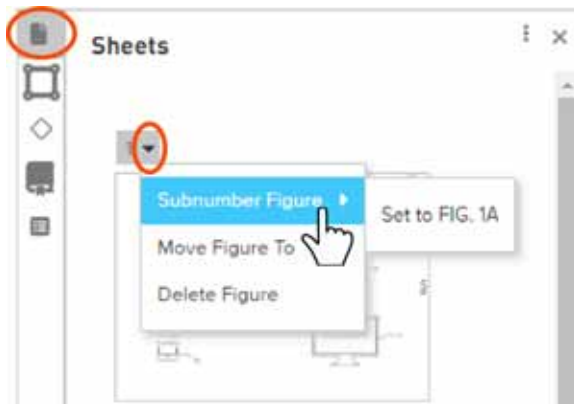

4. If your selection means a new figure needs to be created, select whether you want that figure created on the current sheet or a new sheet.

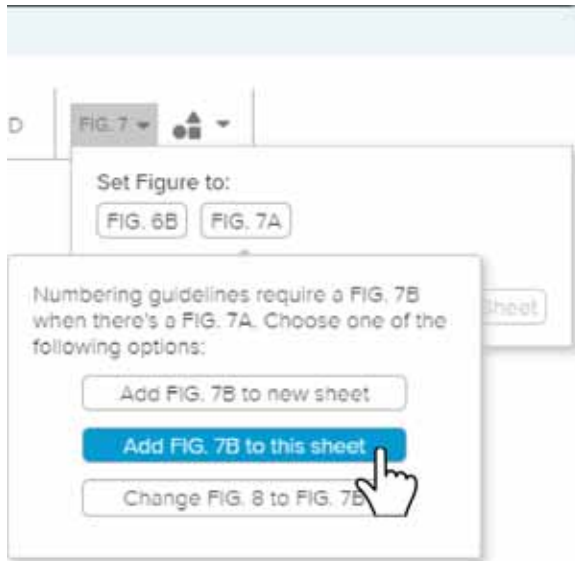

5. For new figures added to the current sheet, the additional figure label will appear in the center of the sheet, unselected, and can be clicked and dragged where desired.



*Note that to allow each figure to be manipulated independently, an unselected figure sharing a sheet will be grayed out and disabled to prevent accidental modifications.*

*Clicking the figure label or any element of the unselected and grayed-out figure will bring focus to that figure.*

## Remove Figures from a Subnumbered Set

1. Navigate to the last figure in the subnumbered set.
2. The figure label (FIG. #) should be selected upon arriving at the figure, click it to select it if needed.
3. Use the Sheets panel menu above the thumbnail for the desired sheet, the Figure Info options in the toolbar, OR the right-hand sidebar to remove figure subnumbering.

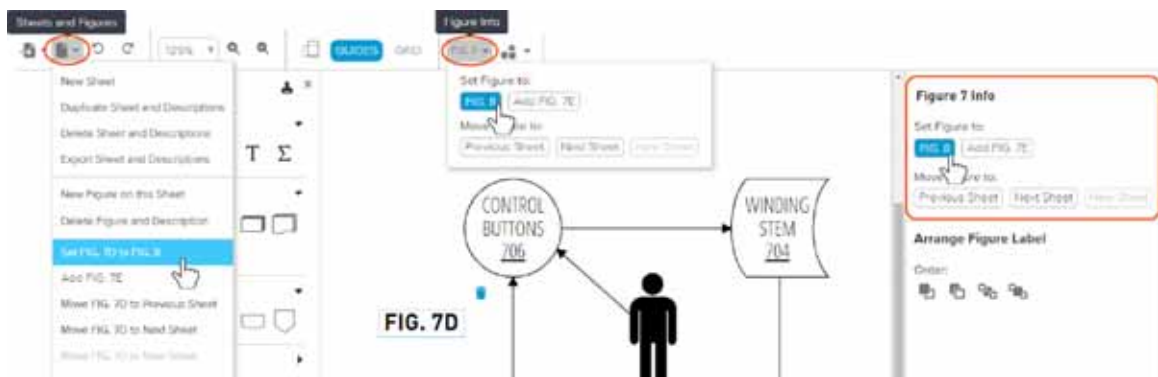

4. Repeat these steps as needed.

*Note that some options will not be available for figures within a figure set. To remove or reorder a single figure from the middle of a set, undo subnumbering from the last figure forward, move the figure out of the set to the desired location, and re-subnumber the desired figures following the process above.*

*Note also that where multiple figures share a sheet, some may need to be moved*

*to other sheets so that each is on its own sheet before they can be reordered or removed from a set.*

## Reorder Figure Sheets

### Reordering One or More Sheets in the Sheets Panel

1. Open the Sheets panel in the left-hand sidebar of the Drawing Tool.
2. Scroll as needed to locate the sheet(s) you wish to reorder.
3. Click, Ctrl+Click (Cmd-Click for Macs), or Shift+Click to select the sheet(s) you wish to reorder.
4. Click the drag handle to the left of a selected sheet.
5. Drag the sheet(s) to the desired insertion point between thumbnails displayed in the Sheets panel.
6. With the insertion bar visible, release the mouse button to drop the sheet(s) in the new location.





*Note that descriptive sections in the specification will also be reordered to reflect this change. Note also that, for autonumbered figures, part reference numerals will be automatically updated in the figure(s) and across the specification and claims.*

## Simple Sheet Reordering in the Sheet Sorter

1. Open the Drawing Tool and click the Sheet Sorter option to the lower-left.



2. Click a figure sheet thumbnail and drag it to the position you want to place it in.

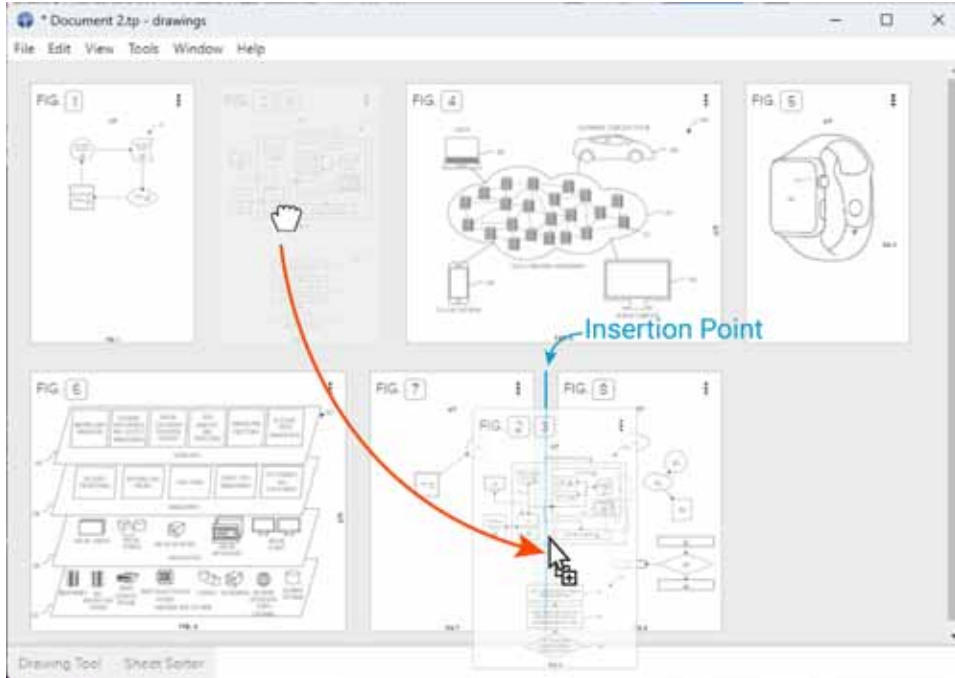

*A blue insertion point indicator will appear to show where your figure sheet will be placed upon drop.*

3. Drop your figure sheet into its new location. Brief and detailed description sections in the specification will be automatically reordered to reflect your changes.

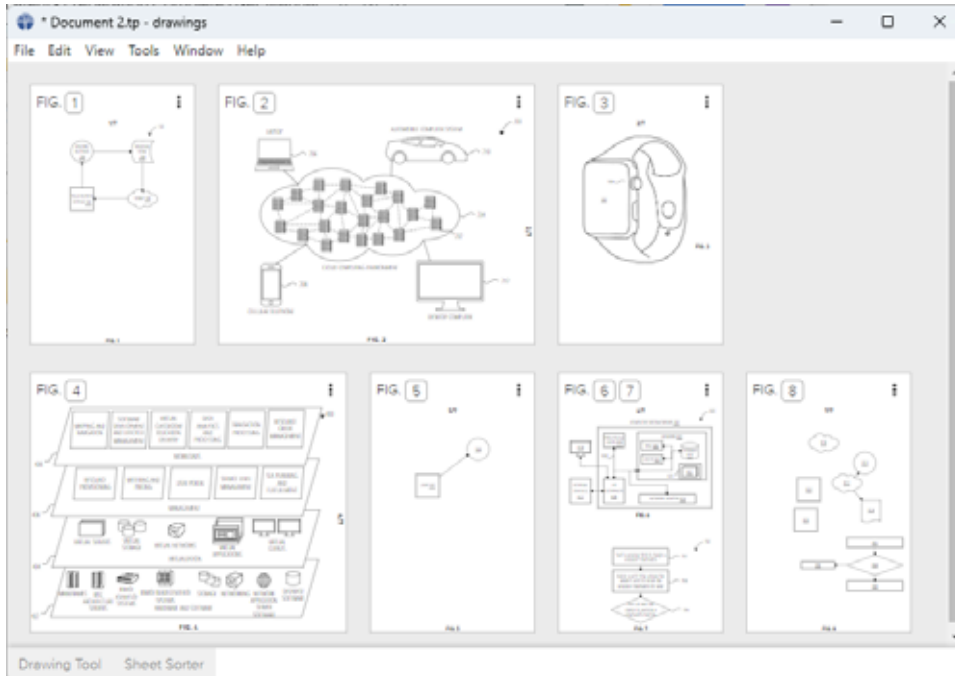

*Note that where sheets contain multiple figures, they must all be moved together.*

## Reordering Sheets with Subnumbered Figures

1. Navigate to the last figure in the subnumbered set.

*Where multiple sheets display a set of subnumbered figures having the same number and distinguished by an alphabetic suffix, e.g., FIG. 1A, FIG. 1B, and FIG. 1C, those sheets must be moved together.*

2. Starting with that last figure and working forward, remove subnumbering for all figures you wish to reorder.

*For example, if you have FIGs. 1A-1F, and you only wish to swap FIGs. 1D and 1E, you will need to remove subnumbering from FIGs. 1F, then 1E, then 1D.*

3. Reorder the individual sheets and figures as desired, as described above.
4. Reapply subnumbering to the figures if desired.

# Move Figures to Other Sheets

1. Navigate to the desired existing figure.
2. The figure label (FIG. #) should be selected upon arriving at the figure, but click it to select it if needed.
3. Click the desired Move Figure to option under the menu available above a thumbnail in the Sheets panel or the Figure Info controls in either the toolbar or the right-hand sidebar to relocate the figure to a different sheet.

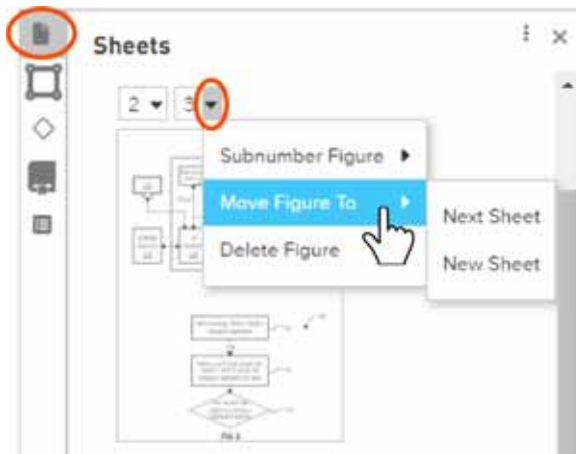

*If an option is grayed out, it is not available based on the selected figure's order in a subnumbered figure set and/or on its current sheet.*

4. The figure will be moved to a previous, next, or new sheet as selected.

*Note that the figure will appear in the same location on its new sheet as on its earlier sheet. As a best practice, check the desired target sheet in advance and move existing elements to a location that will not conflict with the moved figure.*

## Export Drawing Sheet(s) as a New .rp File

1. Navigate to the drawing sheet(s) you wish to export to a standalone .rp file.
2. Select the Export Sheet and Descriptions option in the Sheets panel menus, under the Sheets and Figures dropdown in the toolbar, OR the Drawing menu at the top of the Drawing Tool.

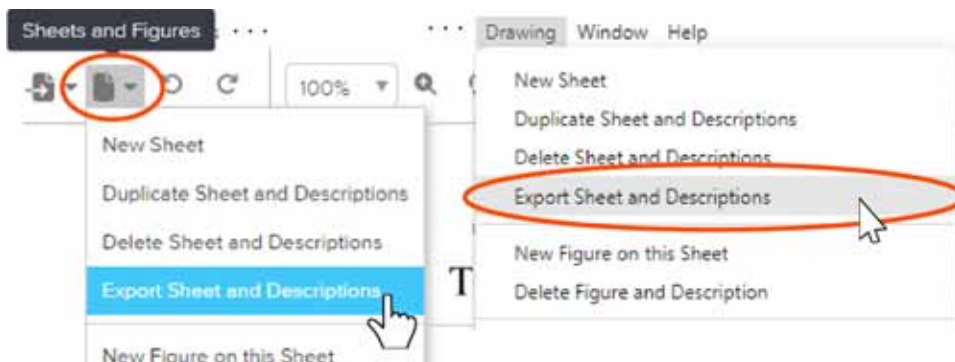
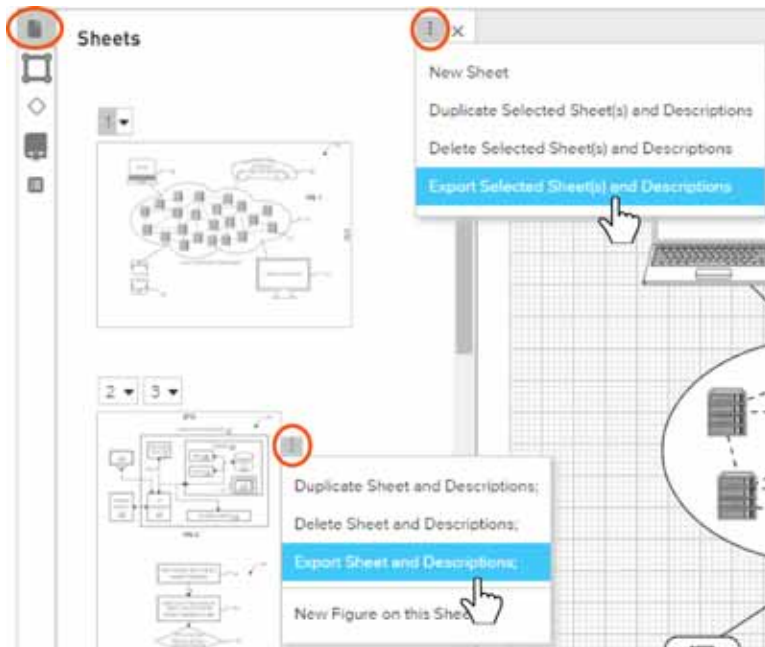

3. Use your operating system's save dialog to save your new .rp file containing your sheet with its figure(s) and its associated description(s).

*This figure(s) can now be easily included in other .rp files.*

*Note that all figures on the sheet will be exported. If you only want one of the figures on a multi-figure sheet, you will need to move the one(s) you don't want to export to a different sheet.*

## Delete a Figure or Sheet

*Note that deleting a figure will also delete the corresponding sections in the specification. If you wish to delete a figure but keep its descriptive text, take steps to preserve that text before deleting the figure.*

### Simple Delete Operation

1. Open the drawing tool and navigate to the figure you wish to delete.
2. Click the FIG. # label for that figure.
3. Click the trashbin icon to the upper-right of the FIG. # label.

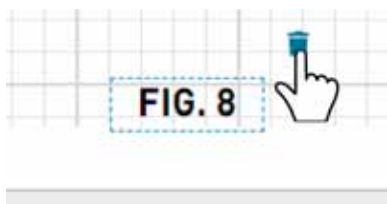

4. A confirmation dialog is presented, as this operation deletes the description section as well as the figure, and cannot be undone.
5. Click the Delete Figure and Description button.

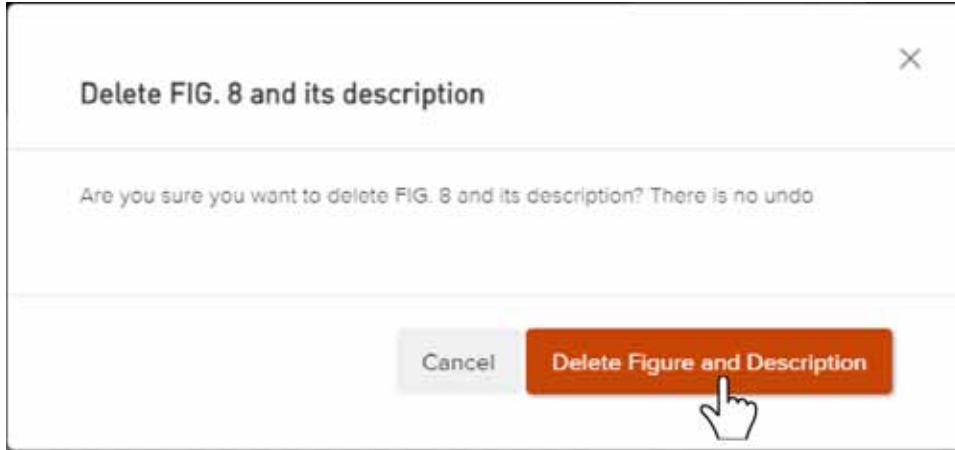

- The figure and its specification sections will be removed. All figure and part renumbering will be performed automatically throughout your entire application.

## Other Ways to Delete Figures

One or more figures/sheets can be selected in the Sheets panel and deleted individually or altogether.

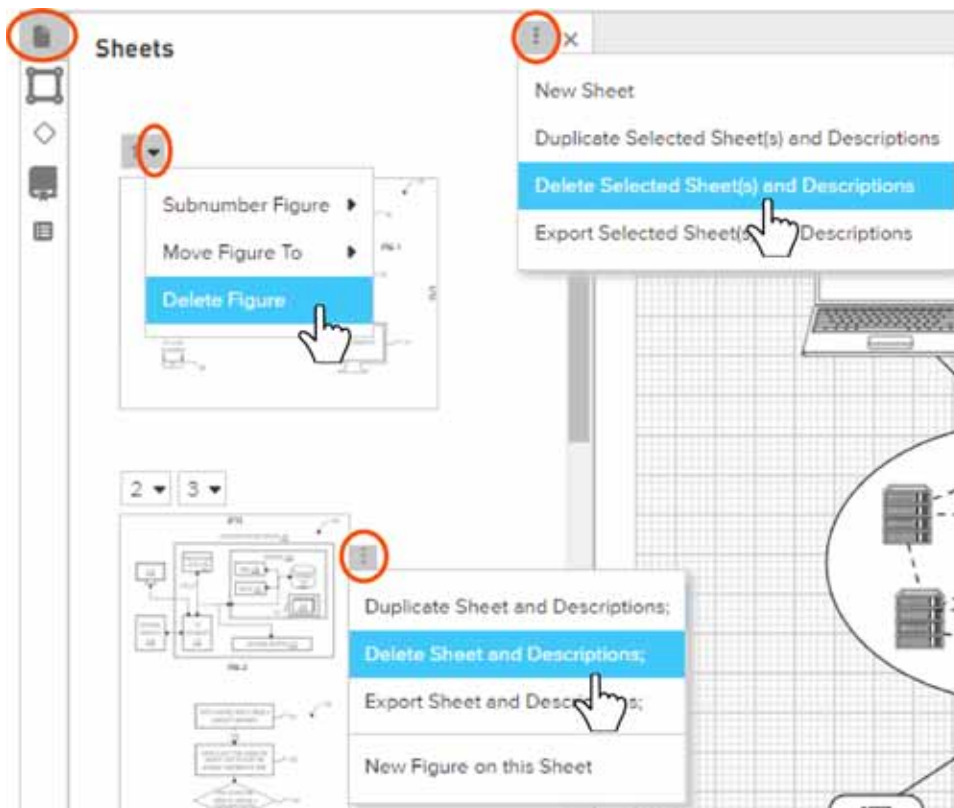

A figure in focus on the drawing canvas or an entire displayed drawing sheet can be deleted from the Sheets and Figures dropdown in the toolbar or the Drawing menu.

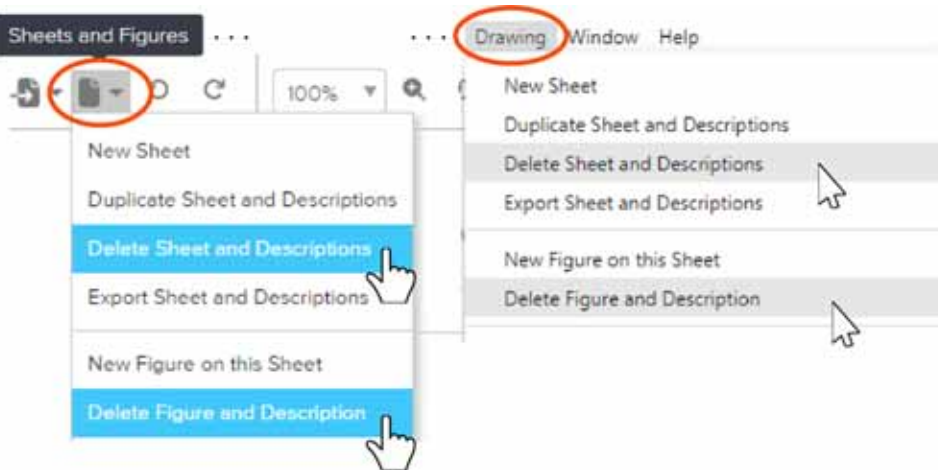

Figures can also be deleted while in the sheet sorter view.

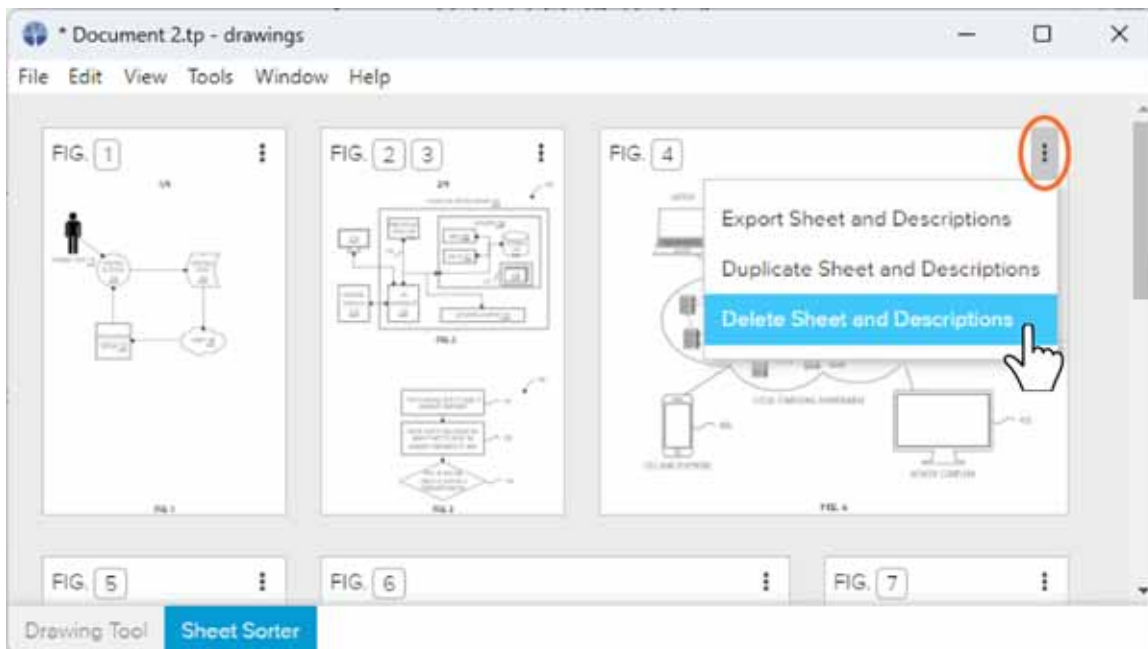

*Note that deleting a sheet may delete multiple figures. In this case, the confirmation dialog will list the figures you're potentially deleting along with their specification*



sections.

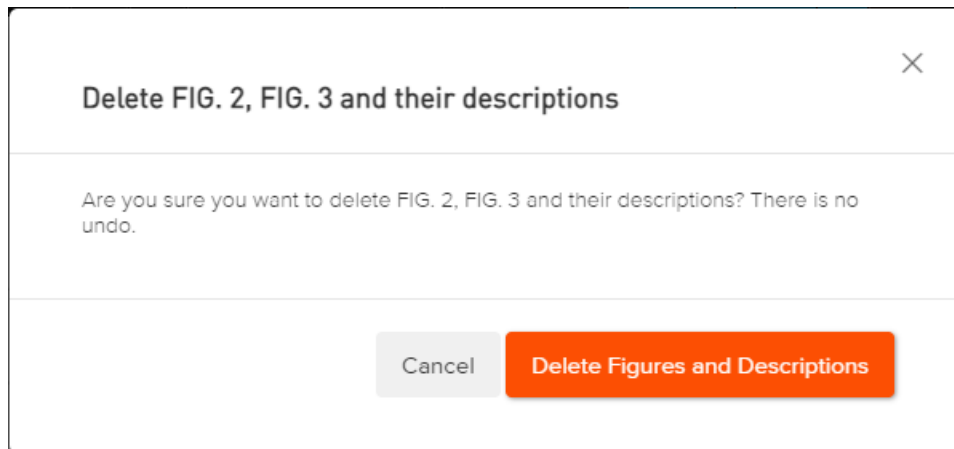

## Create New Parts

### Create New Parts in the Parts Panel

1. Open the Drawing Tool and expand the Parts Panel in the left-hand sidebar.

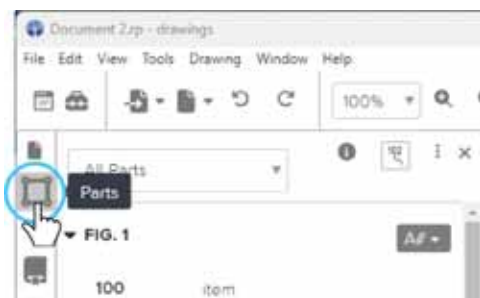

2. Navigate to the figure you wish the part(s) to be associated with  
OR click a part listed for that figure in the Parts Panel.
3. Click the Add Part control provided at the end of each figure list  
OR place your cursor at the end of a part name and press Enter on your keyboard.

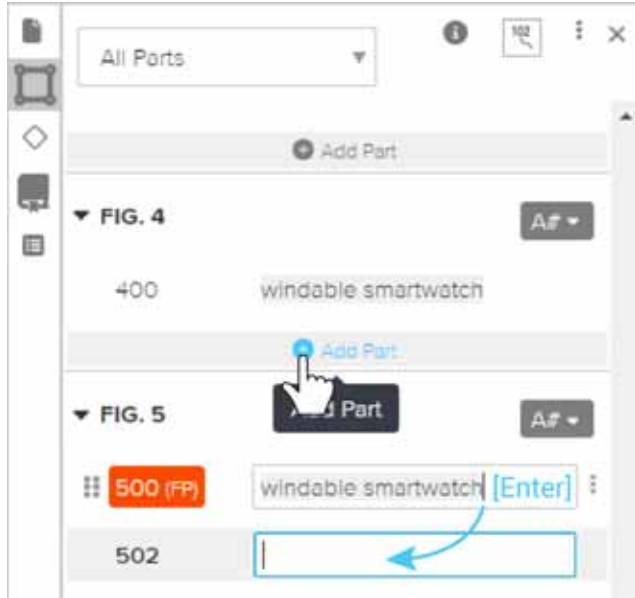

4. Provide the desired part data (number and name) for your part.
5. Hit enter after typing the part name to quickly create another part in your current figure list and repeat this process.

*For autonumbered figure lists, changes made to the increment will be “sticky” when new parts are created but can be quickly modified as desired by clicking the part number control and making a new selection.*

## Other Ways New Parts Are Created

New parts are created and populated in the Parts Panel list in a few other ways:

- Placing a stencil on the canvas creates a new part.
- Placing a term on the canvas creates a new stencil and a new part.
- Importing Word (.docx) text identifying part references creates a parts list to hold detected part numbers and names.

*Note that removing the number from or deleting a stencil from the canvas may not remove the part from the Parts Panel. Parts must be deleted in the Parts Panel, or will be deleted when their associated figure is deleted.*

# Select Autonumbering Mode for Parts

## Autonumbering Mode Overview

Autonumbering mode maintains all of the functionality of the previous numbering scheme but with a greater level of flexibility. Numbers still default to a “by 2” (x2) increment, but now you can change that to other increments: x1, x4, x5, and x10. When reordering, the numbers will maintain the set multiple for that part. For instance, you can set a number to x10 to always maintain the part number ending in 0 even when it is moved around to different locations in the parts list.

We believe this mode will address a majority of the workflows that users have described to us. However, if not, that’s why we added a Manual numbering mode.

## Select Autonumbering for One Figure List

1. Open the Drawing Tool and expand the Parts Panel in the left-hand sidebar.



2. Click the Part Numbering Mode control in the upper-right corner of the desired figure parts list.

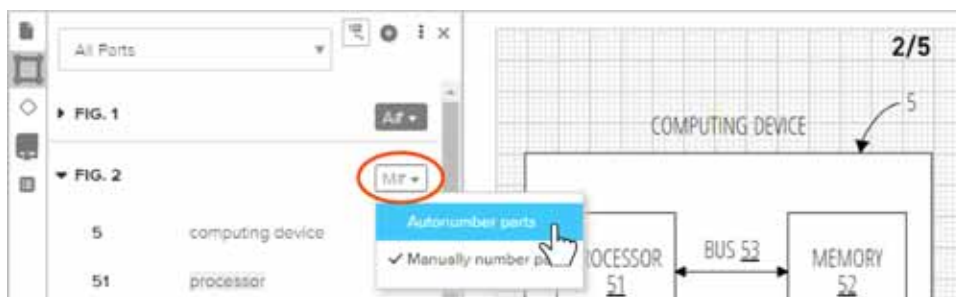

*Note that parts are collected into lists for each figure and that the numbering mode will be applied to the entire figure list.*

3. Select the Autonumber parts option for the figure list.
4. Confirm your selection in the dialog presented.

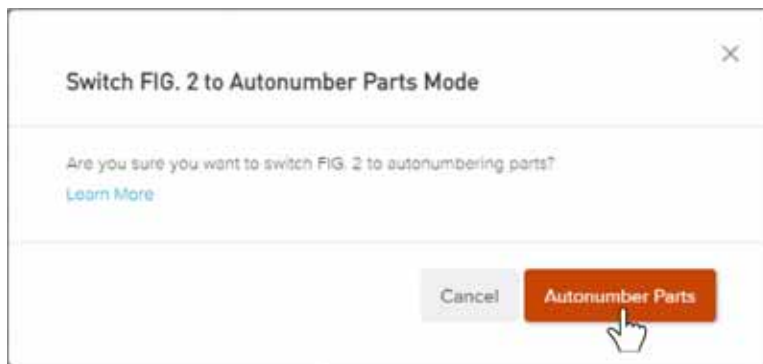

5. The parts in that figure list will be autonumbered by Rowan based on the figure number and parts list location.

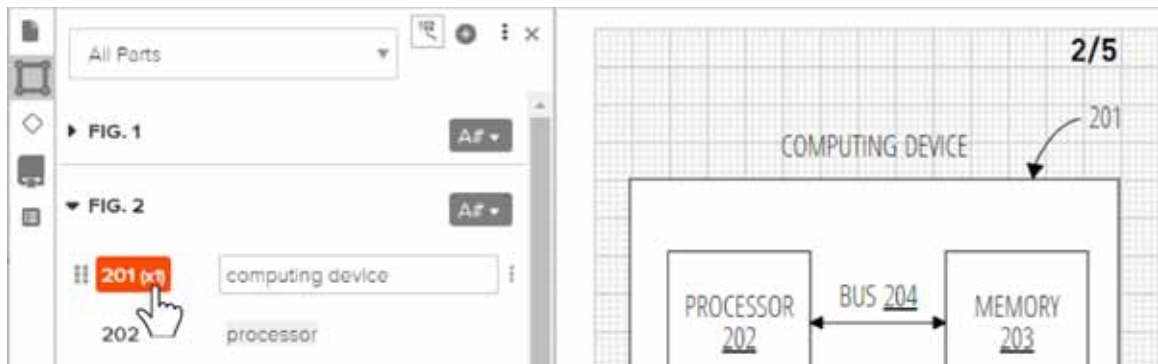

*Autonumbering can be further customized by changing the part numbering increment.*

## Select Autonumbering for All Figure Lists

1. Open the Drawing Tool and expand the Parts Panel (shown above).

2. Click the menu icon to the upper-right of the Parts Panel.

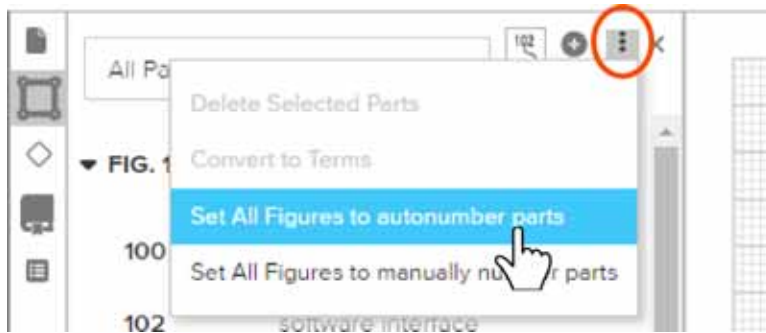

3. Select the Set All Figures to autonumber parts option.
4. Confirm your selection in the confirmation dialog.

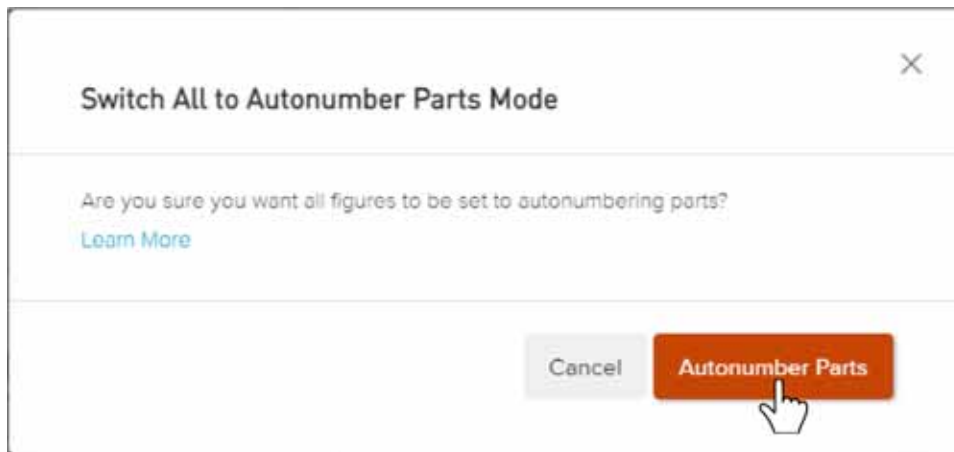

## Change Part Autonumbering Increment

### Change Increment for a Single Part

1. Expand the Parts Panel in the left-hand sidebar of the Drawing Tool.
2. Locate the autonumbered part you wish to set a different numbering increment for.
3. Click the part number to bring up the Change Part Number menu.

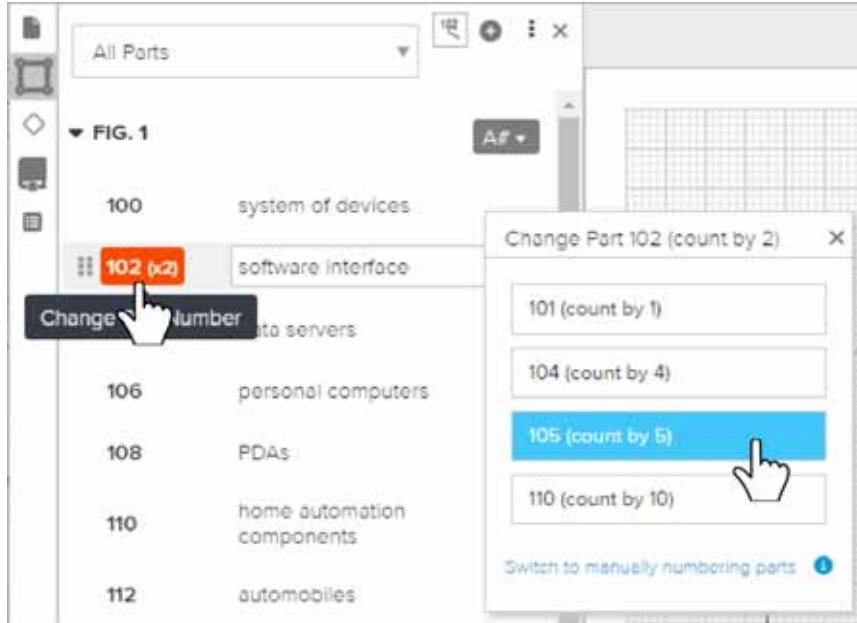

4. Select the desired numbering increment. A preview of the updated part number is displayed.

*Autonumbered parts can now be numbered by 1s, by 2s, by 4s, by 5s, or by 10s.*

5. The numbering increment for that part will be changed and will be maintained as parts are reordered.

*Note that this increment setting will also be applied to new parts you create by typing Enter after the part name for this part.*

## Change Increment for a Range of Parts

1. Expand the Parts Panel in the left-hand sidebar of the Drawing Tool.
2. Select the autonumbered parts you wish to set a different numbering increment for.
3. Click the Select Increment option in the multi-part operations menu available from the icon at the top of the Parts Panel.

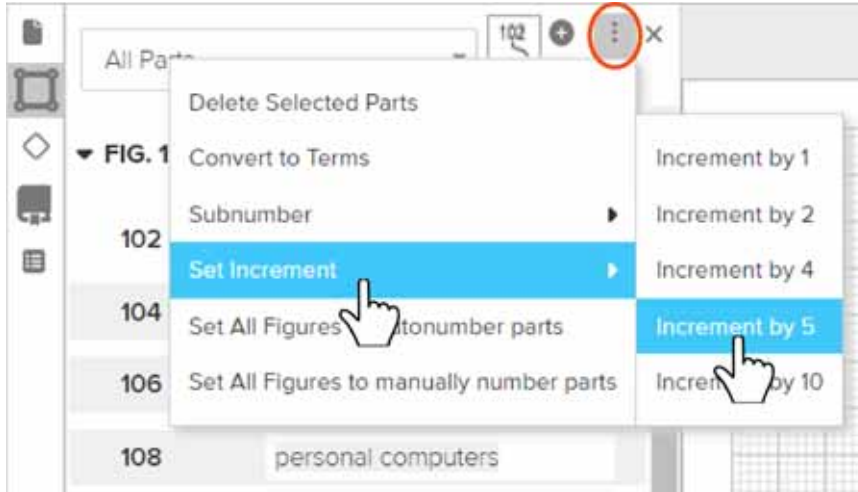

4. Select the desired increment option.
5. The numbering increment will be changed for the selected parts and will be maintained as parts are reordered.

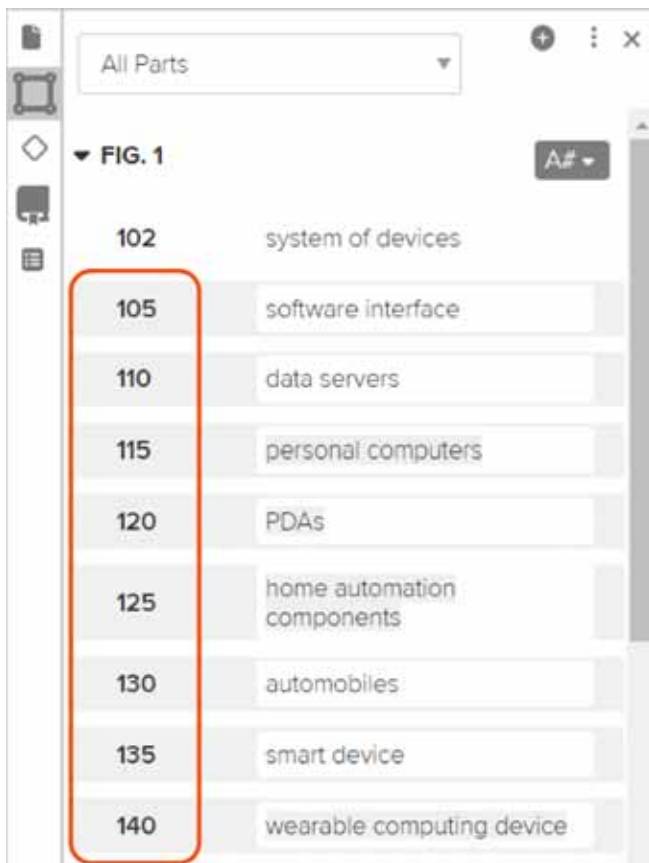

# Select Manual Numbering Mode for Parts

## Manual Numbering Mode Overview

Manual numbering mode allows an even greater level of flexibility to match an even broader set of workflows and numbering preferences. Users can simply enter whatever number (and suffix) they want. Part references in the specification will still be synced and will automatically update when changes are made in the drawing tool. However, this mode does not benefit from some of the other automations – e.g. maintaining an order when renumbering or reordering figures. This mode also allows multiple parts to have the same number, at which point the system will provide a warning.

## Select Manual Numbering for One Figure List

1. Open the Drawing Tool and expand the Parts Panel in the left-hand sidebar.

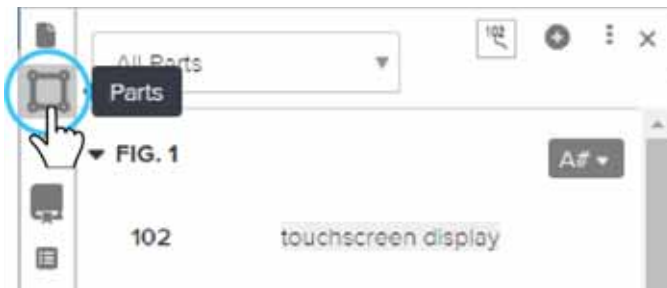

2. Click the Part Numbering Mode control in the upper-right corner of the desired figure parts list.

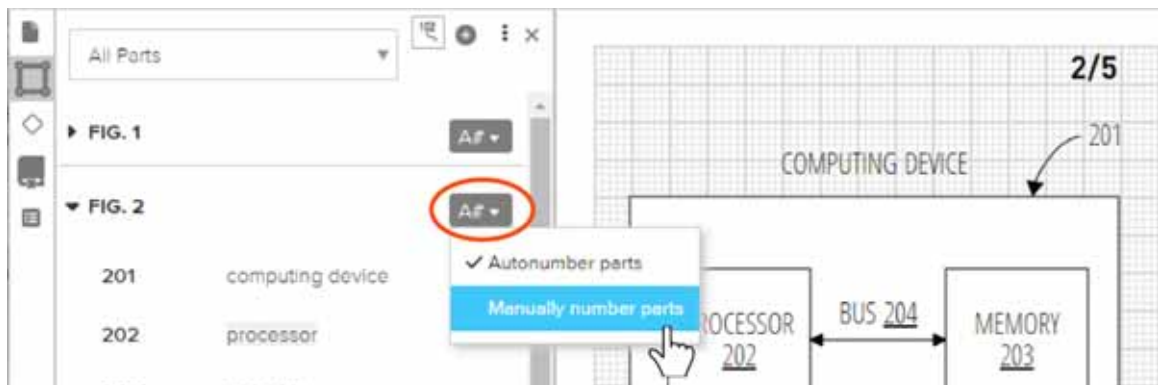



Note that parts are collected into lists for each figure and that the numbering mode will be applied to the entire figure list.

3. Select the Manually number parts option for the figure list.
4. Confirm your selection in the dialog presented.



5. The parts in that figure list will remain the same, but can now be adjusted by typing in a desired part number.

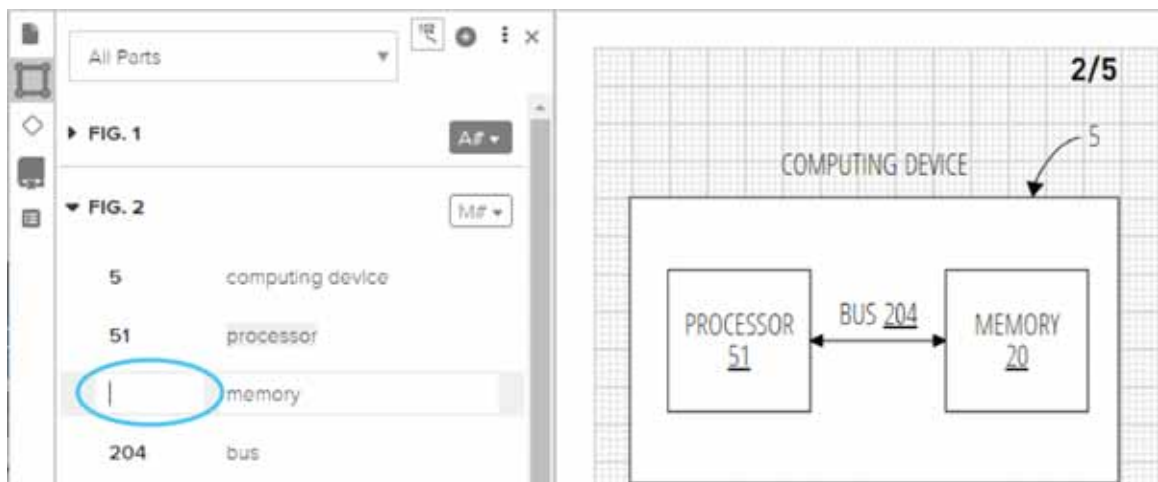

## Select Manual Numbering for All Figure Lists

1. Open the Drawing Tool and expand the Parts Panel (shown above).
2. Click the menu icon to the upper-right of the Parts Panel.

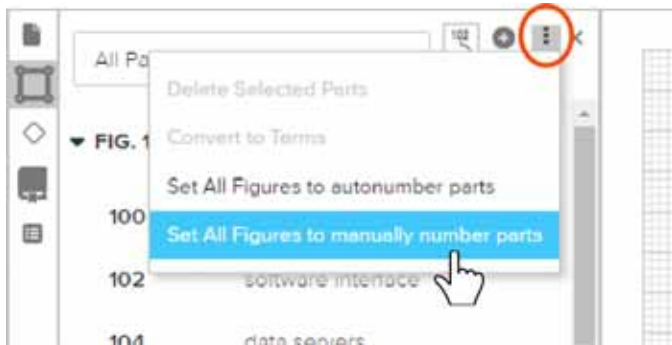

3. Select the Set All Figures to manually number parts option.
4. Confirm your selection in the confirmation dialog.

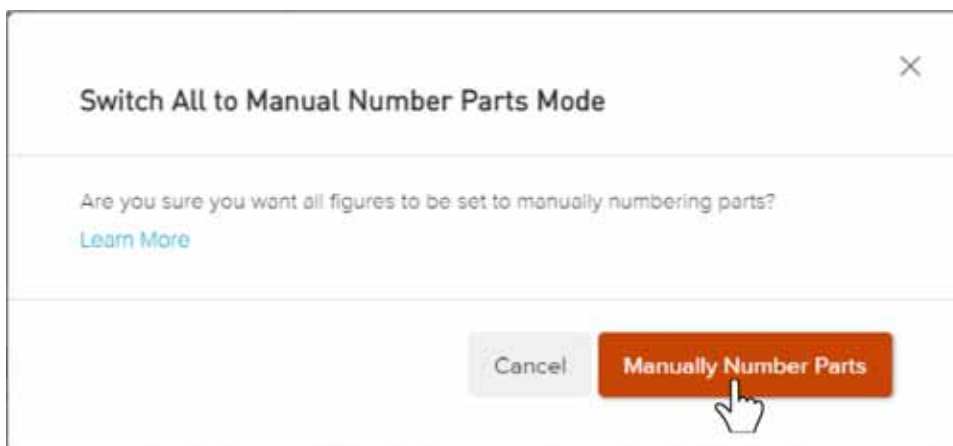

## Create a Figure (X00) Part

### Add a Figure Part in the Parts Panel

1. Open the Drawing Tool and expand the Parts Panel in the left-hand sidebar.

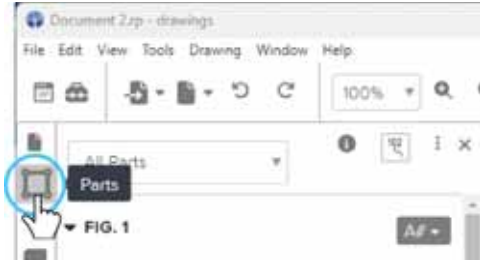

2. Scroll to the figure list where you want to add a figure part.
3. Click the Add Figure Part control provided where a figure part has not yet been identified.



4. A figure part will be created in that figure list, with a field allowing you to enter a part name.

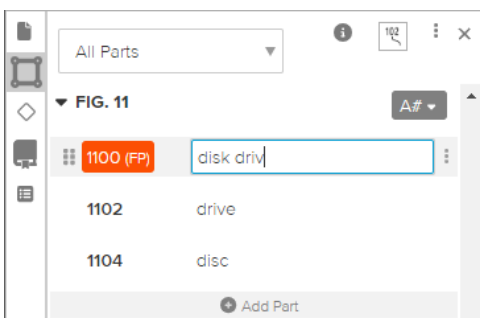

*Note that for manual numbering, a default number will be populated, and may be changed by typing the desired number in the part number field.*

5. Add your figure part to the drawing canvas.

*By default, your figure part will be placed as a numbered, arched arrow pointing down and to the left.*

## Convert a Part to a Figure Part

1. Open the Drawing Tool and expand the Parts Panel in the left-hand sidebar.

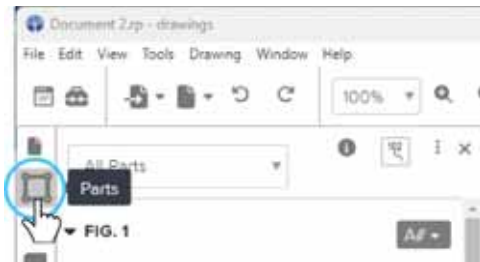

2. Create or locate the part you want to set as your top-level or figure-level, #00 numbered part in the Parts Panel.
3. If necessary, reorder that part to be the first part in its figure list.
4. Click the part number to bring up the Change Part Number menu.

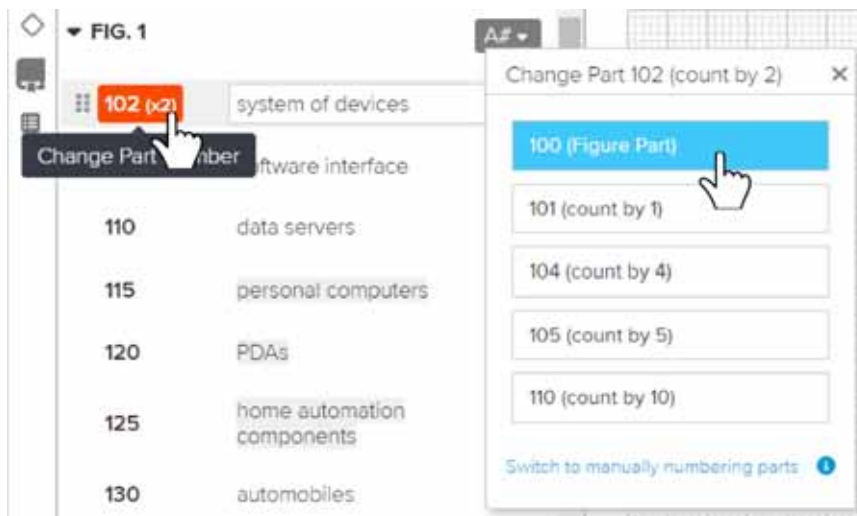

5. Select the "#00 (Figure Part)" option (where # is the number of the figure the part

is listed for).

*Note that this option is ONLY displayed for the first part in a figure's list.*

6. Your part will be labeled (FP) as a figure part and, for autonumbered figures, renumbered as #00.

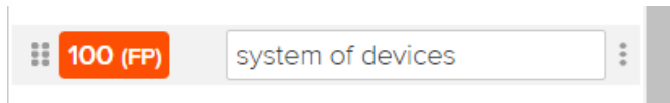

7. Add your figure part to the drawing canvas.

*By default, your figure part will be placed as a numbered, arched arrow pointing down and to the left.*

## Select Multiple Parts

### Multiselect Parts in the Parts Panel

1. Click the Parts panel listing for the first part you wish to select.
2. Ctrl+Click additional part listings (Cmd+Click for Macs) to add one additional part at a time to your selection.
3. Shift+Click a part listing at the end of a desired set of listings to select the entire range of parts in the set.



*Note that parts from multiple figures can be selected at the same time in the Part Panel, as a single range or set.*

## Reorder Parts and Move Parts to a Different Figure

1. Open the Drawing Tool and expand the Parts Panel in the left-hand sidebar.
2. Click the move icon to the left of the part number for the part you wish to reorder.

OR Select multiple parts and click the move icon next to any of the selected parts.

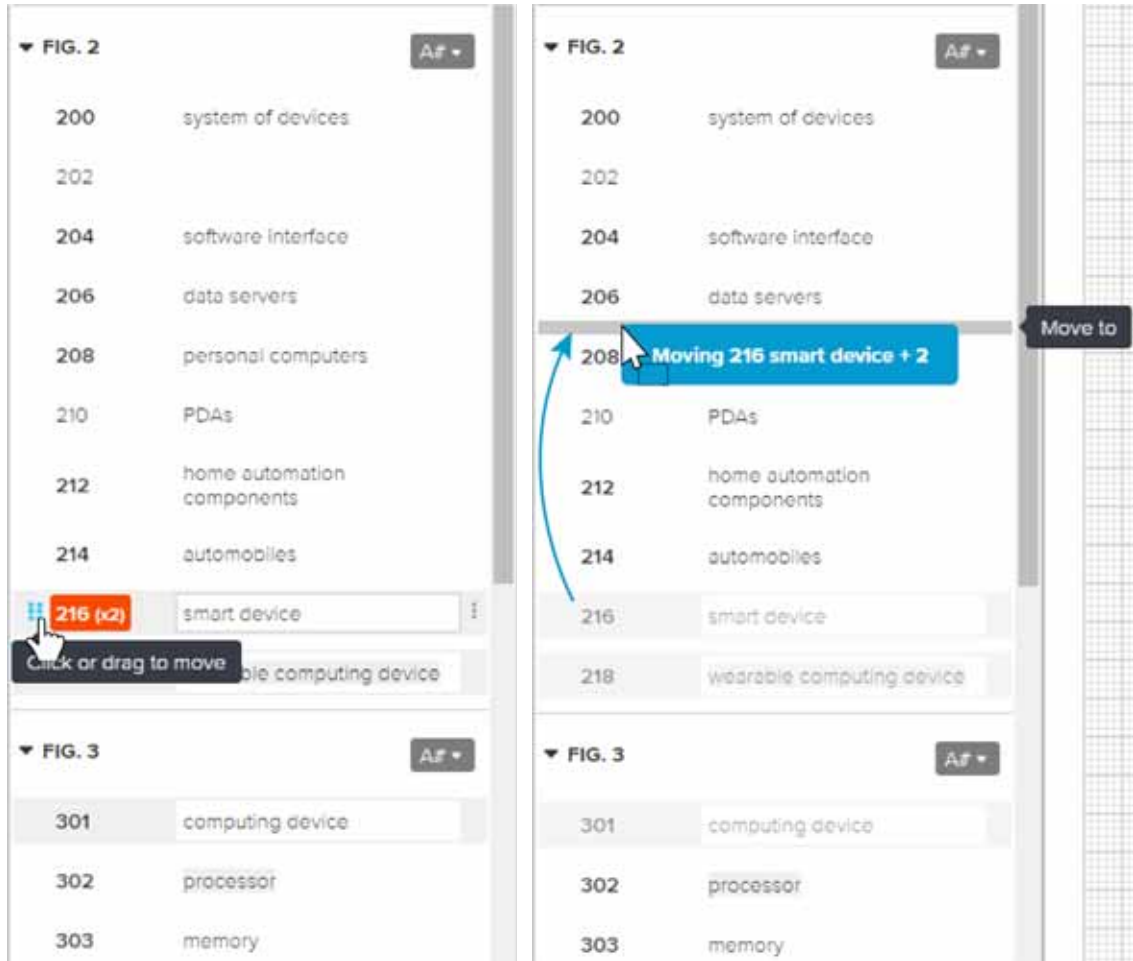

3. Mouse or drag the selected part(s) to another location within their figure list, or to a location in a different figure list.

*A gray selection bar will indicate available drop locations as you mouse over them.*

4. Click or drop your parts on the selection bar at your desired new location.

▼ FIG. 2		Aut ▼
200	system of devices	
202		
204	software interface	
206	data servers	
208	smart device	
210	wearable computing device	
211	computing device	
212	personal computers	
214	PDAs	
216	home automation components	
218	automobiles	
▼ FIG. 3		Aut ▼
301	processor	
302	memory	

*Note that parts moved to a new figure list will be numbered according to the numbering mode (autonumbering or manual numbering) selected for that figure list. However, autonumbering increments will be preserved when moving between autonumbered lists.*

## Merge Parts

### Why Merge Parts?

When you open or import an application created outside of Rowan, a particular reference numeral for a figure element may be associated with more than one element name, either intentionally (e.g., processor 102 and CPU 102) or in error through typos, copy and paste issues, source text inconsistencies, or a number of other reasons (e.g., processor 102, CPU 102, processor 202, memory 102, and memory 104).



In the latter case, you may only want two reference numerals, 102 and 104, for your processor/CPU and memory, respectively. Our manual part numbering option will support instances where you want one numeral to have name variations, but where part numbers are created in error, Merge Parts lets you merge, say, memory 102 with the desired memory 104, and processor 202 with processor 102, replacing all drawing instances and spec and claims references with the numeral and name you want.

While our existing functionality lets you easily reuse a single part across multiple figures, you may also find at some point during drafting that you've intentionally created two (or more) parts but now you only want one. Merge Parts also lets you quickly replace all drawing instances and text references for any unnecessary numerals with the one numeral you really need.

## Merge a Single Part with a Desired Part

1. Locate the extra part you wish to merge with a desired part or a stencil associated with it.
2. Select the Merge Parts option from the menu available through the icon to the right of the part name in the Parts panel, the toolbar, the Element Info controls in the right-hand sidebar, or the on-canvas controls available when the stencil is double-clicked.

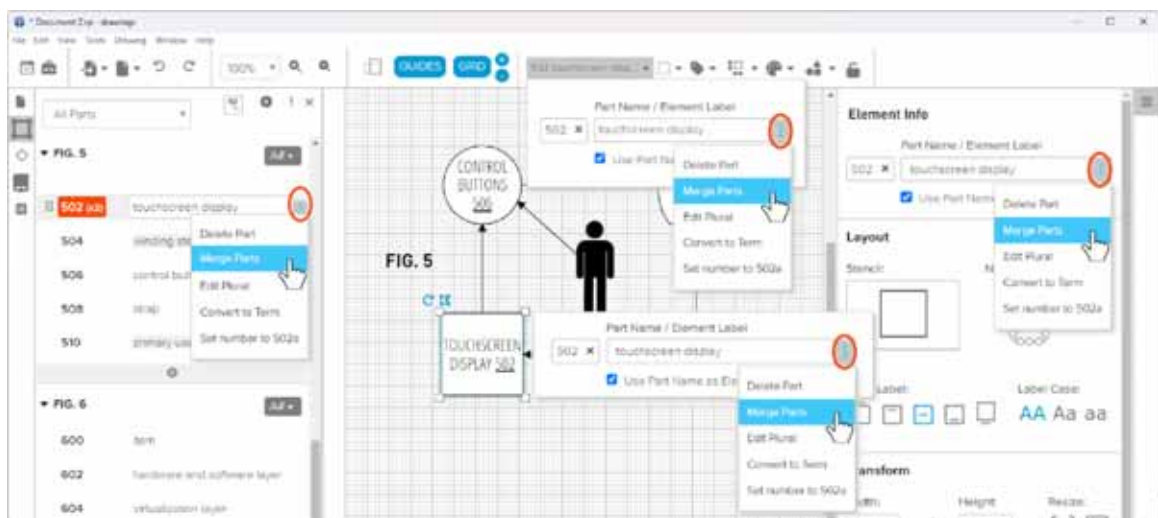

3. Select the desired part from the menu presented.

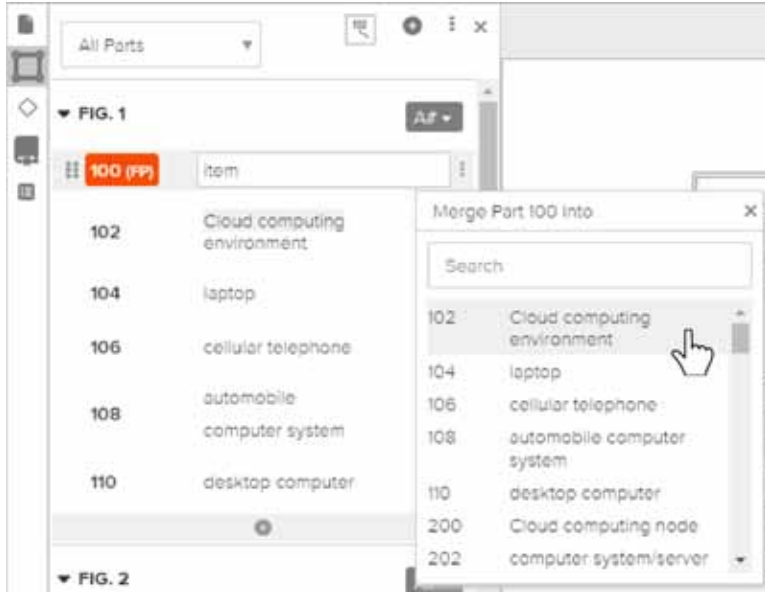

4. Confirm your merge action in the dialog provided.

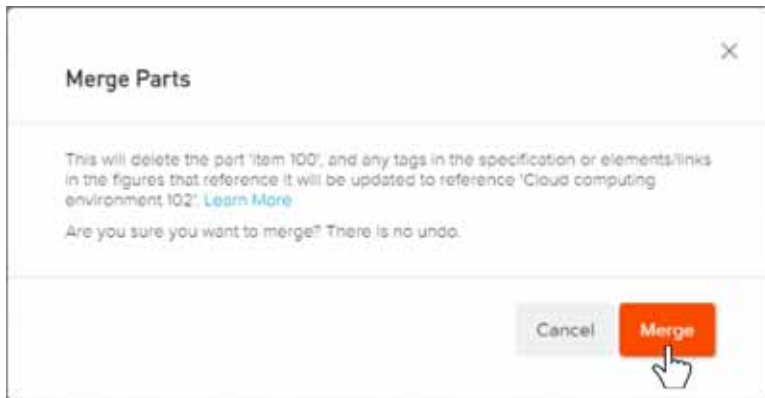

5. The extra part will be removed from its Figure list, and all text references and drawing instances will take on the part data for the selected desired part.

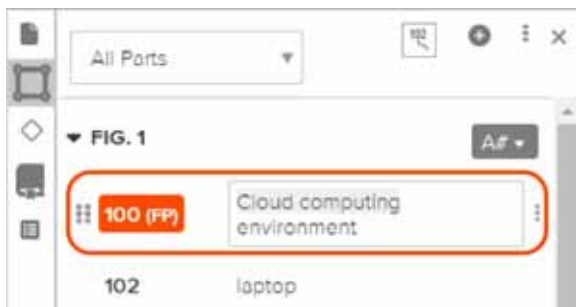

## Merge Multiple Parts with a Desired Part

1. Open the Drawing Tool and expand the Parts Panel in the left-hand sidebar.



2. Select the extra parts and the desired part you wish to merge together.



3. Click the Merge Selected Parts option in the menu available at the top of the parts panel.
4. Select the desired part from the list presented.

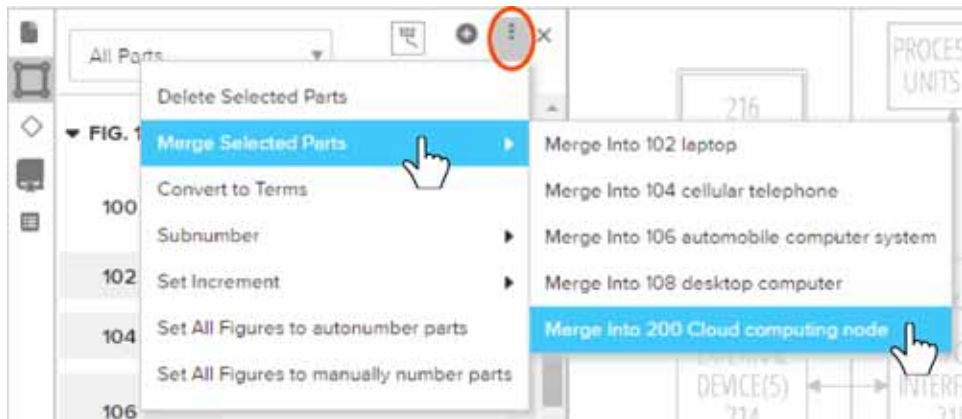

5. Confirm your merge action in the dialog provided.

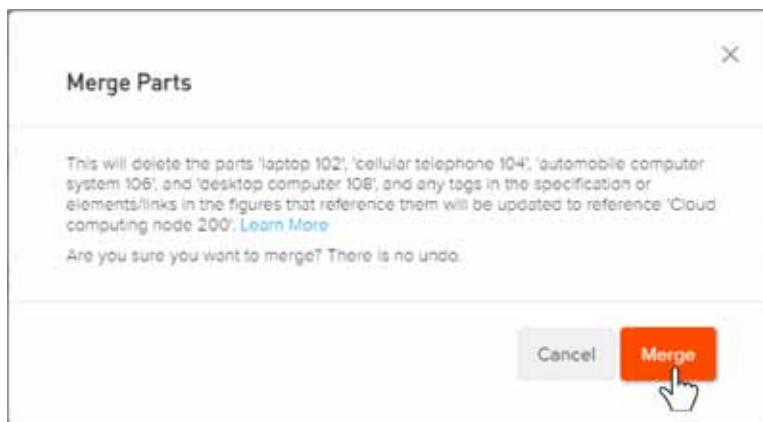

6. The extra parts will be removed from their Figure lists, and all text references and drawing instances will take on the part data for the desired part.

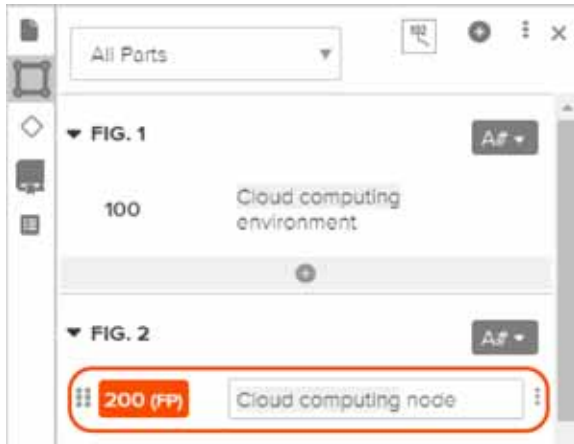

## Subnumber Parts

### Subnumber Individual Parts

1. Locate the autonumbered part you want to subnumber with an alphabetic suffix or a stencil associated with the part.

*Note that for manually numbered parts, a subnumbering suffix may simply be typed into the part number field when the part is created.*

2. Select the desired "Set number to" option from the menu available through the icon to the right of the part name in the Parts panel, the toolbar, the Element Info controls in the right-hand sidebar, or the on-canvas controls available when the stencil is double-clicked.

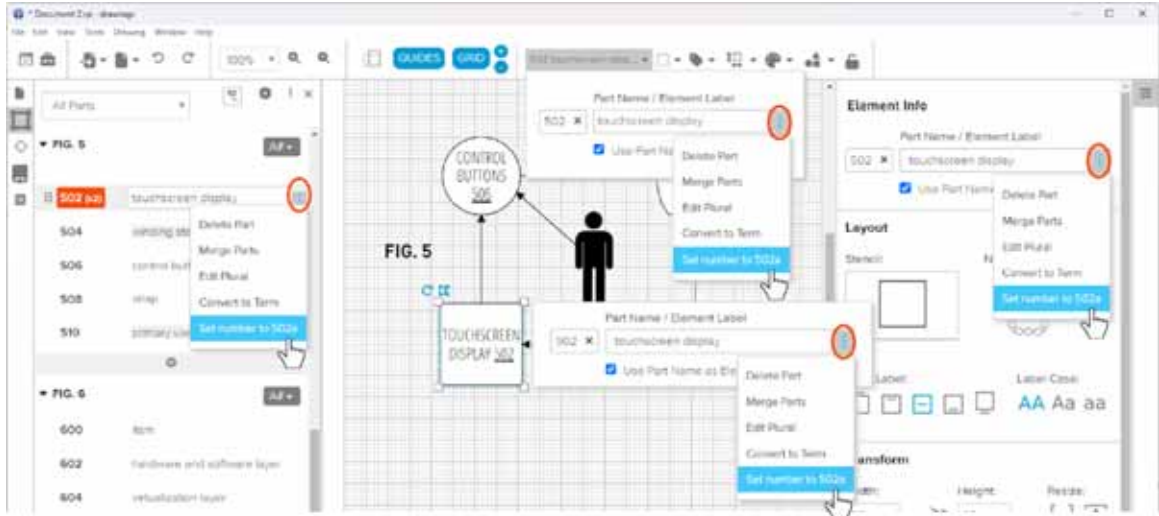

3. Parts will be subnumbered according to your selection.

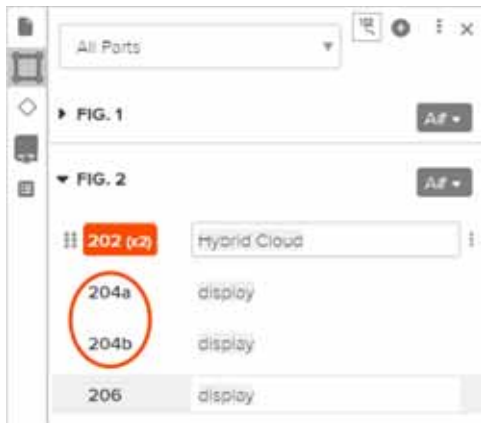

4. Repeat for each part you want to include in a subnumbered set.

*Note that if a part has been placed as a stencil on the drawing canvas, it can also be subnumbered using controls available to the right of the canvas when the stencil is selected.*

## Subnumber a Set of Parts

1. Locate the autonumbered parts you want to subnumber with an alphabetic suffix in the Parts Panel in the left-hand sidebar of the Drawing Tool.

2. Select all parts you wish to subnumber.
3. Click the Subnumber option from the multi-part operations menu at the top of the Parts Panel and select the presented subnumbering option.

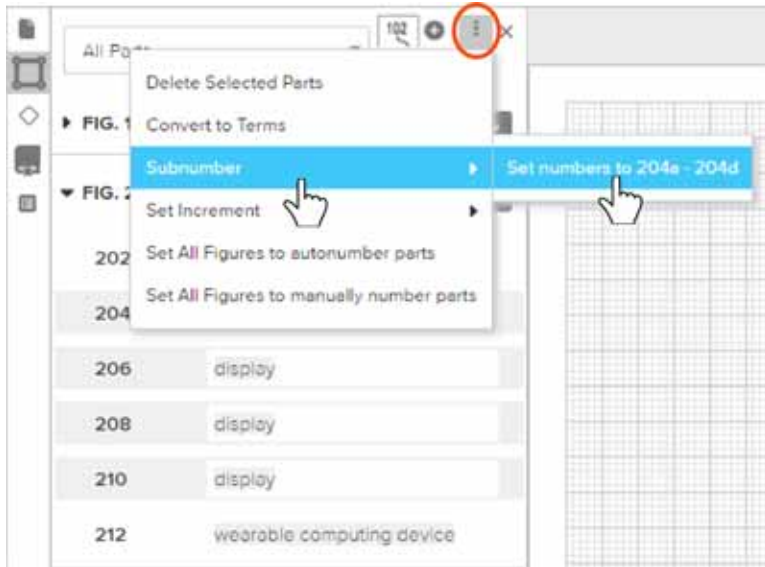

4. Your selected set of parts will be subnumbered as indicated.

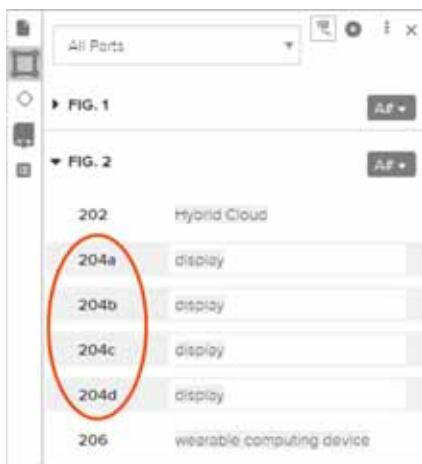

## Remove Subnumbering from a Part

1. Locate the part you want to remove the alphabetic suffix from in the Parts Panel in the left-hand sidebar of the Drawing Tool, or locate a stencil associated with that part.

2. Select the "Set number to" option from the menu available through the icon to the right of the part name in the Parts panel, the toolbar, the Element Info controls in the right-hand sidebar, or the on-canvas controls available when the stencil is double-clicked.

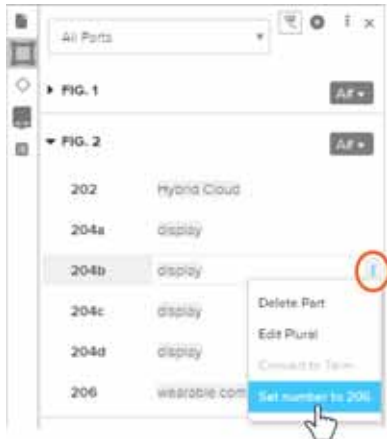

*See above for additional menu location options.*

3. The selected part will be moved out of the subnumbered set to the next available part number.

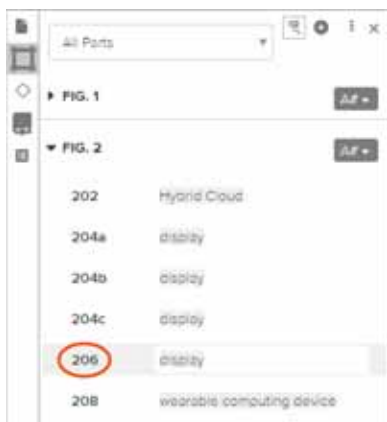

*Note that if a part has been placed as a stencil on the drawing canvas, it can be unnumbered using controls shown to the right when the stencil is selected.*



# Convert a Part Name to a Term

## How to Convert a Single Part Name to a Term

1. Locate the part you wish to convert to a term in the Parts Panel in the left-hand sidebar of the Drawing Tool, or locate a stencil associated with that part.
2. Select the Convert to Term option from the menu available through the icon to the right of the part name in the Parts panel, the toolbar, the Element Info controls in the right-hand sidebar, or the on-canvas controls available when the stencil is double-clicked.

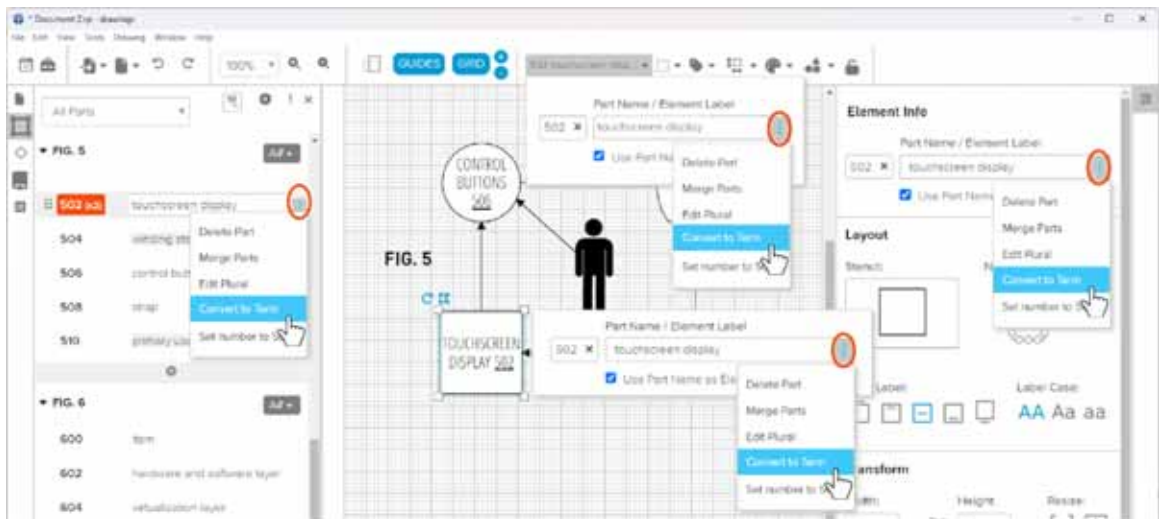

3. Your part's part name will be converted to a term data object, shown with gray highlighting, and can be tracked and managed across your Rowan Patents .rp application.



*Note that if a part has been placed as a stencil on the drawing canvas, it can also*

*be converted to a term using controls available to the right of the canvas when the stencil is selected.*

## How to Convert a Set of Part Names to Terms

1. Locate the parts you wish to convert to terms in the Parts Panel in the left-hand sidebar of the Drawing Tool.
2. Select all of the parts you wish to convert to terms.
3. Select the Convert to Terms option from the multi-part operations menu available at the top of the parts panel.

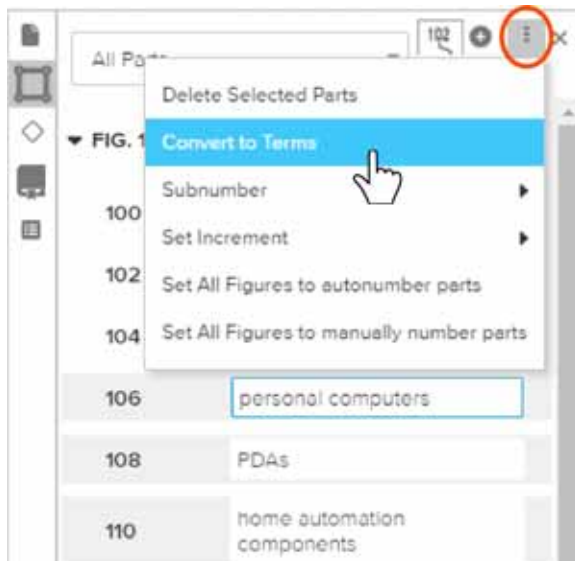

4. Part names for your selected parts will be converted to term data objects, shown with gray highlighting, and can be tracked and managed across your Rowan Patents .rp application.



# Edit Part Name Pluralization

1. Locate the part you wish to edit the plural form for in the Parts Panel in the left-hand sidebar of the Drawing Tool, or locate a stencil associated with that part.
2. Select the Edit Plural option from the menu available through the icon to the right of the part name in the Parts panel, the toolbar, the Element Info controls in the right-hand sidebar, or the on-canvas controls available when the stencil is double-clicked.

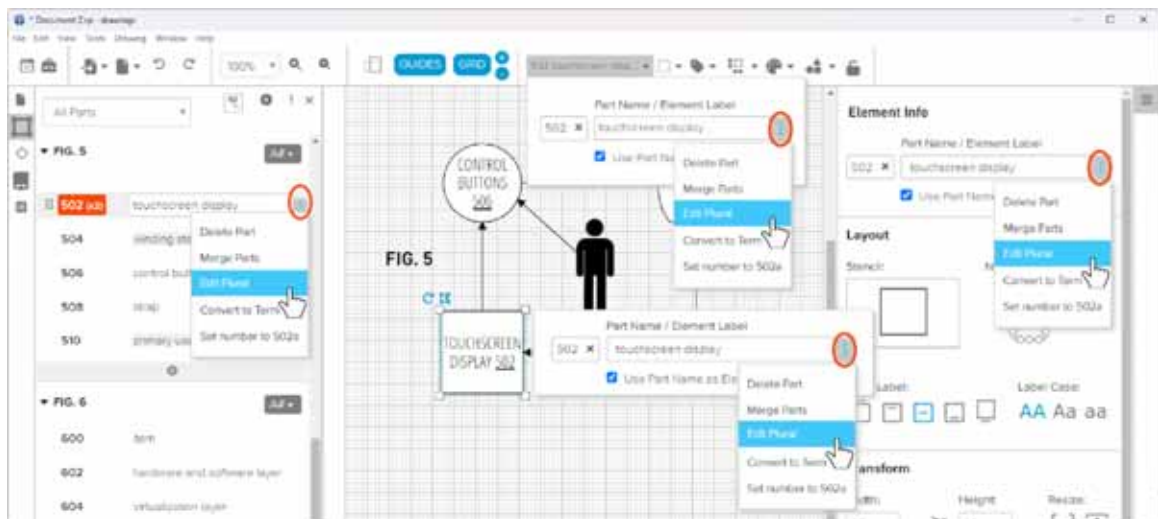

3. Click the Edit plural control in the dialog provided.

**Edit Part Name** [X]

Part Name  
antenna

Plural: antennae

**Edit plural**

Cancel Save

4. Type the desired plural form and click Save.

**Edit Part Name** [X]

Part Name  
antenna

Plural: antennas **Auto-generate**

Cancel Save

*Note that to return to the auto-generated plural form, you can follow the steps above, and click the Auto-generate control provided.*

*Note that if a part has been placed as a stencil on the drawing canvas, its plural can also be edited using controls available to the right of the canvas when the*

*stencil is selected.*

## Filter and Collapse Parts Panel Lists

### Filter Parts with the Filter Dropdown

1. Locate the filter dropdown at the top of the Parts panel.

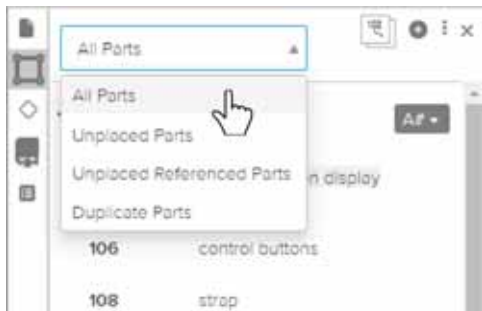

2. Click the dropdown and select from the options presented:

- **All Parts** (every part created by any action)
- **Unplaced parts** (parts that have no associated stencil on any figure canvas)
- **Unplaced referenced parts** (parts with no associated stencil, but that are referenced in the specification or claims)
- **Duplicate parts** (parts with the same number as other parts - only occurs when at least one figure list is manually numbered)

*Note that parts that are associated with a placed stencil, but are not referenced in your application text will be indicated in the [Consistency Review](#) tool.*

*Note that these filters can be combined with [multiple part selection](#) to quickly complete operations for multiple parts, such as deleting all unplaced parts.*

## Collapse Figure Parts Lists

1. Locate a figure parts list you wish to collapse in the Parts panel.
2. Click the downward-pointing triangle to the left of the FIG. # heading to collapse that figure list.

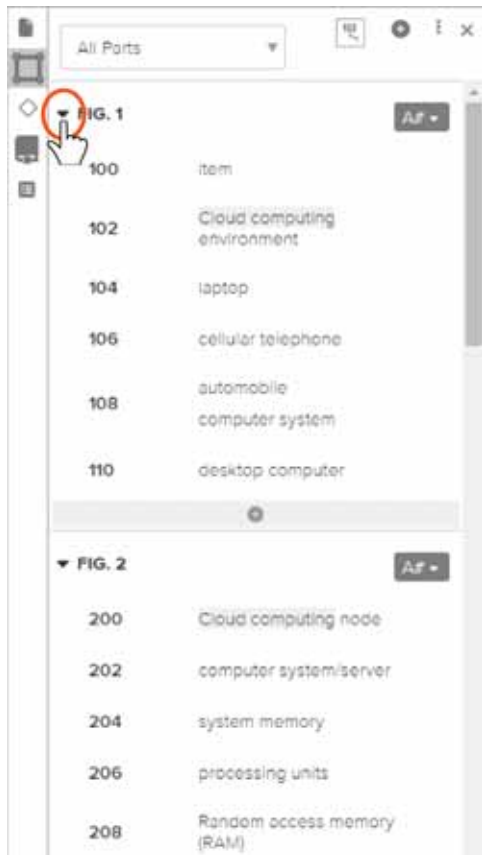

3. To re-expand a collapsed figure list, click the right-pointing triangle to the left of the FIG. # heading.

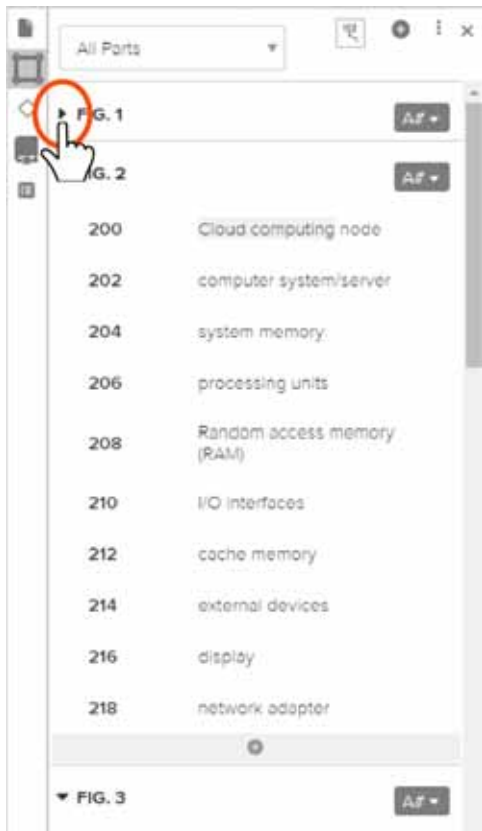

## Delete Parts

### Delete a Single Part

1. If desired, filter the parts list to facilitate deleting one of a category of parts.
2. Locate the part you wish to delete in the Parts Panel in the left-hand sidebar of the Drawing Tool or select a stencil associated with that part.
3. Select the Delete Part option from the menu available through the icon to the right of the part name in the Parts panel, the toolbar, the Element Info controls in the right-hand sidebar, or the on-canvas controls available when the stencil is double-clicked.

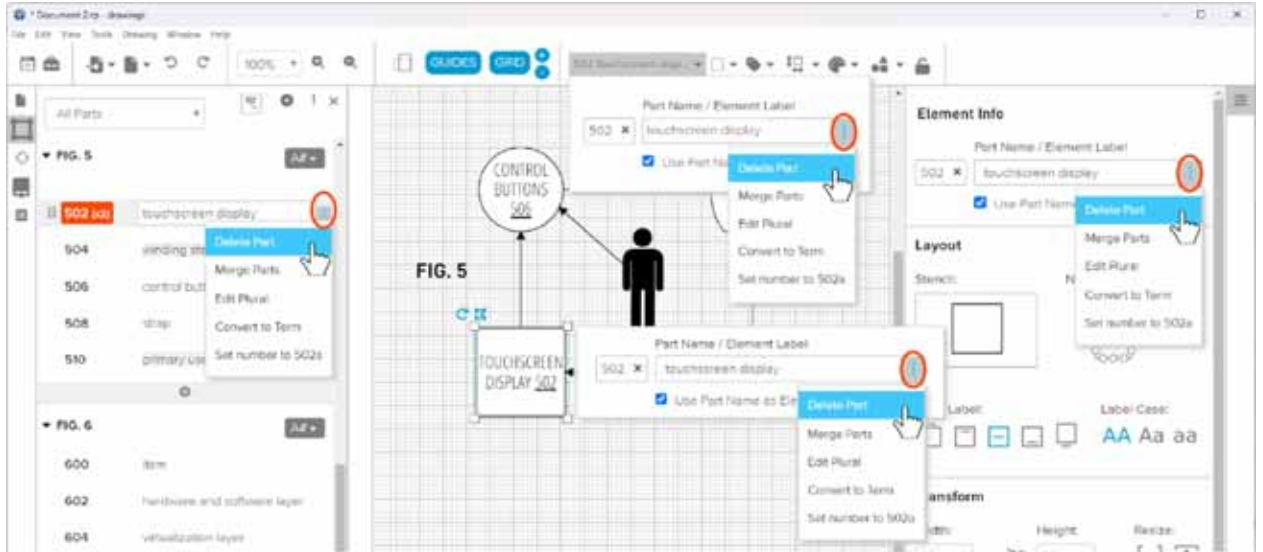

4. If your part is referenced in your application and/or appears in your figures, confirm your deletion in the dialog provided.

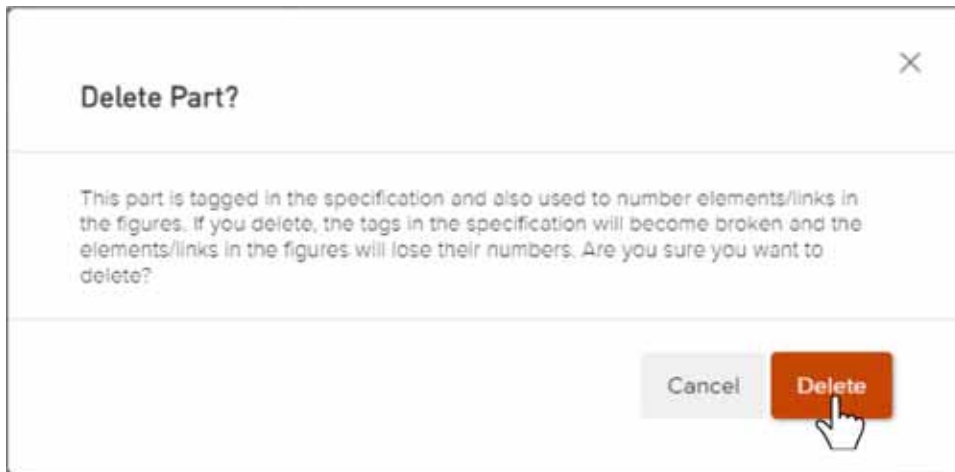

*Note that deleting a part will remove the part data from the on-canvas stencil associated with the part, but will not remove the stencil. The stencil may be deleted separately if desired.*

*Note that if a part has been placed as a stencil on the drawing canvas, it can also be deleted using controls available to the right of the canvas when the stencil is selected.*



## Delete Multiple Parts

1. If desired, filter the parts list to facilitate deleting all of a category of parts.
2. Select all of the parts you wish to delete.
3. Click the menu icon for Multi-Part Operations at the upper-right of the Parts panel and select the Delete Selected Parts.

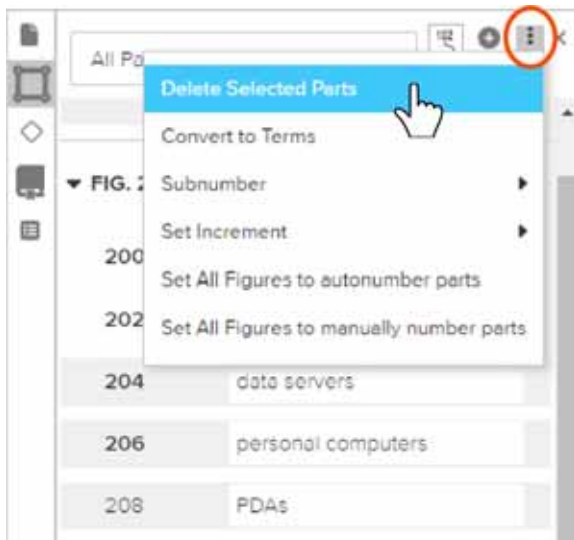

4. If your parts are referenced in your application and/or appear in your figures, confirm your deletion in the dialog provided.

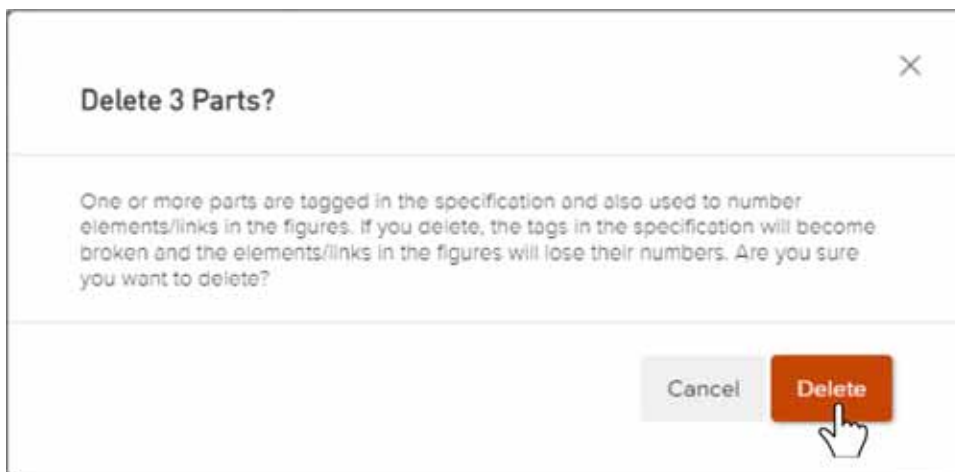

*Note that deleting parts will remove the part data from the on-canvas stencils associated with the part, but will not remove the stencils. The stencils may be deleted separately if desired.*

*Note that all parts for a figure will be deleted when their figure is deleted.*

## Add Elements to a Drawing Canvas

### Add Parts to the Canvas from Menu

1. Open the Drawing Tool and expand the Parts Panel in the left-hand sidebar.

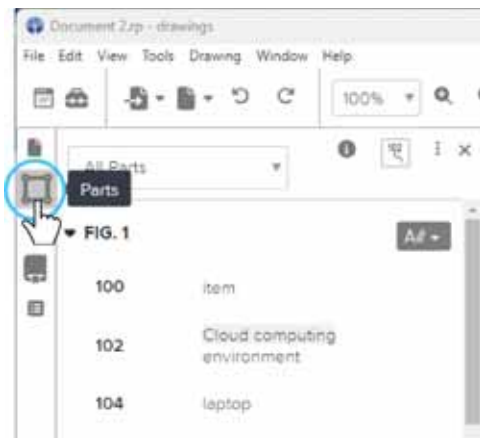

2. If desired, filter the parts list for Unplaced Parts or Unplaced Referenced parts to identify parts that may need to be added to a figure canvas.

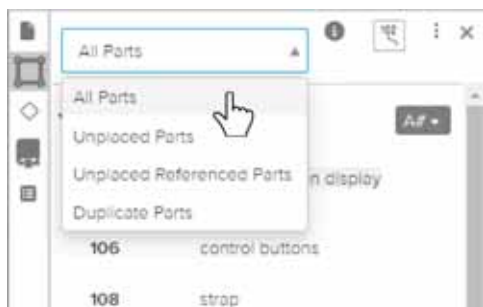

3. Select one or more parts from the Parts Panel.

4. Select Add to Canvas from either the single part menu to the right of a selected part, or the multi-part menu at the top of the parts panel.

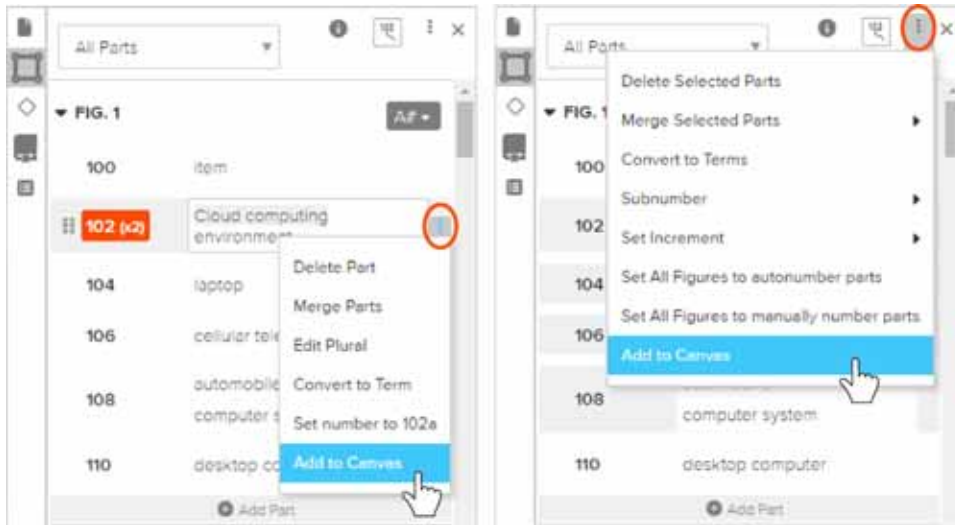

*Note that a part from any figure list in the Parts Panel can be used both in that figure and any other figure, any number of times.*

5. Your parts will be placed at the top of the canvas using the default, part number with lead line stencil. This can be changed as desired using the Default stencil for parts control at the top of the Parts Panel.

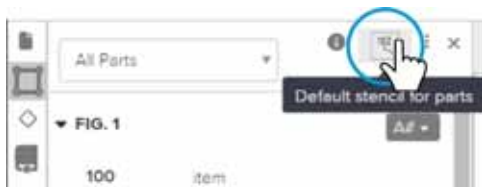

## Drag and Drop Parts onto the Canvas

1. Open the Drawing Tool and expand the Parts Panel in the left-hand sidebar.



2. If desired, filter the parts list for Unplaced Parts or Unplaced Referenced parts to identify parts that may need to be added to a figure canvas.

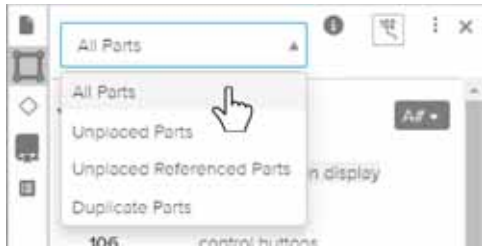

3. Select one or more parts from the Parts Panel.
4. Click the move icon to the left of the selected part(s).



5. Drag your selected part(s) onto the drawing canvas for the desired figure.

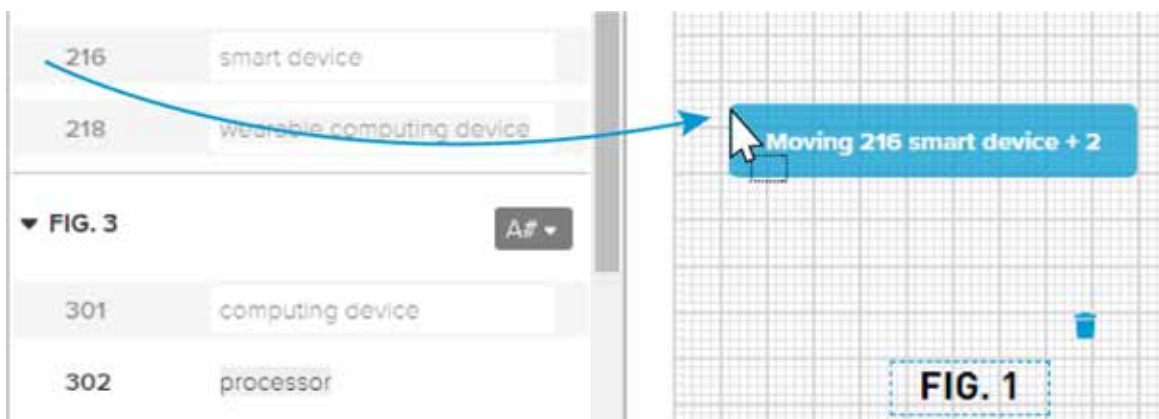

*Note that a part from any figure list in the Parts Panel can be used both in that figure and any other figure, any number of times.*

6. Your parts will be populated using the default, part number with lead line stencil. This can be changed as desired using the Default stencil for parts control at the top of the Parts Panel.

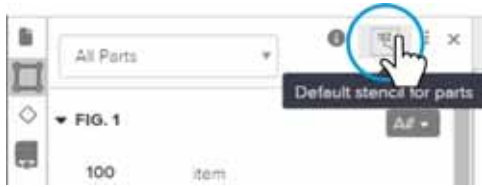

## Drag and Drop a Stencil onto the Canvas

1. Open the Drawing Tool and expand the Stencils Panel in the left-hand sidebar.
2. Click and drag the desired stencil from the Stencils Panel onto the drawing canvas.

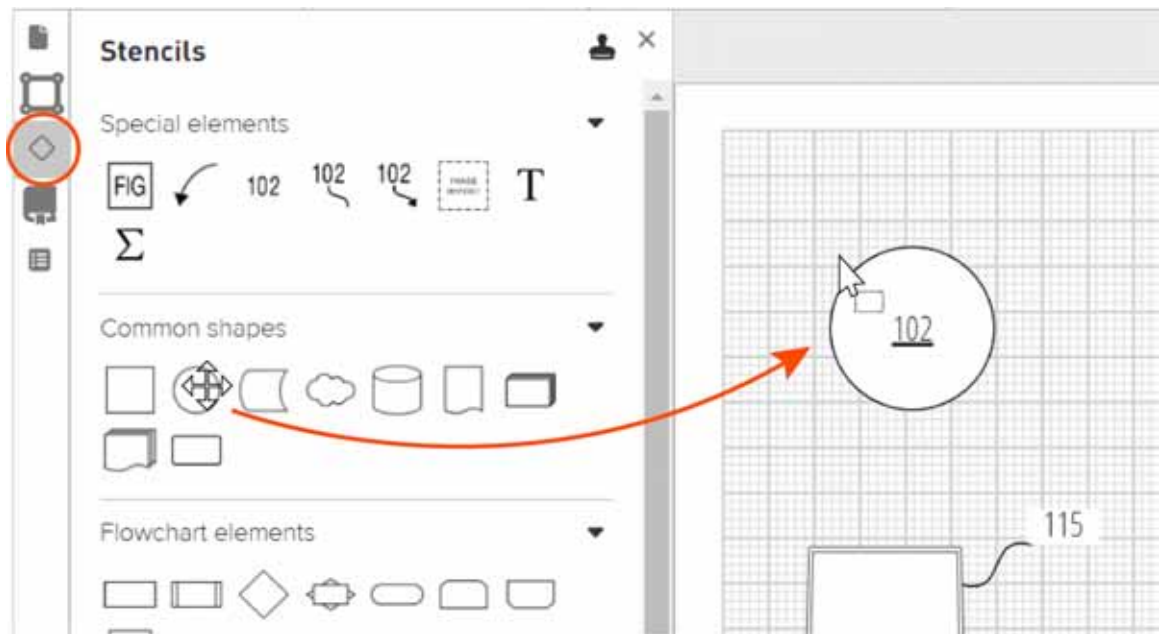

3. Drop the stencil at your desired location.
4. Your new stencil will have a new part number and a listing in the Parts panel under the figure list for the figure you placed it on.

## Drag and Drop a Term onto the Canvas

1. Open the Drawing Tool and expand the Terms Panel in the left-hand sidebar.
2. Click and drag the desired term onto the canvas to place the term as a number stencil with a leadline

OR shift+click and drag the desired term onto the canvas to place the term as a rectangle stencil.



3. Drop the term at the desired location to place the stencil and create a part having that term as its part name.

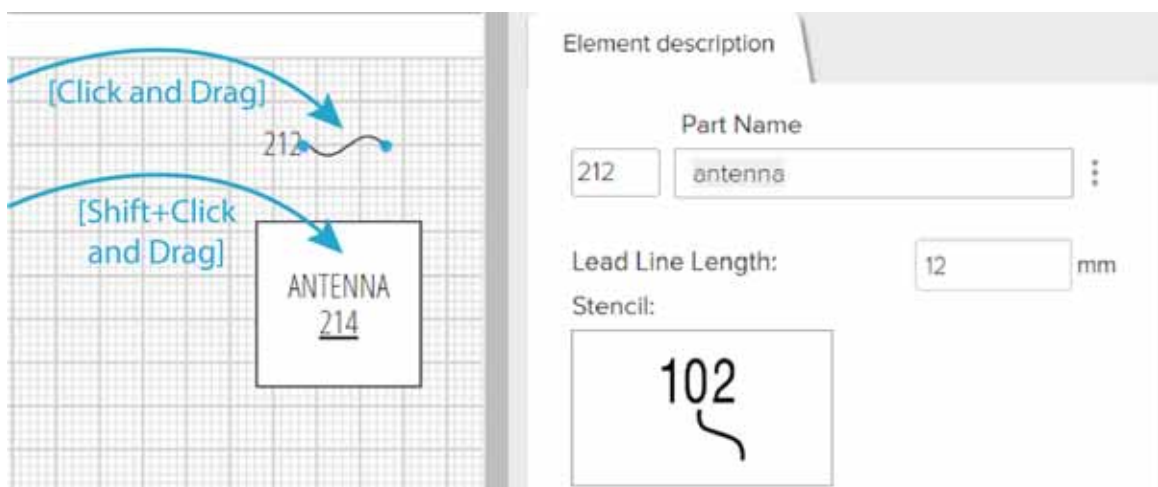

## Copy and Paste or Paste with New Number

*Note that Ctrl+V (Cmd-V) and Ctrl+Shift+B (Cmd+Shift+B) actions now produce the opposite results from their previous functions.*

1. Select one or more stencils on the drawing canvas.
2. Copy the stencil(s) using Ctrl+C (Cmd-C for Macs) or the Copy option under the Edit menu.
3. Paste identical stencil(s) with identical part data using Ctrl+V (Cmd-V for Macs) or the Paste option under the Edit menu.

OR paste the stencil(s) with new part data using Ctrl+Shift+B (Cmd-Shift-B for Macs) or the Paste with New Number option under the Drawing menu.

4. Stencil(s) will be placed on the canvas with either identical or new part data as described above, and identical appearance attributes.

## Quick Connect Two Stencils with a Connector Line

1. Click to select a stencil on the canvas.
2. Click the blue arrow to the right of the stencil, and drag a connector line out from the stencil.

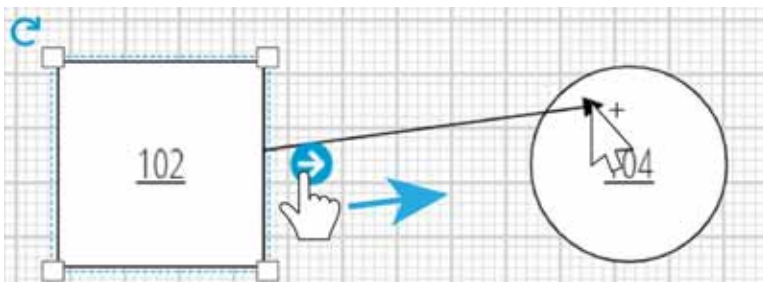

3. Drop the connector line end point onto the stencil you wish to connect.

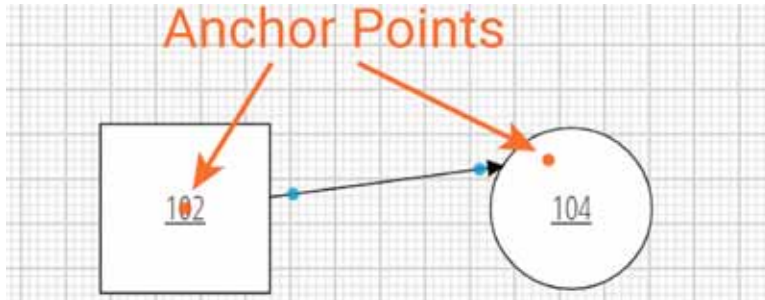

Note that two orange anchor points will appear when the connector line is properly connected to both stencils.

connector lines are intended to be visual connectors between stencils, and do not behave as stencils on their own. It is recommended that you anchor both ends of a connector line as a best practice. If a visible shape is not desired, a small stencil with an invisible border can be created to allow anchoring at both connector line ends.

## Add a Connector Line from the Stencils Panel

1. Click and drag a connector line from the connector lines palette in the left-hand Stencils panel onto the drawing canvas.

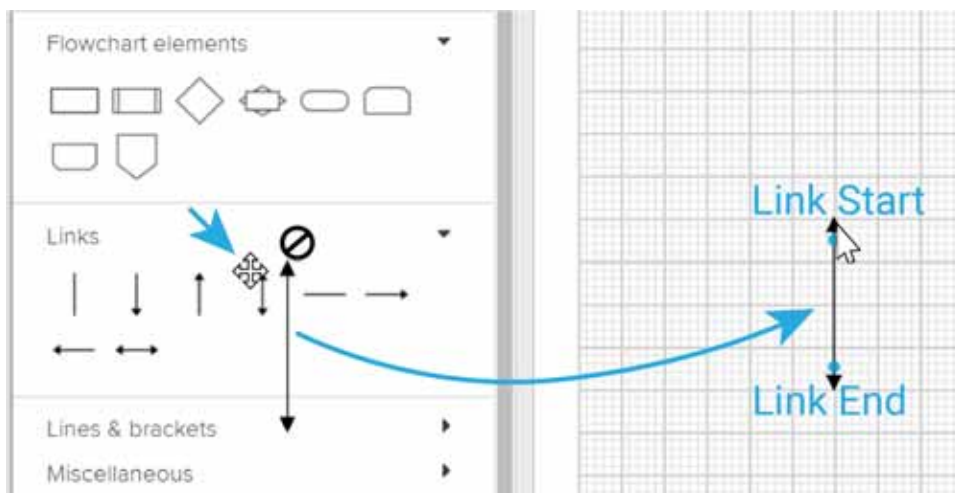

2. Click the blue start and end points in turn and drag and drop them onto the stencils you wish to connect, as described above.



# Select Stencils and Connector Lines

## Click to Select a Single Stencil

1. Click your mouse cursor on the desired stencil.

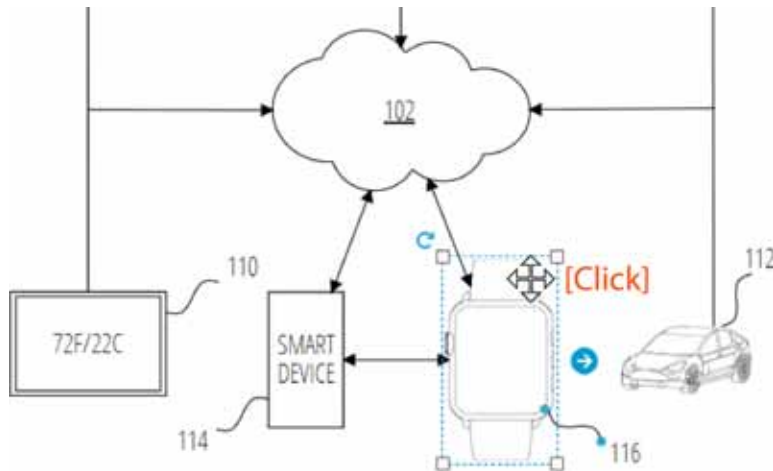

2. The clicked stencil will be selected and a blue, dashed boundary box will be displayed to indicate your selection.

*Note that if a stencil has been locked to the canvas a solid gray boundary box will be displayed.*

## Click to Select Multiple Stencils

1. Click your mouse cursor on one of the desired stencils.
2. Shift+click or Ctrl+click (Cmd-click for Macs) each subsequent stencil you wish to select.

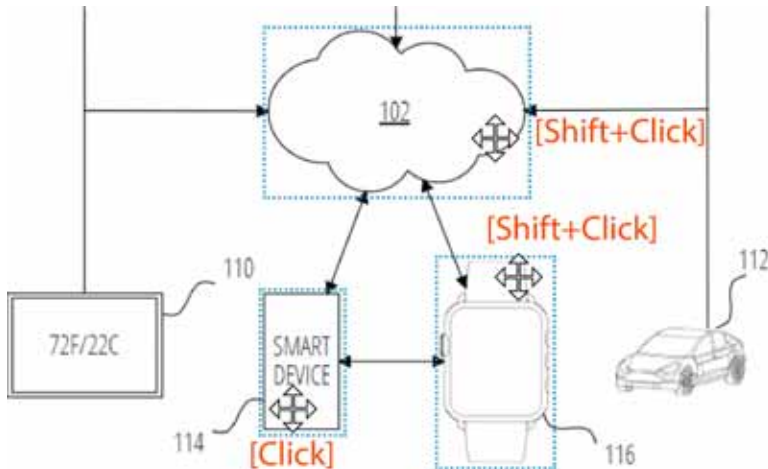

3. Your clicked stencils will be selected and a blue, dotted boundary box will be displayed around each to indicate your selection.

*Note that if a stencil has been locked to the canvas a solid gray boundary box will be displayed.*

## Click+Drag to Select Stencil(s)

1. Click a point on the drawing canvas.
2. Drag your mouse until the selection box overlaps at least a portion of the stencil(s) you wish to select.

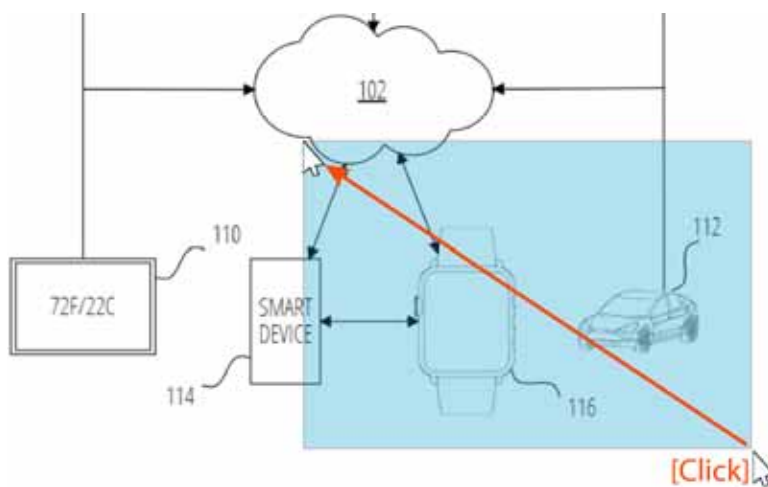

3. Release your mouse button.

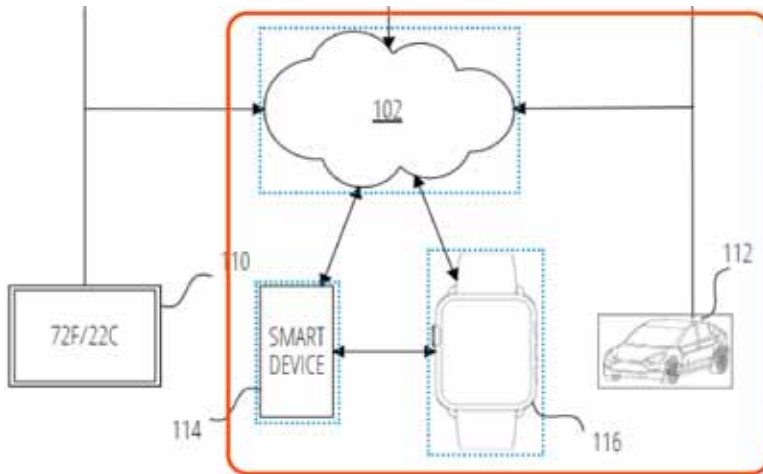

4. Your stencil(s) will be selected and a blue, dotted boundary box will be displayed around each to indicate your selection.

*Note that if a stencil has been locked to the canvas a solid gray boundary box will be displayed.*

## Select a Single Connector Line

1. Click your mouse cursor on the desired connector line.

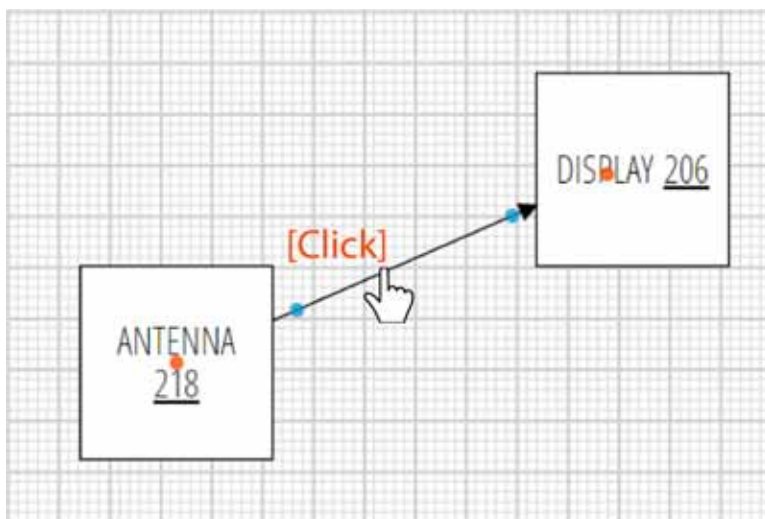

*Note that, unlike stencils, only one connector at a time can be selected.*

2. Blue control points for your connector will be displayed, and if your connector is anchored on one or both ends, the orange anchor points will also be displayed.

## Move Stencils Around the Drawing Canvas

### Drag and Drop Stencils

1. Select the stencil(s) you wish to move.
2. Click and drag your selection to the canvas location you desire.

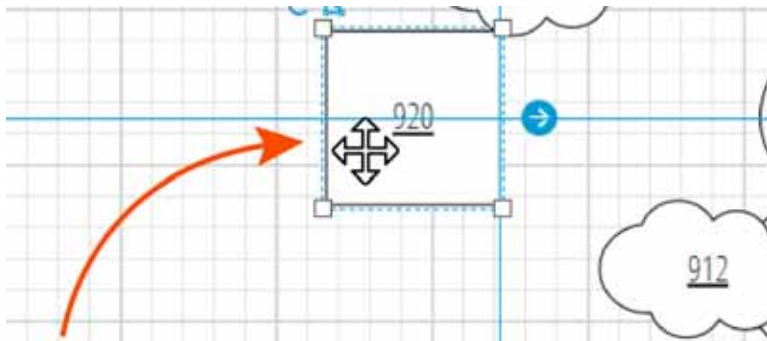

*For number+lead line stencils, click and drag the blue control point opposite from the number to move the entire stencil. Clicking and dragging the point near the number rotates the number around the opposite control point.*

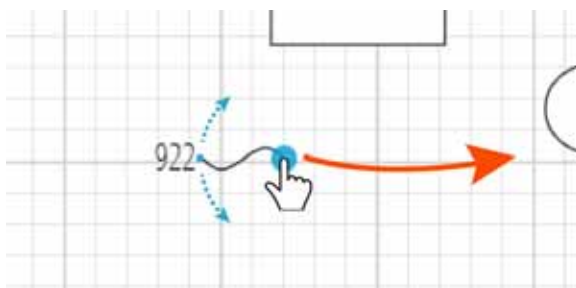

3. Drop your selection to place it at the desired location.

*Note that the selected stencil(s) will be moved in increments corresponding to the grid size. For more granular control, reduce the grid size or turn the grid off.*

## Move Stencils with Arrow Keys

1. Select the stencil(s) you wish to move.
2. Press the up, down, left, and right arrow keys on your keyboard to move your selection in those directions.

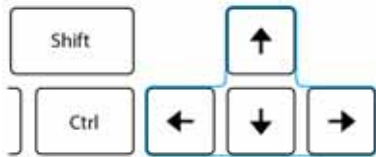

*Note that the selected stencil(s) will be moved in increments corresponding to the grid size. For more granular control, reduce the grid size or turn the grid off.*

3. Hold Shift and press the up, down, left, and right arrow keys on your keyboard to move your selection in those directions by a minimum increment, rather than the full grid increment.

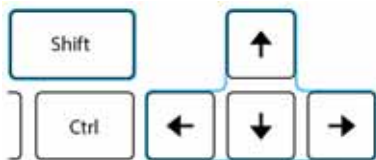

## Use Stencil Anchors to Move Connector Lines

1. Connect each end of a connector line to a stencil.

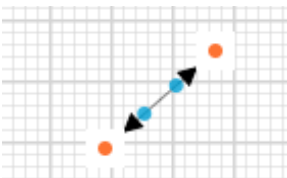

*If you do not want one or either of the stencils to be visible, you can remove the part number(s) and set the border(s) to be invisible. You can make them small (e.g., 5mm x 5mm) to reduce the space they take up.*

2. Select both of the connected stencils.
3. Use the methods above to move the anchor stencils, thus moving the connector line.

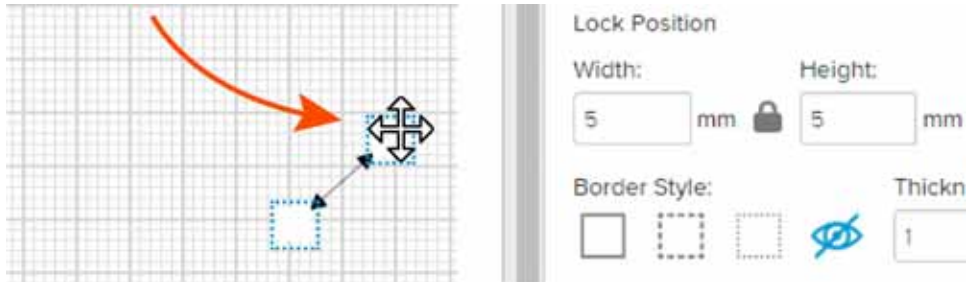

## Assign/Remove Part Data and Labels for a Figure Element

### Assign Part Data to a Stencil or Connector Line

1. Select or add the desired stencil or connector line on the Drawing Tool canvas.
2. Locate the part data and labeling fields in the Element Info controls in the toolbar or right-hand sidebar

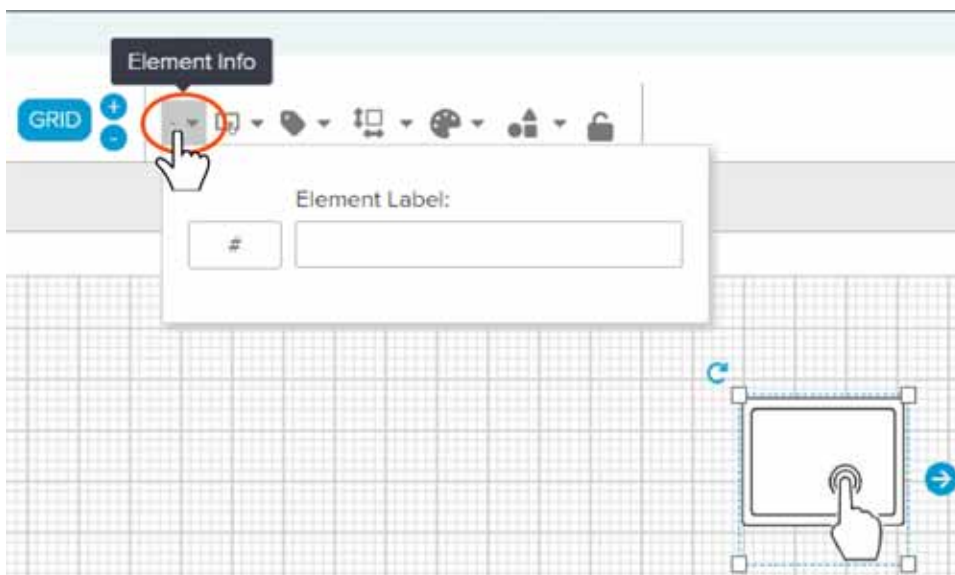

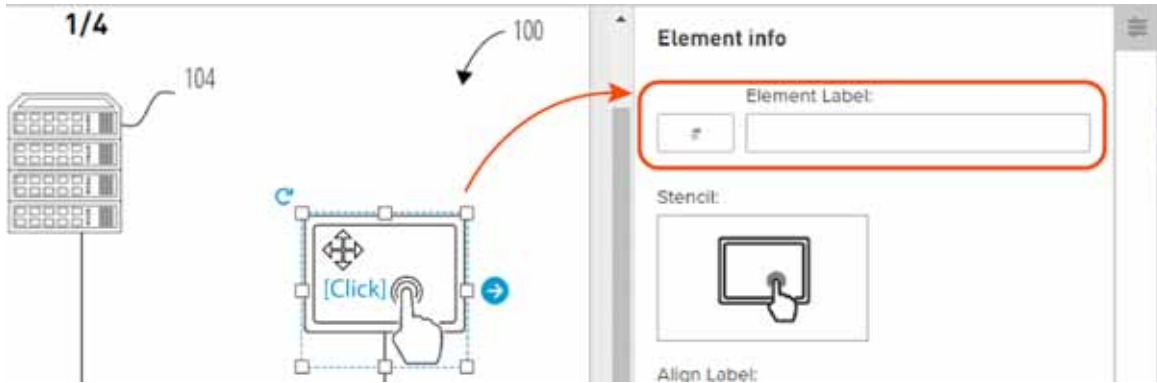

OR double-click the stencil to bring up on-canvas part data and labeling controls.



*Note that connector lines are not provided with an on-canvas part data interface, and must be modified in the right-hand sidebar.*

*Note also that connector lines may be numbered but will not display a text name or label unless the Show Label control is selected.*



3. If the element does not have a part number assigned, click the # to the left of the part name field and assign a new part number.

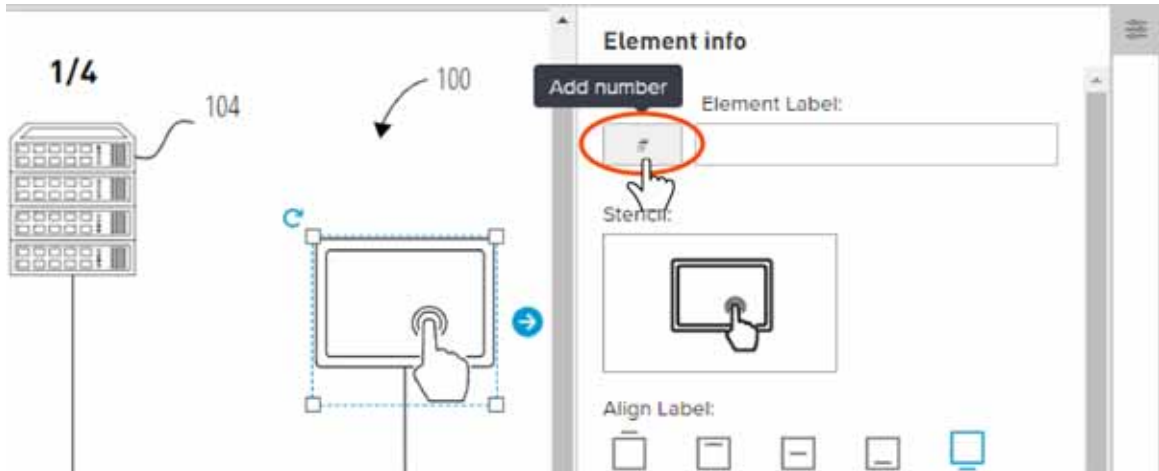

*Note that for simplicity the controls for this and the following steps are shown in the right-hand sidebar, but are available in the three locations described in Step 2.*

4. A new part will be created and assigned to the selected element.

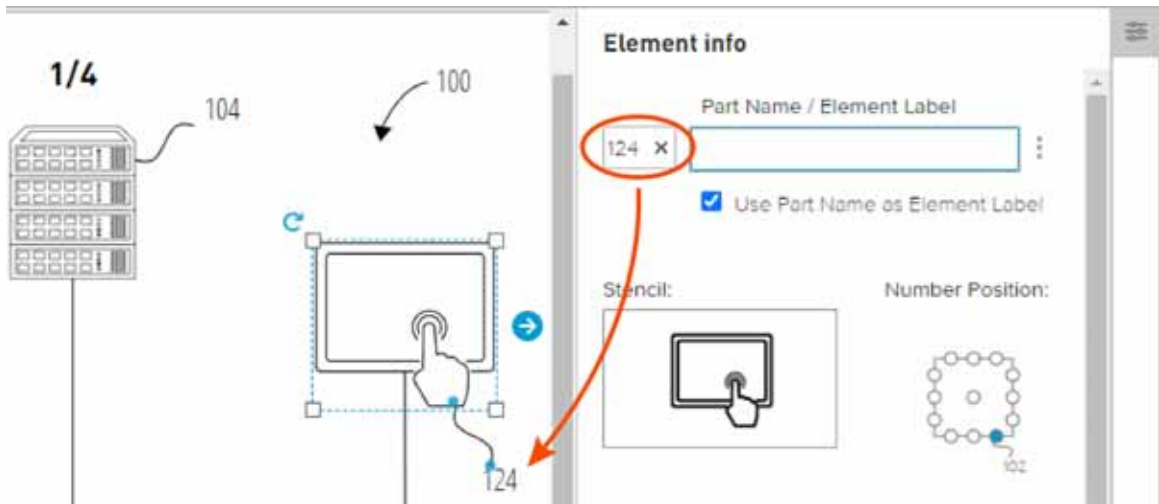

*To assign an existing part to the element, see [Change Part Data Assigned to a Stencil or connector line](#) below.*

*Note that once the element is associated with a part, the part number and name may also be modified in the [Parts Panel](#).*

5. If the element does not have a part name assigned, click the part name field and type in a part name.



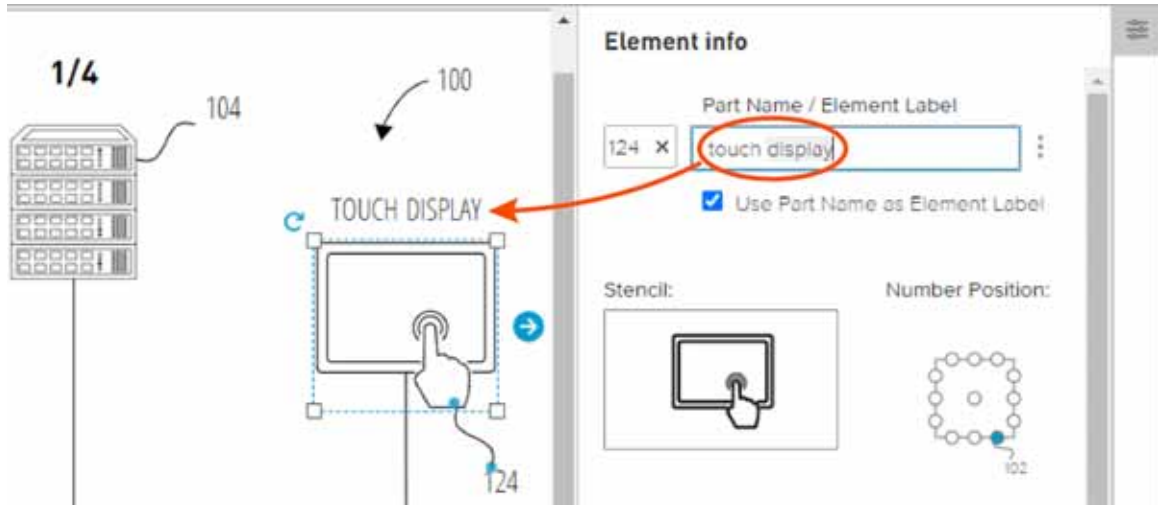

6. Further updates to this part data, either in the toolbar, the right-hand sidebar, the on-canvas editor, or the Parts Panel will be reflected in your on-canvas element.

## Apply an Independent Label to a Stencil or Connector Line

1. Select or double-click the desired stencil or connector line to access part data and labeling controls, as shown above.
2. Click to uncheck the Use Part Name as Element Label control.

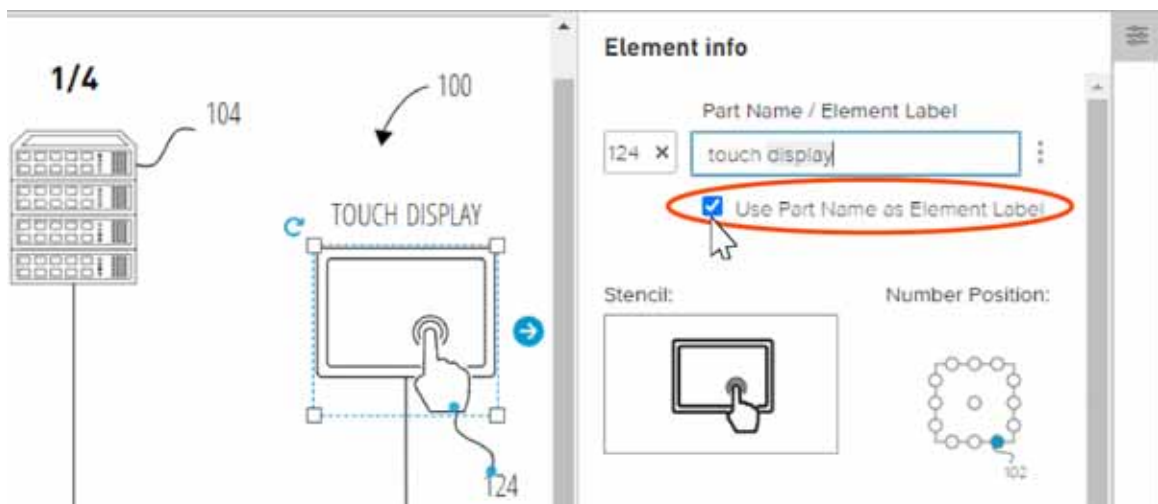

3. Delete the part name from the Element Label box.

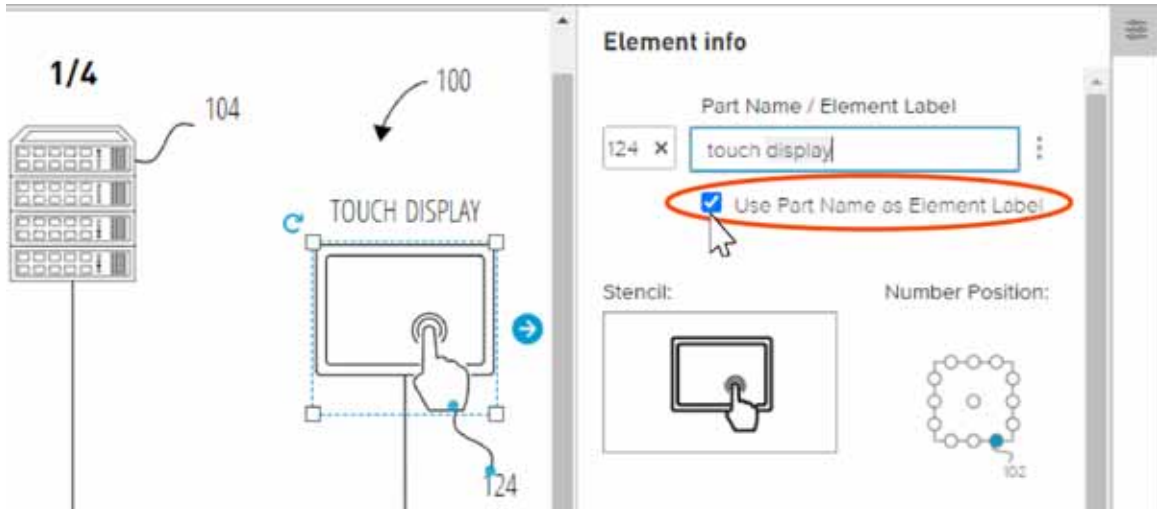

*At this point, you can leave the label field blank if you simply wish to not display the part name.*

4. Enter your desired label text in the Element Label field.

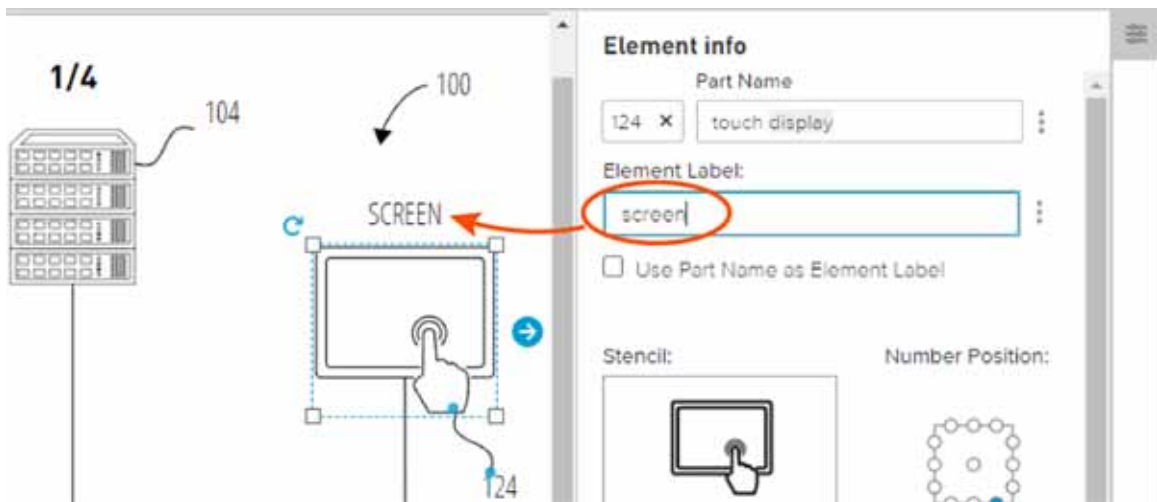

5. The element label will be used in the stencil or connector line on your canvas.

*Note that part references in your application will continue to include the part name, NOT the label.*

*Note that the label is applied only to the selected stencil or connector line. Other elements associated with the same part data will not be given this label unless manually updated as above.*

6. To return to using the part name instead of an independent label, click to re-check the Use Part Name as Element Label control.

## Remove Part Data Associated with a Stencil or Connector Line

1. Delete the part associated with the stencil or connector line from the Parts Panel

OR select or double-click the desired stencil or connector line to access part data and labeling controls, as shown above.

2. Click the x next to the part number.

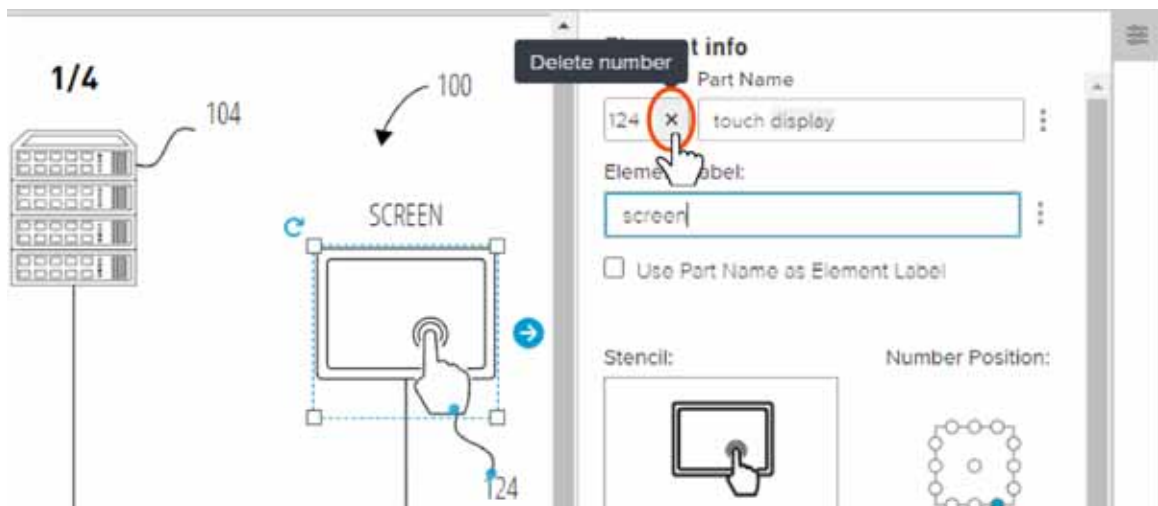

3. The part number will no longer be associated with or appear on your on-canvas element.

*Part name data will now appear as the element label, and this text can be deleted from the Element Label field to remove it from your on-canvas element.*

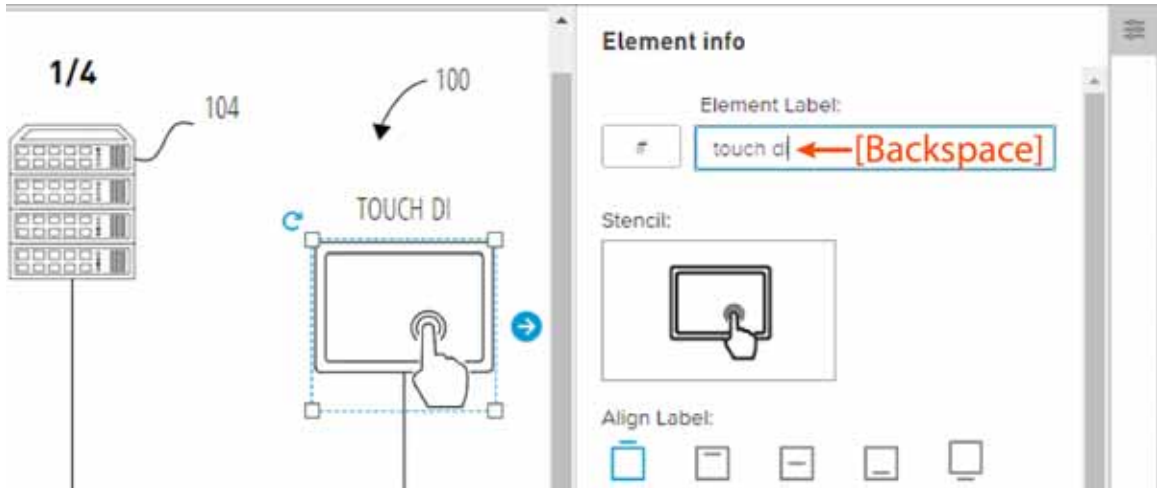

## Change Part Data Assigned to a Stencil or Connector Line

1. Select or double-click the desired stencil or connector line to access part data and labeling controls, as shown above.
2. Click the number field to assign a new part number.

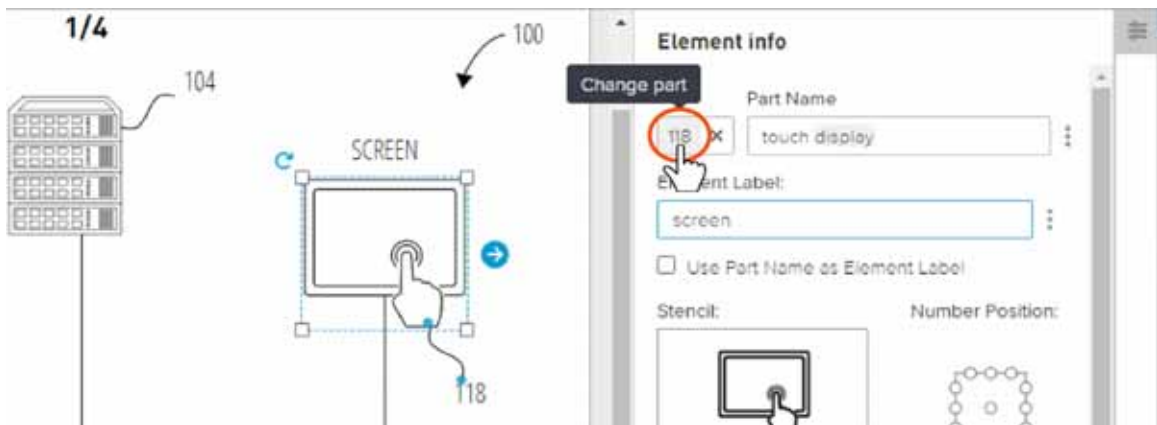

3. Select the desired part from the list provided.

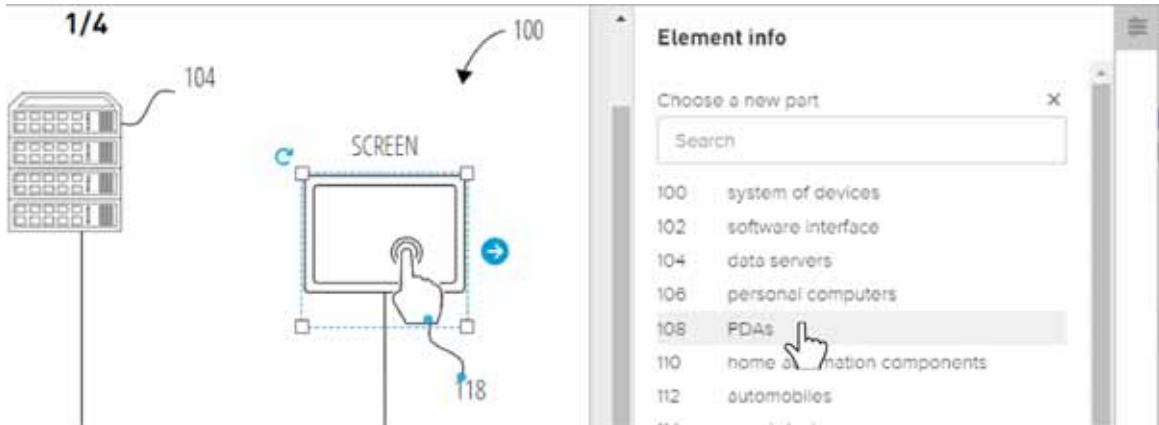

4. Your on-canvas element will be associated with data for the selected part.

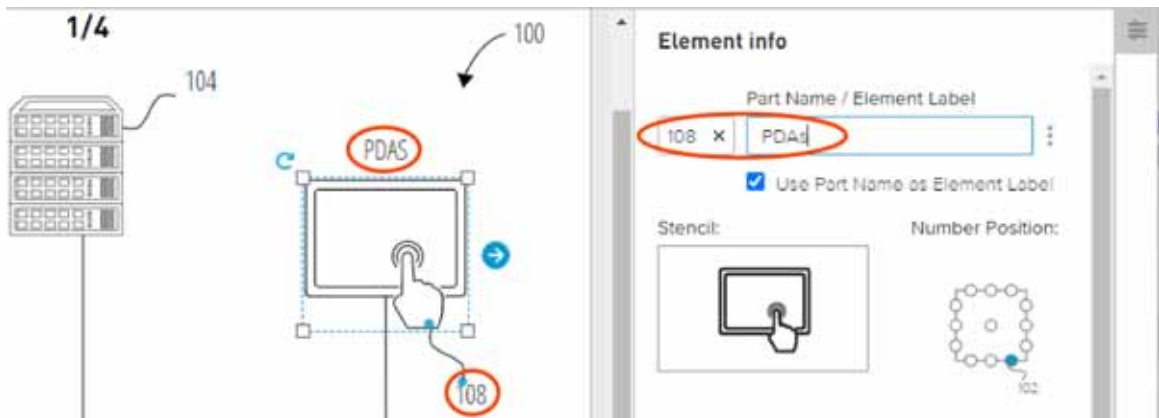

## Adjust Stencil Part Number Placement

1. Select the stencil(s) you wish to adjust part number placement for.
2. Locate the Layout controls in the toolbar or right-hand sidebar.

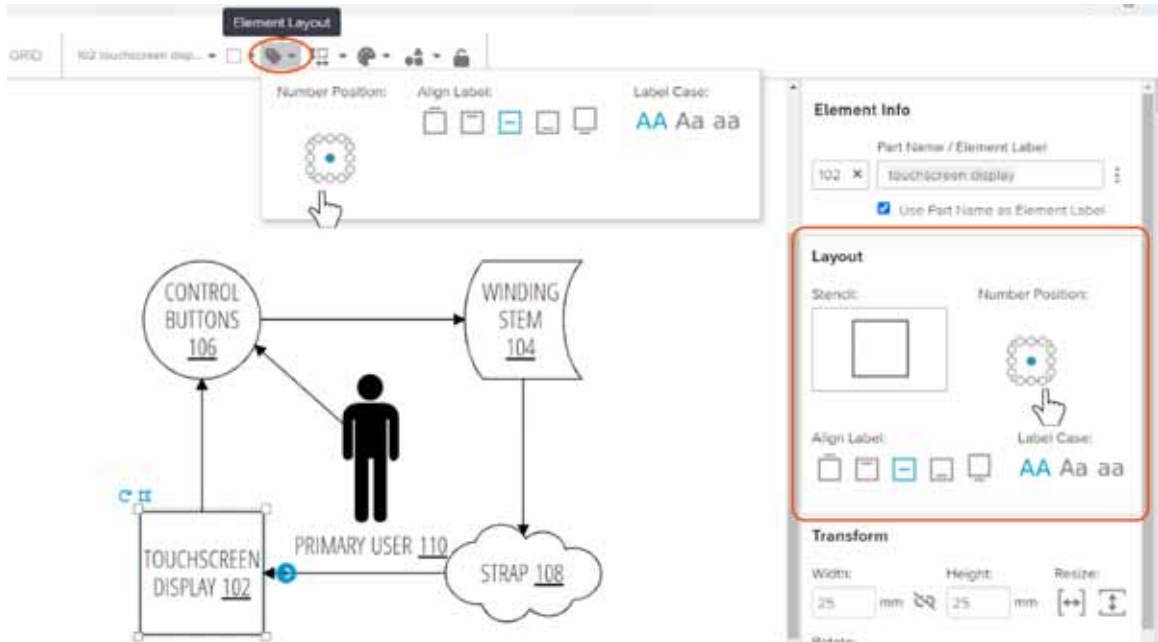

3. Locate the Number Position control in the right-hand sidebar.

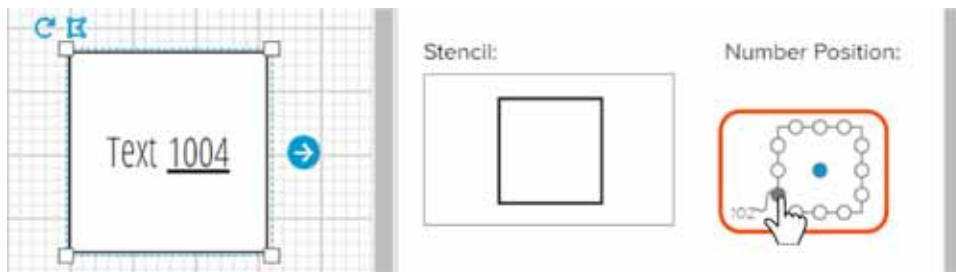

*Note that when the position option within the boundary of the stencil is selected, the number follows text alignment settings: Above, Top, Center, Bottom, and Below.*

4. Select the position you want the number to take.

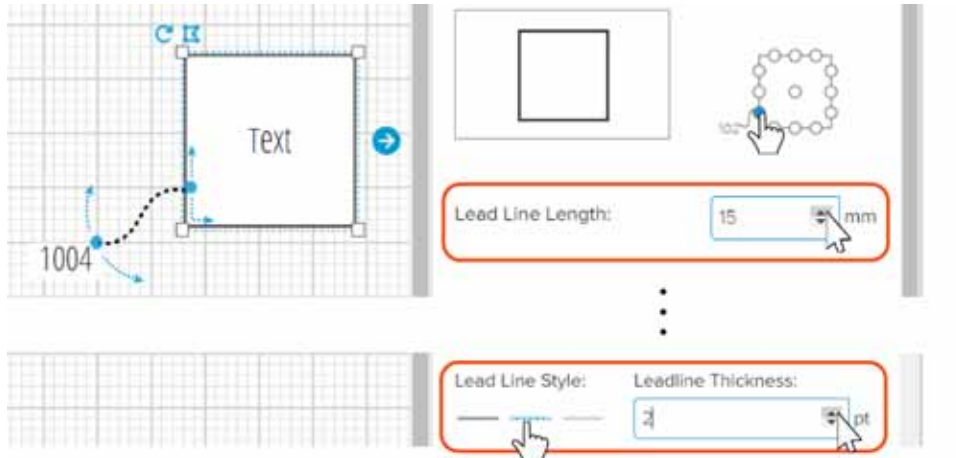

5. With a lead line position selected, use the Lead Line Length control among the Layout controls to shorten or lengthen the lead line.
6. To change the style and thickness of the leadline, locate and use the Lead Line Style and Lead Line Thickness controls among the Style controls in the toolbar or right-hand sidebar.
7. If you wish to rotate the number around its stencil connection point, click and drag the blue control point at the number end of the lead line.
8. If you wish to reposition the number at another point on the stencil border, drag and drop the blue control point at the stencil end of the lead line.

## Adjust Text Case and Alignment

1. Select the stencil or connector line you wish to adjust text case and alignment for.

*Only text case can be adjusted for labeled connector lines.*

2. Locate the Layout controls in the toolbar or right-hand sidebar.

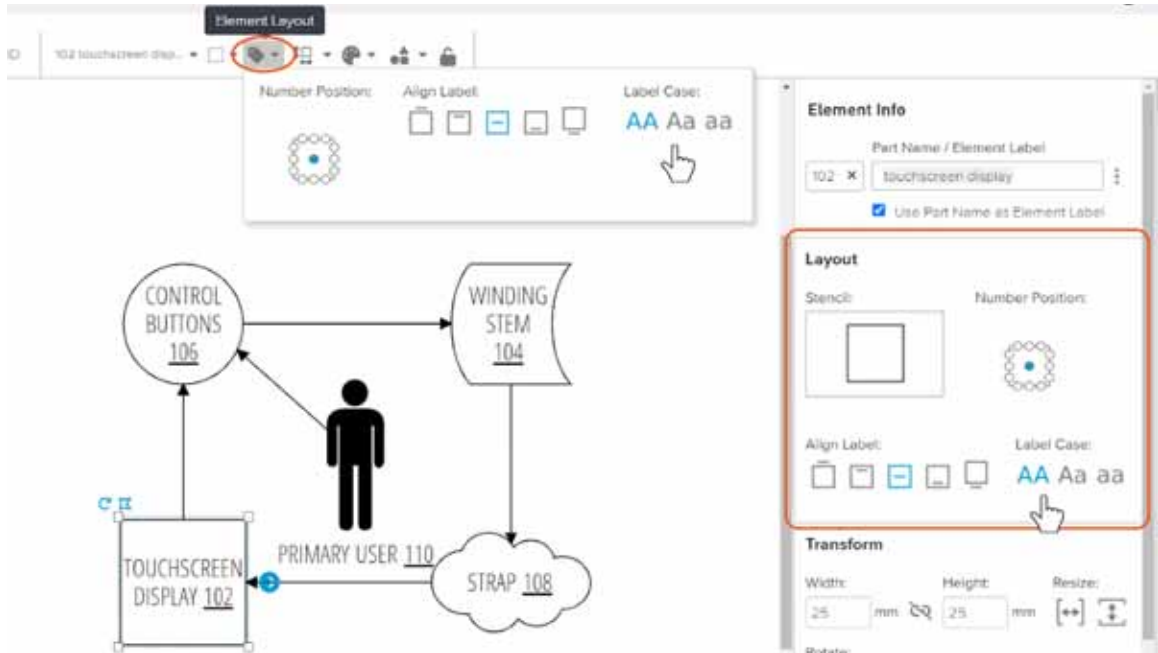

3. Select the desired case option from the Label Case controls.

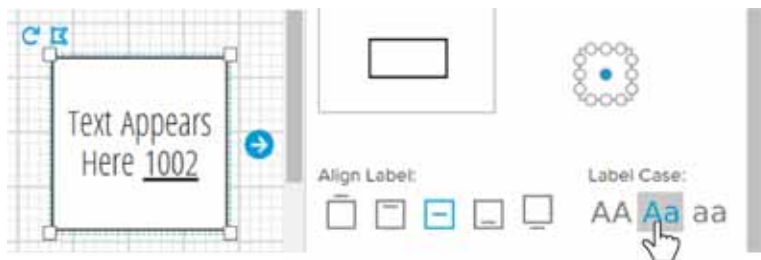

*AA displays text in ALL CAPS.*

*Aa displays text in Title Case, i.e., the first letter of each word is capitalized.*

*aa displays text using upper and lower case as you've typed it.*

4. Select the desired text alignment option from the Align Label controls.





Stencil text may be aligned above the stencil boundary.  
Stencil text may be top-aligned within the stencil boundary.  
Stencil text may be vertically centered within the stencil boundary.  
Stencil text may be bottom-aligned within the stencil boundary.  
Stencil text may be aligned below the stencil boundary.  
At this time, stencil text is always horizontally centered with respect to the stencil.

5. To apply subscript or superscript style to text as needed, select the desired text within the Element Info text entry field in the toolbar, right-hand sidebar, parts panel, or popover controls available when the stencil is double-clicked.
6. Use the scripting controls presented to adjust selected text.

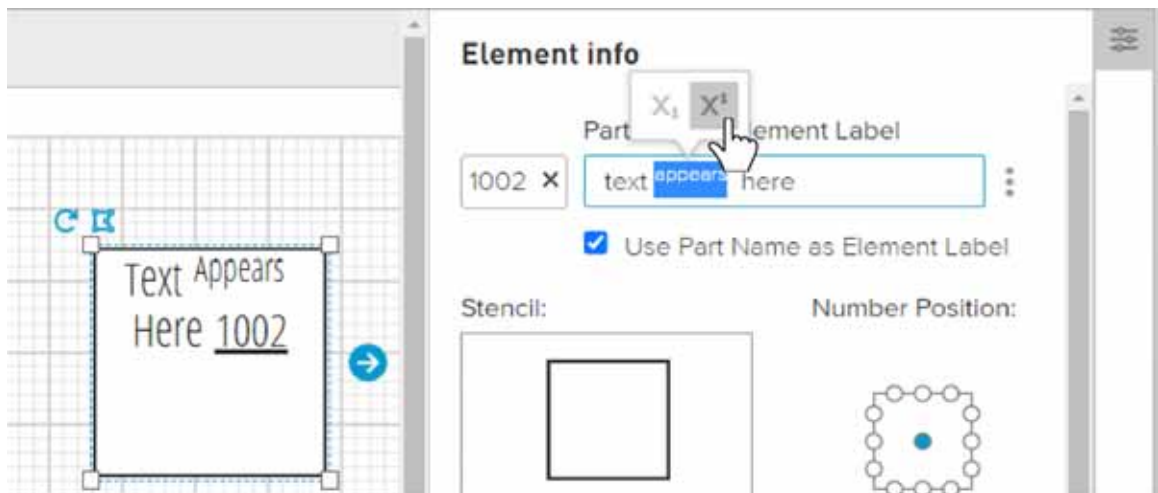

## Change Stencil to a Different Stencil Type

1. Select the desired stencil(s) and click the Stencil control in the toolbar or the right-hand sidebar.

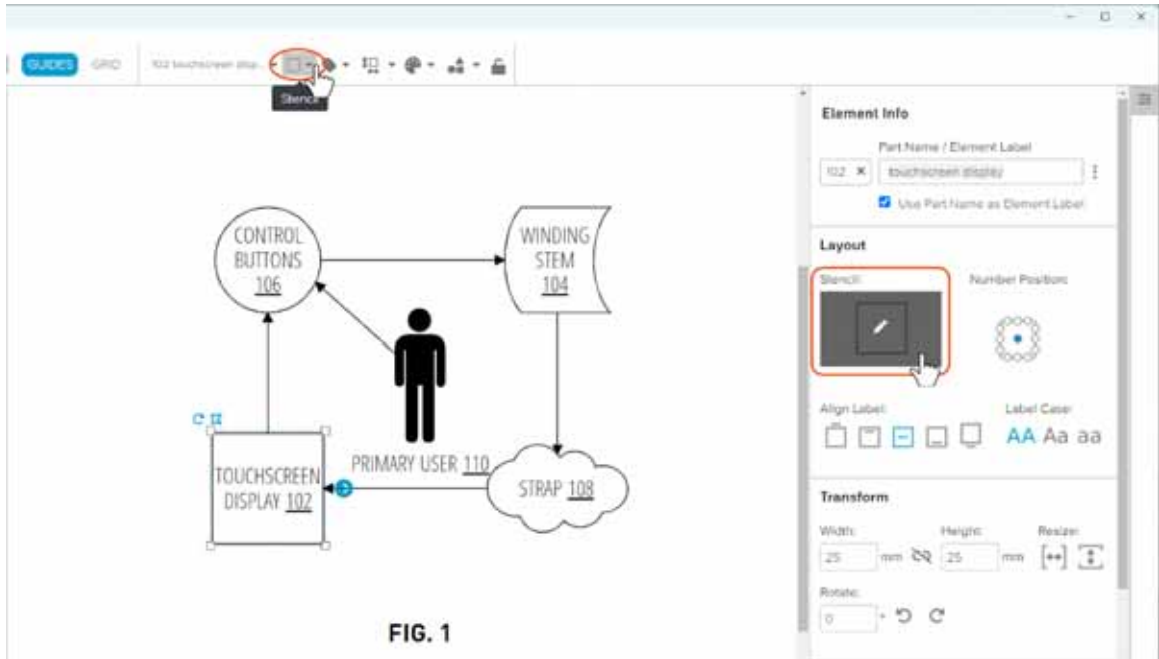

2. Click the desired stencil option.

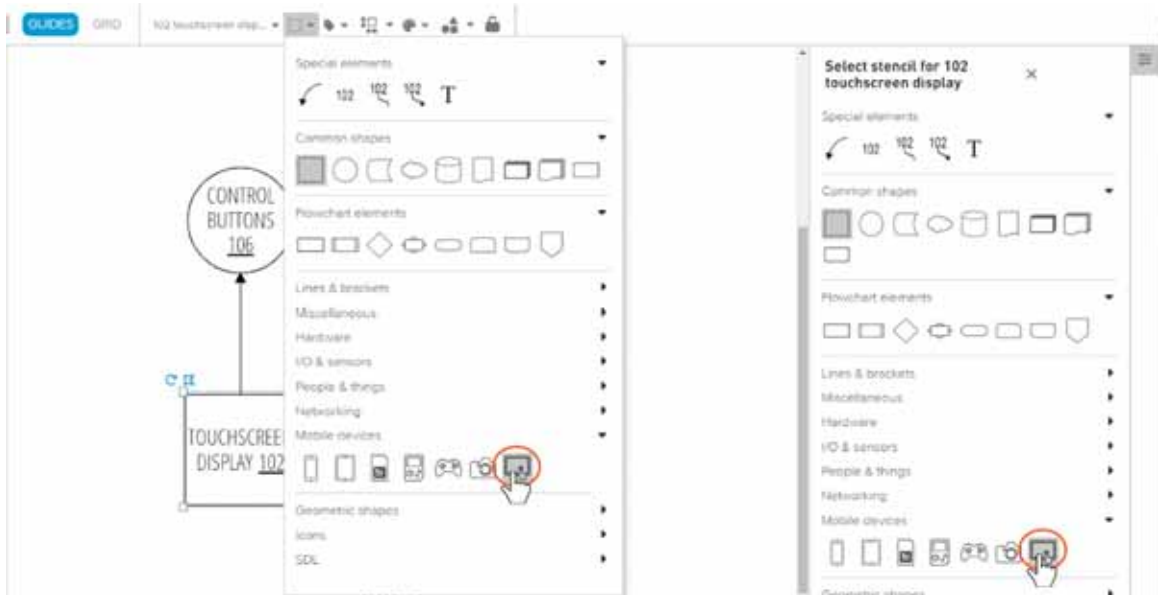

3. The selected stencil(s) will be updated while maintaining all labeling and style properties.

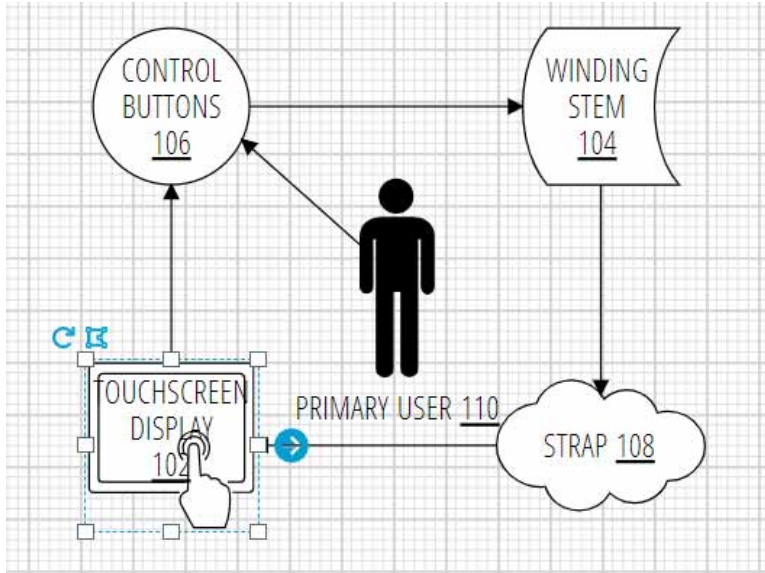

## Modify a Stencil's Shape

1. Select the stencil you wish to modify.
2. Click the edit control that appears to the upper-left of the selected stencil.

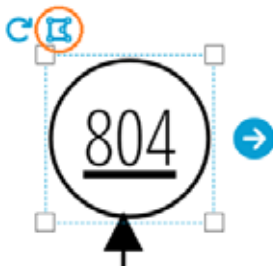

3. Controls will be displayed for editing vertices (red dots), curvature (blue dots), and sides (line segments) of the stencil.

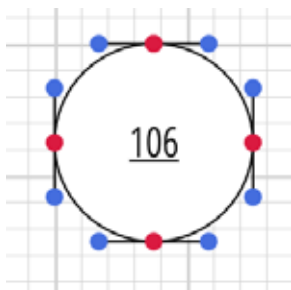

- Click and drag a red dot to move a stencil vertex.

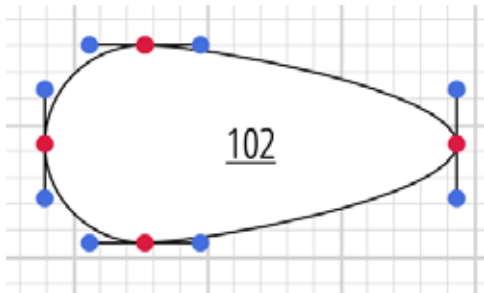

- Click and drag a blue dot to adjust the curvature around a vertex.

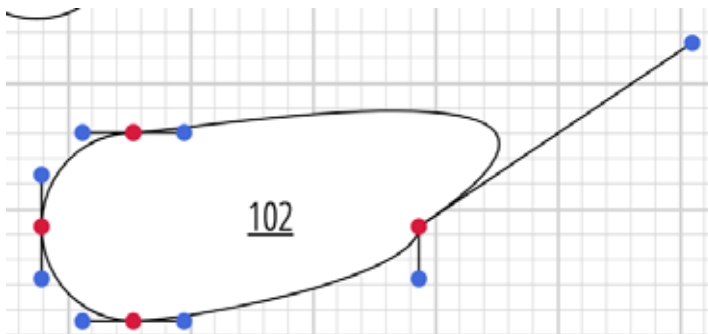

- Shift+Click a line segment to convert a straight line to a curve or vice versa.

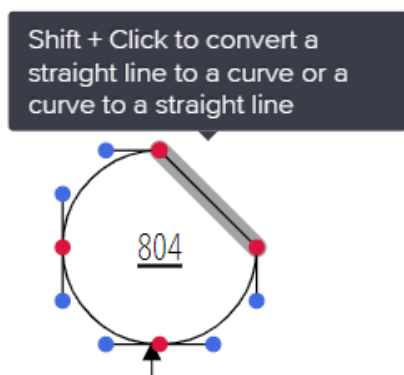

- Click and drag a line segment to move that side of the stencil.

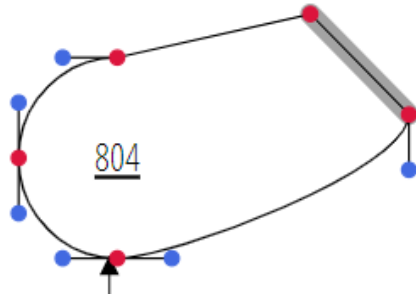

8. Double-click on any line segment to add a new red dot (vertex).

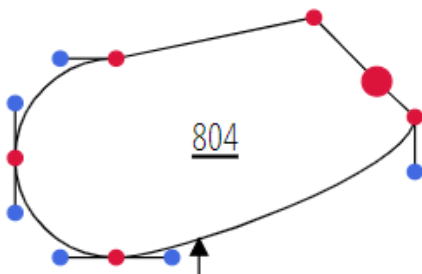

9. Double-click a red dot to remove that vertex.

10. When you're finished, click anywhere else on the canvas to deactivate stencil editing.

## Import a Drawing Stencil

1. Open the Drawing Tool and create or navigate to a desired figure.
2. Locate your desired stencil image (.svg, .jpg, or .png) file in your operating system file explorer and drag it onto your drawing canvas.

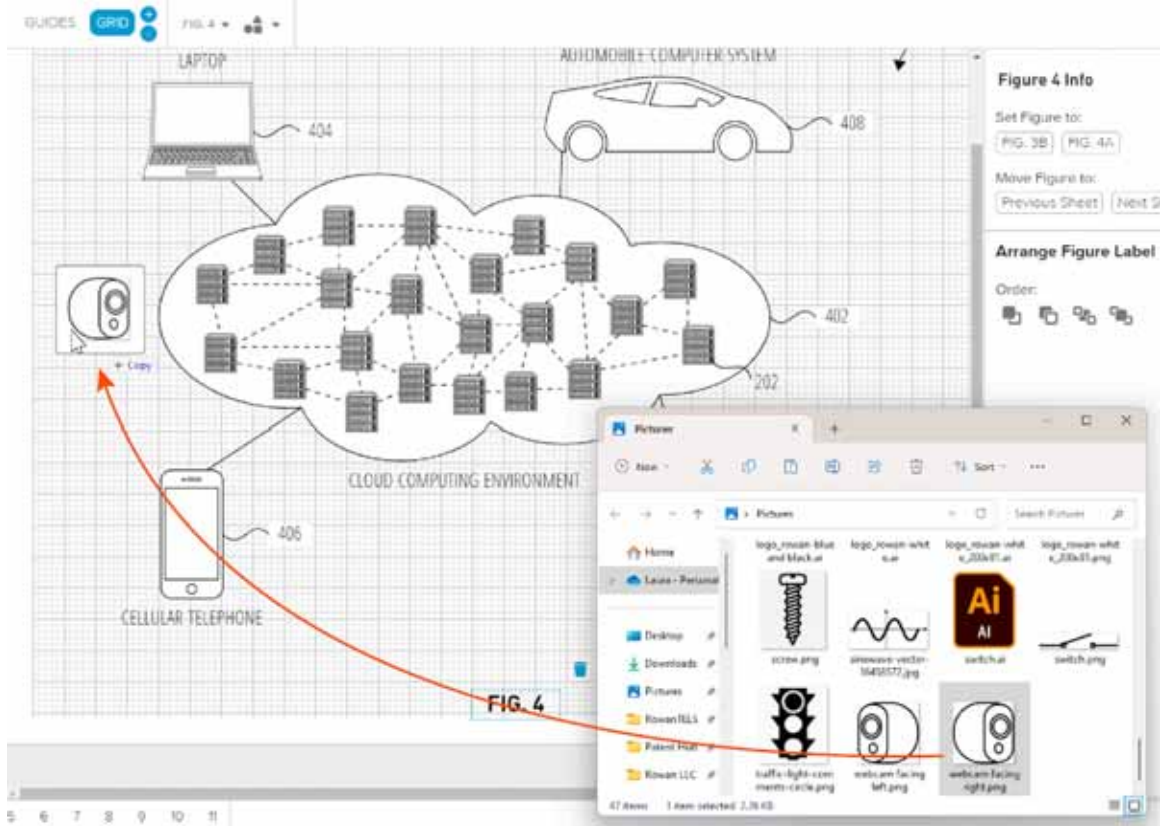

3. Alternately, select the Image Stencil (JPG, PNG, SVG) option from the Import dropdown in the toolbar or Drawing menu.

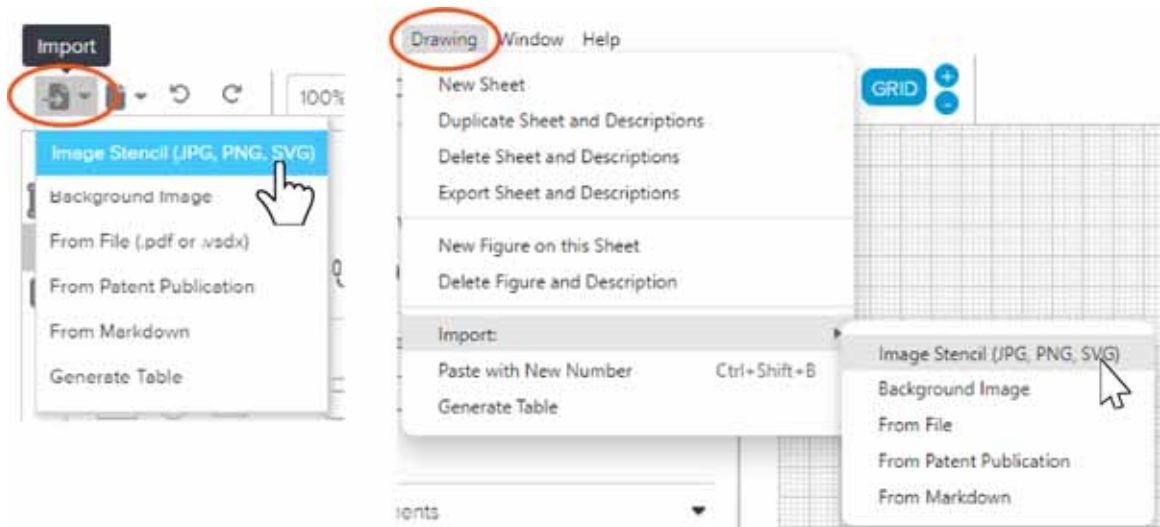

OR drag and drop the Image Import stencil from the Special Elements group in the Stencils panel in the Drawing Tool left-hand sidebar onto the drawing canvas.

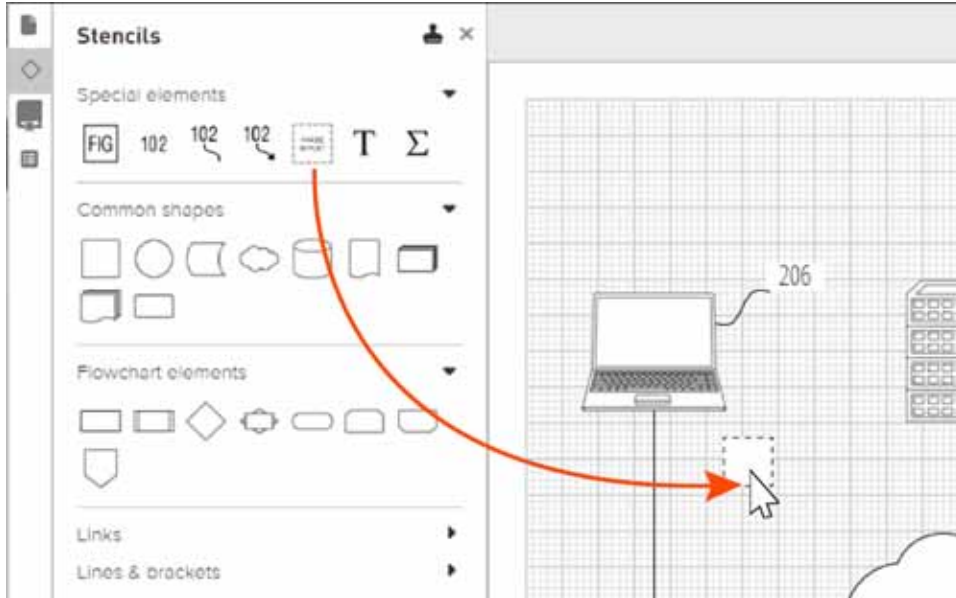

AND use the resulting dialog to drag and drop or browse to the desired image.

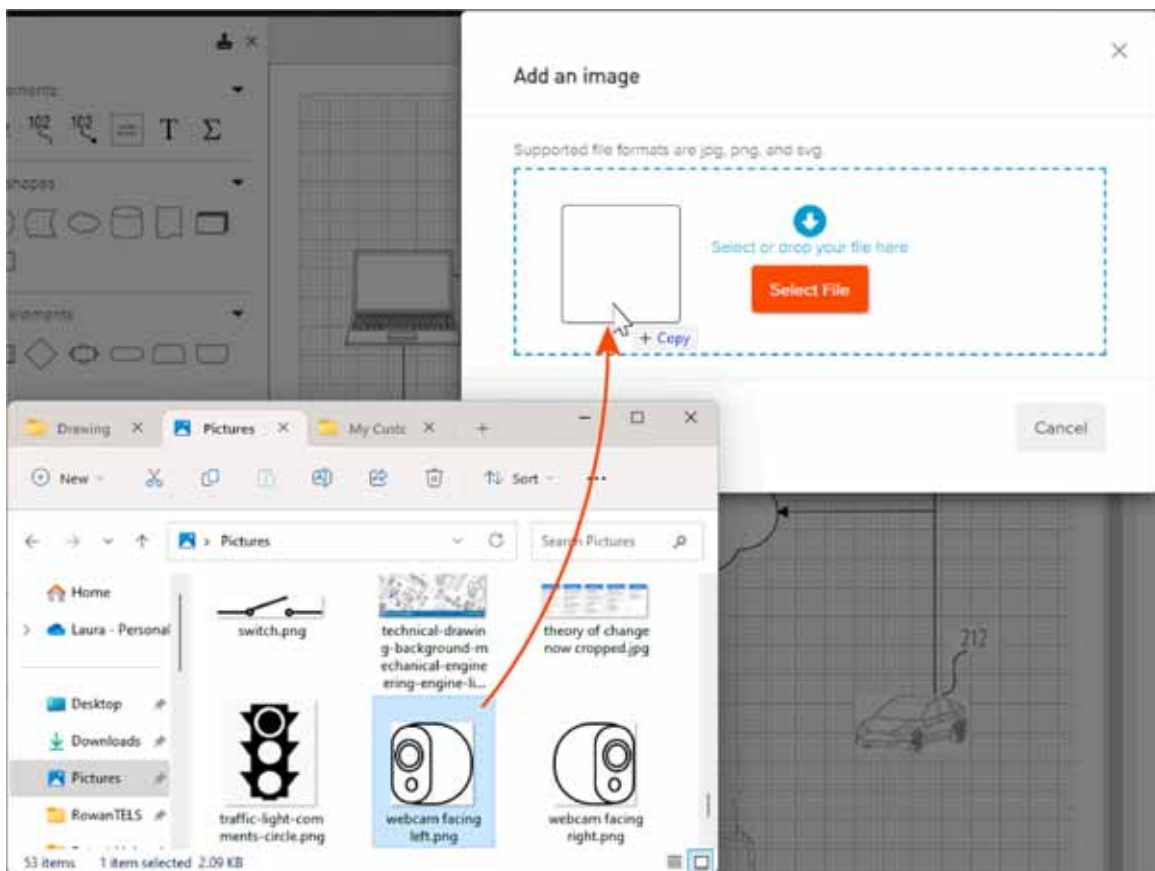

4. Your image will be inserted as a numbered element, and can be named, copied, pasted, connected, resized, etc. as any other stencil.

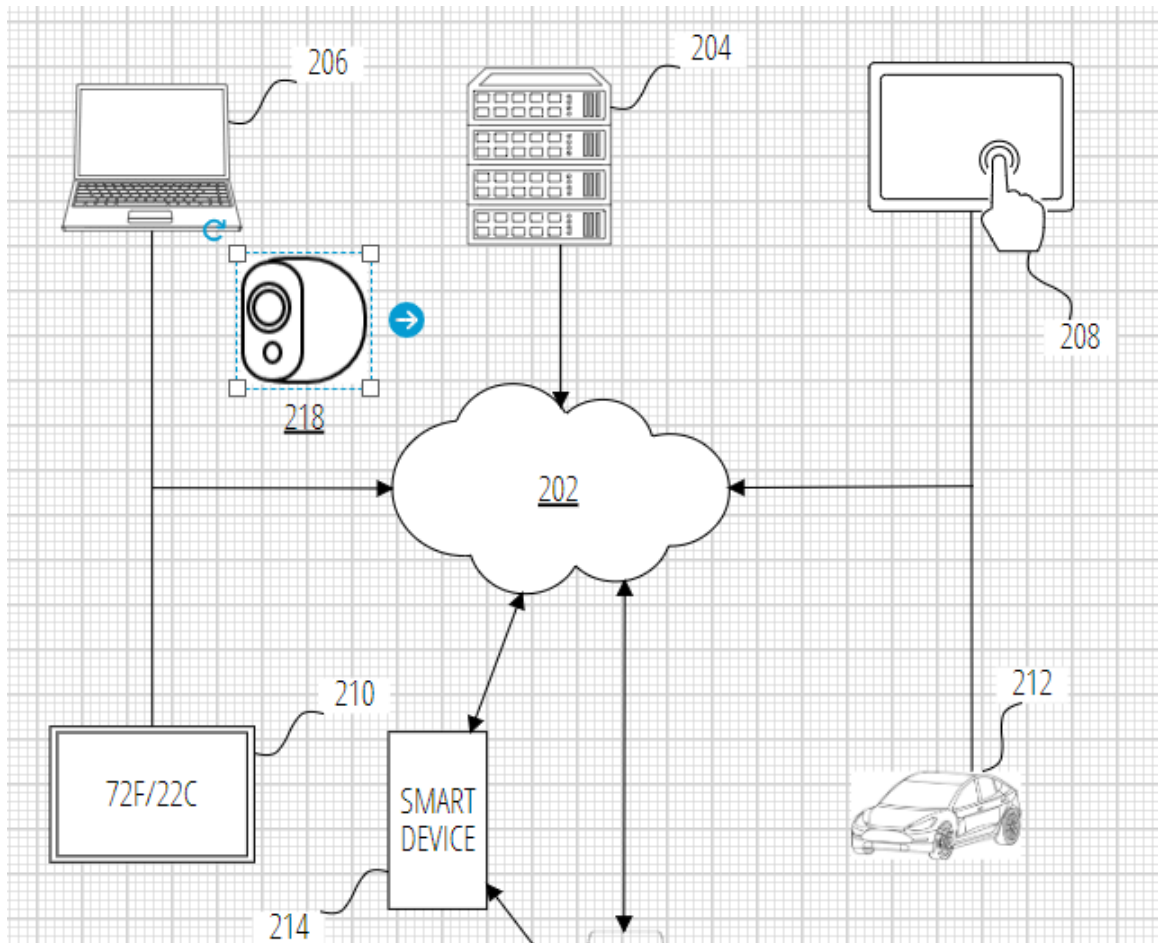

## Adjust Stencil Styles

1. Select the stencil(s) you wish to adjust styles for.
2. Locate the Style options in the toolbar or the right-hand sidebar.



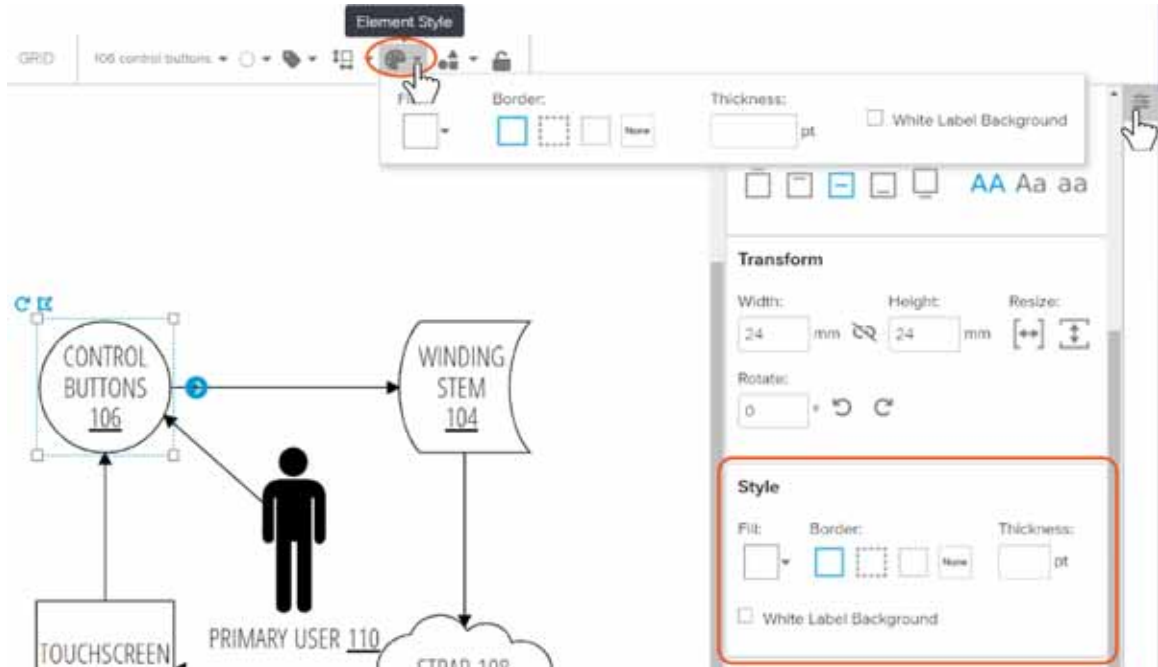

3. Select the desired stencil fill using the Fill dropdown control.

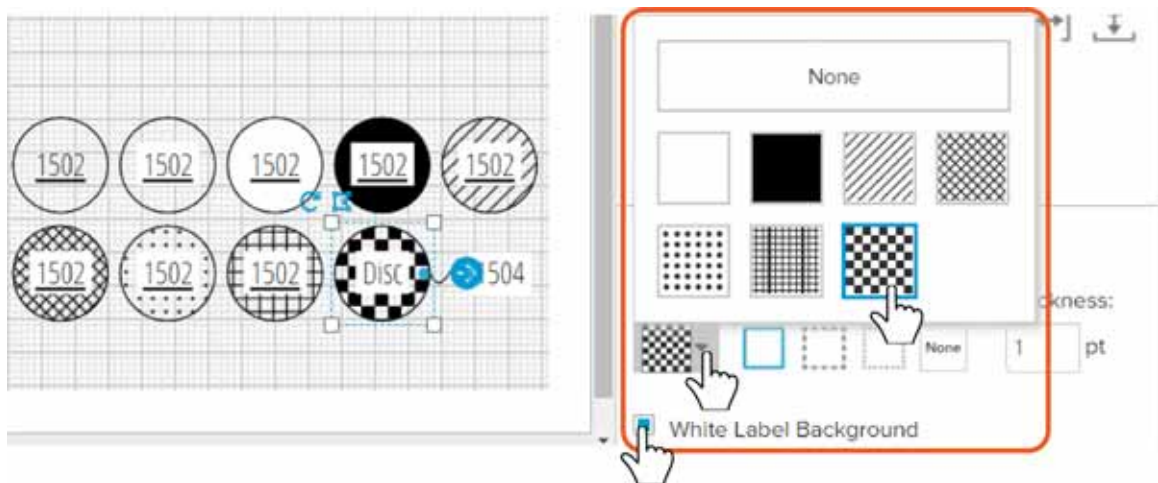

*A white label background can be selected where fills impact readability for text and numbering.*

4. Use the Border controls to give the selected stencil(s) a solid, dashed, dotted, or invisible border.



5. Use the Thickness field to change the border thickness by either typing a number or clicking the up/down arrows.

## Resize Stencils

### Drag to Resize

1. Select the stencil(s) you wish to resize.
2. If you wish to maintain the stencil's proportions, locate and click the aspect ratio lock in the Transform controls in the toolbar or right-hand sidebar.

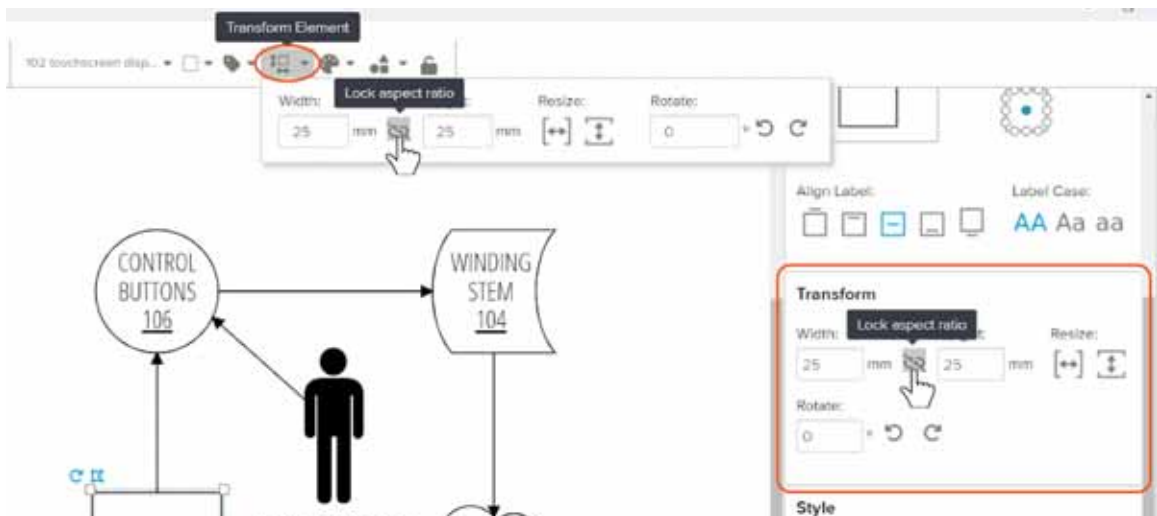

3. Click and drag any of the stencil's resize handles (white squares on each edge and at the corners).

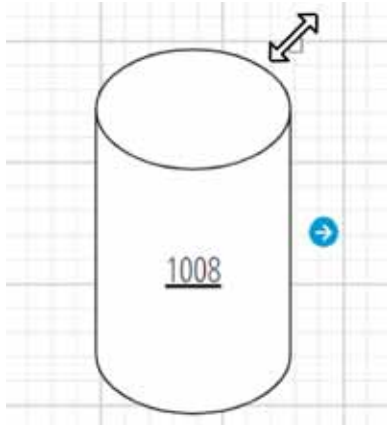

4. Drop the handle when your stencil is the size you desire.

*Note that this method will resize the stencil in increments related to the grid size. For more granular control, decrease the grid size or use the dimensional controls as described below.*

## Resize with Dimension Controls

1. Select the stencil(s) you wish to resize.
2. If you wish to maintain the stencil's proportions, click the aspect ratio lock as described above.
3. Locate the width and height controls in the toolbar or right-hand sidebar.

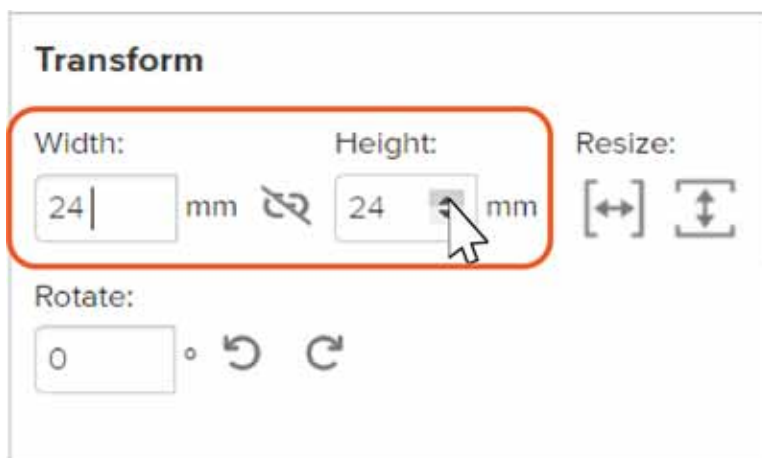

4. Type the desired dimensions or click the up and down arrows in the width and height control fields.

## Resize to Fit Text

1. Select the stencil you wish to resize to fit its label text.
2. Locate resize to fit controls in the Transform controls in the toolbar right-hand sidebar.



3. Click the Resize Horizontally to Fit control to adjust stencil width.
4. Click the Resize Vertically to Fit control to adjust stencil height.

## Rotate Stencils and Stencil Text

1. Select the stencil(s) you wish to rotate.
2. To freely rotate your selected stencil on the canvas, locate, click, and drag the Rotate control to the upper-left of your stencil.

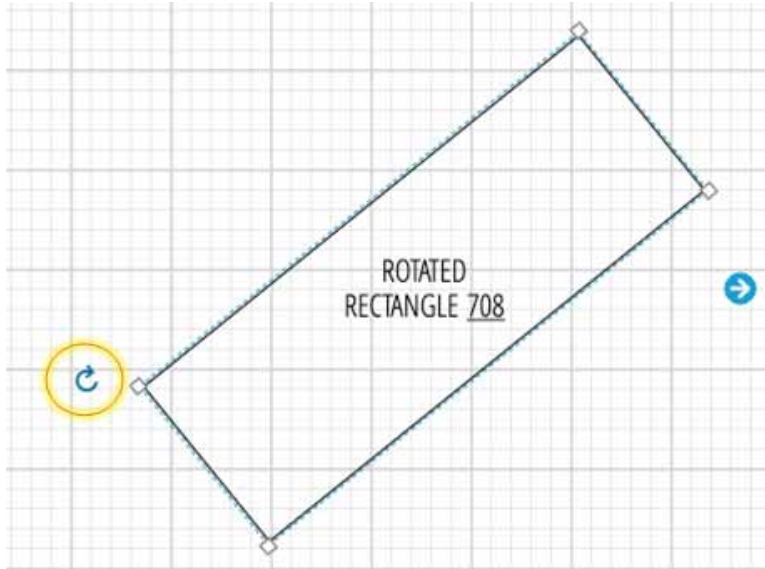

3. For more stencil rotation options, locate the Transform controls in the toolbar or the right-hand sidebar.

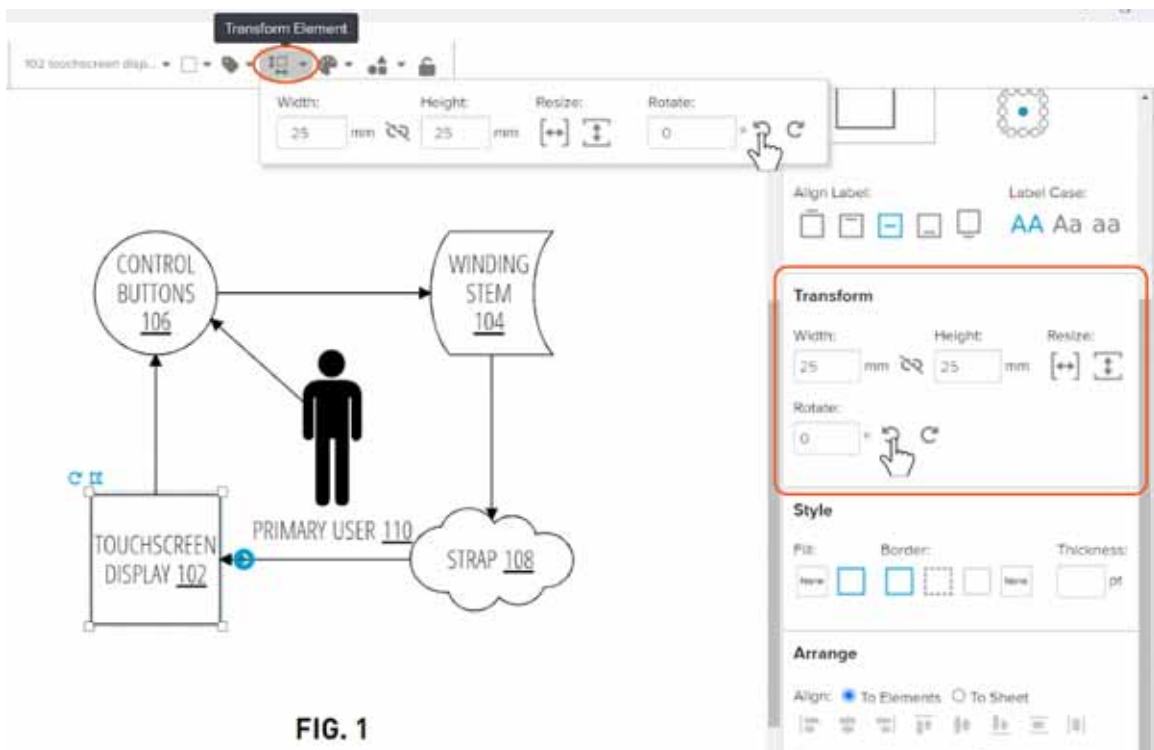

4. To quickly rotate your stencil(s) clockwise or counterclockwise in right-angle increments, locate and click the Rotate 90° control arrows in the right-hand sidebar.

Rotate:

350 ° ↶ ↷

5. To rotate your stencil(s) a specific number of degrees, type or use the up and down arrows to adjust the Rotate field.
6. To rotate stencil text as the stencil rotates, click the text rotation control to the right of the other rotation controls.

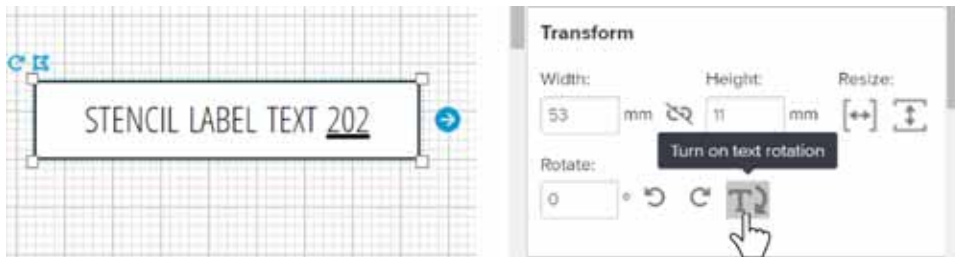

7. You will receive a dismissible message to confirm that you want to turn this attribute on. Click Enable Text Rotation to proceed.

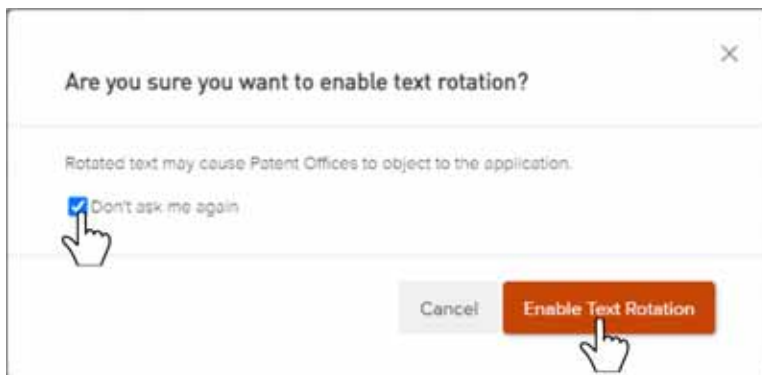

*Click the checkbox provided to turn off this confirmation message.*

8. When you rotate the stencil, the text will also rotate as long as this attribute is turned on.



*Clicking the text rotation control again will cause the text to return to 0° rotation.*

## Align and Distribute Stencils

1. Select the element(s) you wish to align and/or distribute.
2. Locate the Arrange controls in the toolbar or right-hand sidebar.

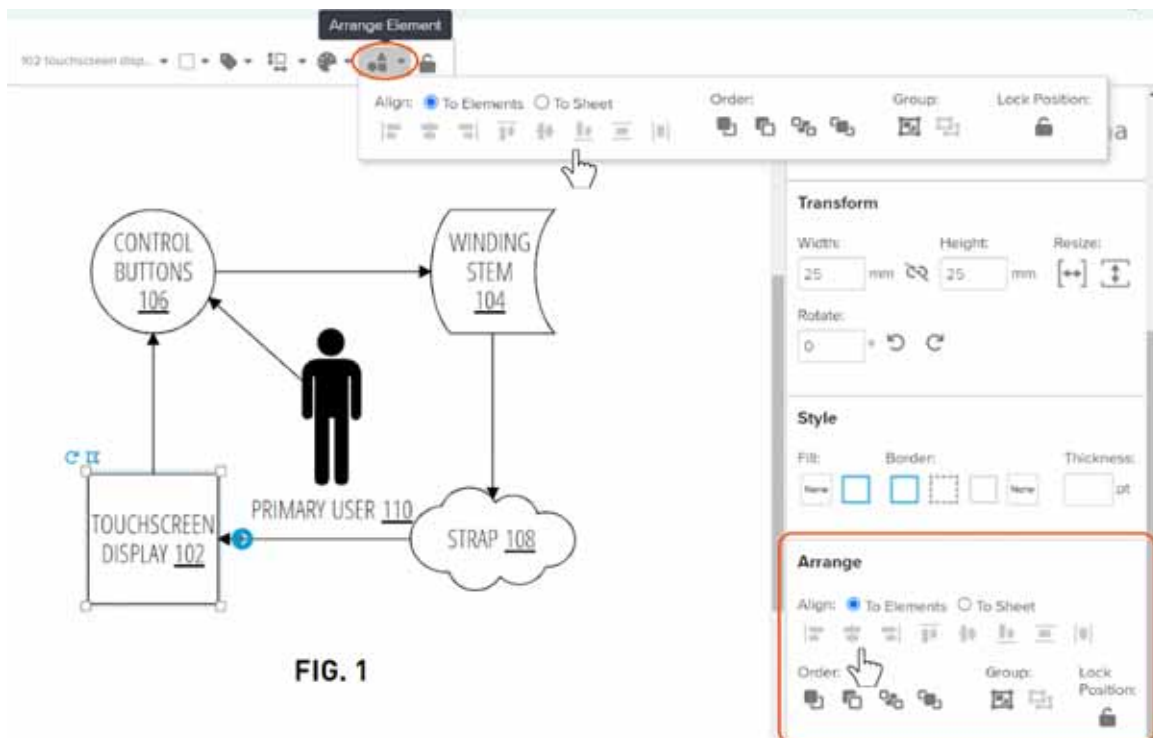

**FIG. 1**

3. Select whether you wish to align the elements relative to each other or absolutely with respect to the figure sheet.

## Arrange

Align:  To Elements  To Sheet



*Note that individual elements can only be aligned to the sheet.*

4. Click the alignment and distribution control you need for the layout you desire.

*Left alignment will align all elements with the left side of the leftmost element among the group, or to the left edge of the sheet. Right, top, and bottom alignment will perform similarly with regard to their respective parameters.*

*Center alignment will find the vertical centerline among the outermost vertical edges among all selected elements and center all elements to that line, or will vertically center the element(s) on the sheet. Middle alignment will perform similarly with regard to horizontal parameters.*

*Distributing vertically will maintain the top-most and bottom-most stencils of the selected set in their present location and space the rest evenly between those two, or will evenly space stencils across the sheet from top edge to bottom edge. Distributing horizontally will perform similarly with left-most and right-most stencils or from left sheet edge to right sheet edge.*

*For best results, place stencils roughly in their desired locations before distributing them.*

## Change Overlap Order of Elements on the Drawing Canvas

1. Select the element(s) you wish to bring forward or send backward in the canvas overlap order.
2. Locate the Order controls among the Arrange controls in the toolbar or right-hand



sidebar.

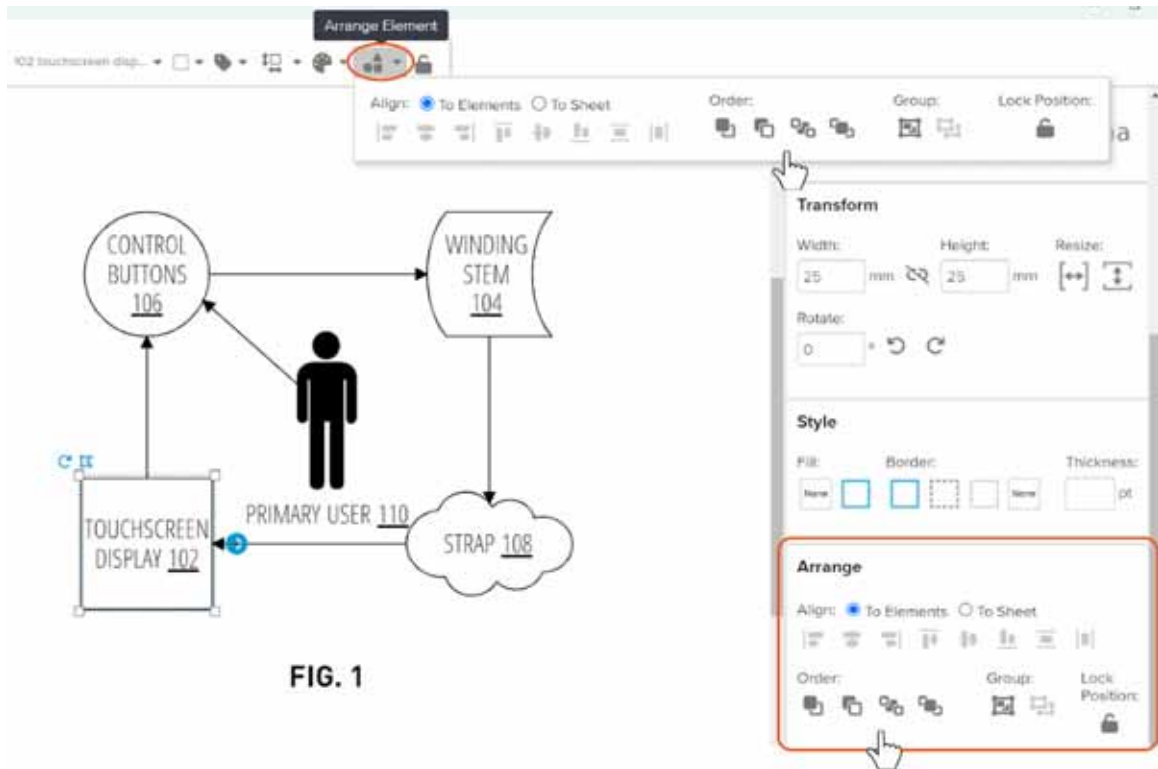

FIG. 1

3. Select the desired operation from the available options.

*Forward brings selection one step forward in the current on-canvas order.*

*Front brings selection to the front of the current on-canvas order.*

*Backward sends selection one step backward in the current on-canvas order.*

*Back sends selection to the back of the current on-canvas order.*

*Elements are by default ordered on the canvas based on the order in which they are placed or created, with the exception that copied elements are placed directly in front of their source elements.*

## Group Stencils

1. Select the stencils you wish to group.
2. Locate the Group control among the Arrange controls in the toolbar or right-hand sidebar.

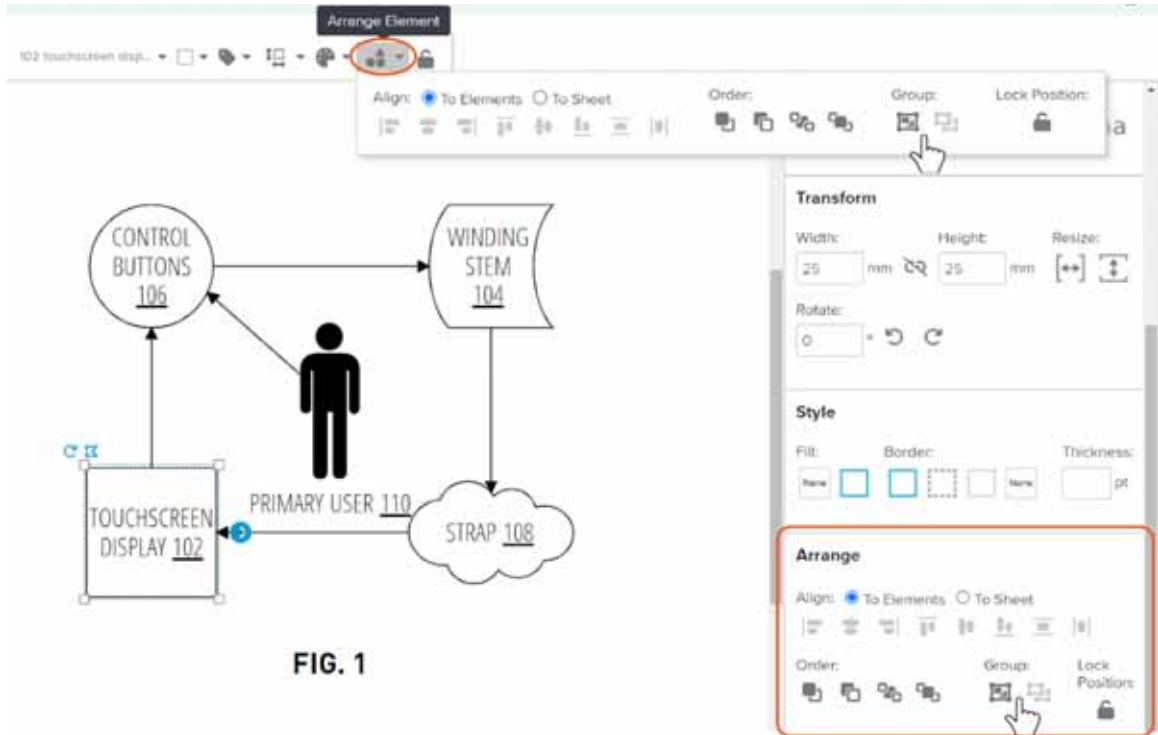
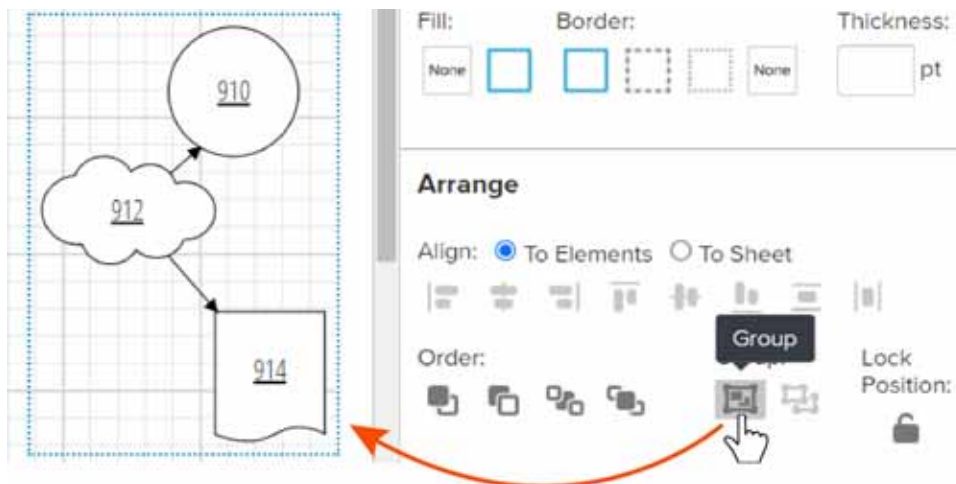
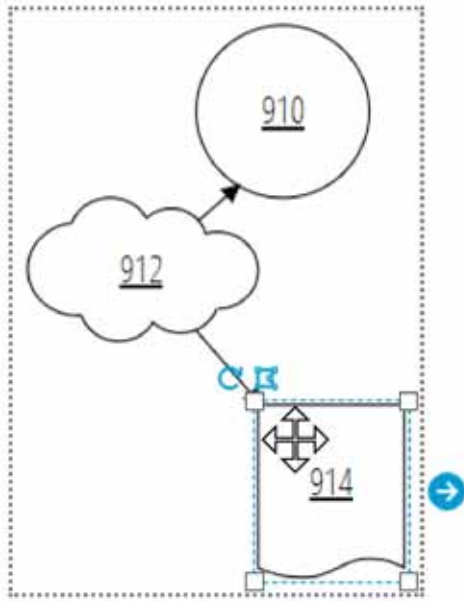

FIG. 1

3. Click the Group control in the toolbar or right-hand sidebar.



4. To select a single stencil within a group, click any stencil in the group to select the group, then click to select the desired stencil.



You can also click then Shift+click to select multiple stencils within the group.

5. To ungroup the grouped stencils, click the Ungroup control in the toolbar or right-hand sidebar.

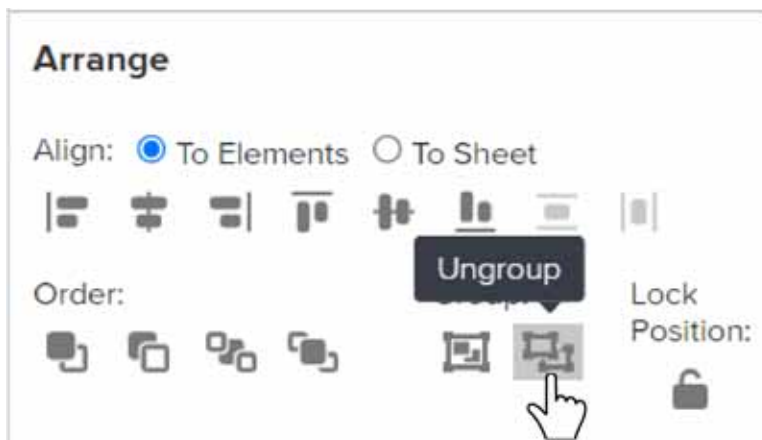

## Adjust Connector Line Styles

1. Select the connector you wish to adjust styles for.
2. Locate the Style options in the toolbar or right-hand sidebar.

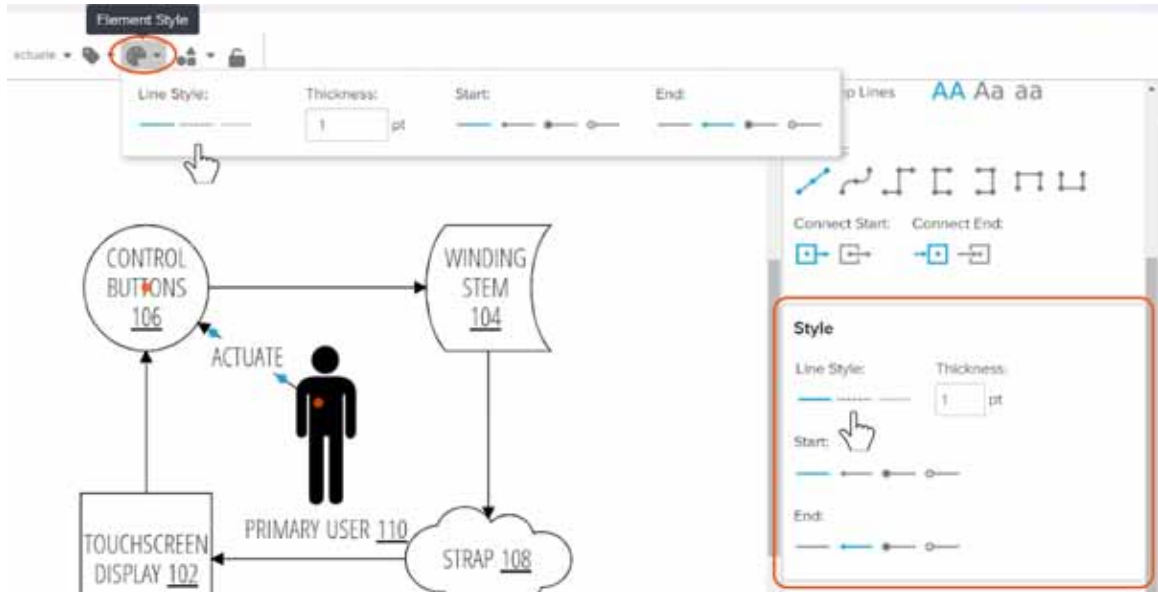

3. Use the Line Style controls to make the selected connector line a solid, dashed, or dotted line.



4. Use the Thickness field to change the line thickness by either typing a number or clicking the up/down arrows.



5. Use the Start and End controls to independently change the connector line start and end point features to none, arrow, filled circle, or hollow circle.

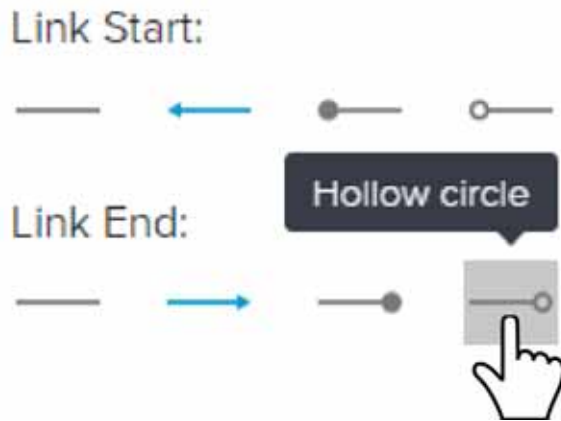

## Adjust Connector Line Routing

### Relocate End Points and Add Inflection Points (Blue)

1. Select the desired connector line on the canvas. Anchor (orange) and control (blue) points will be visible when a connector line is selected.

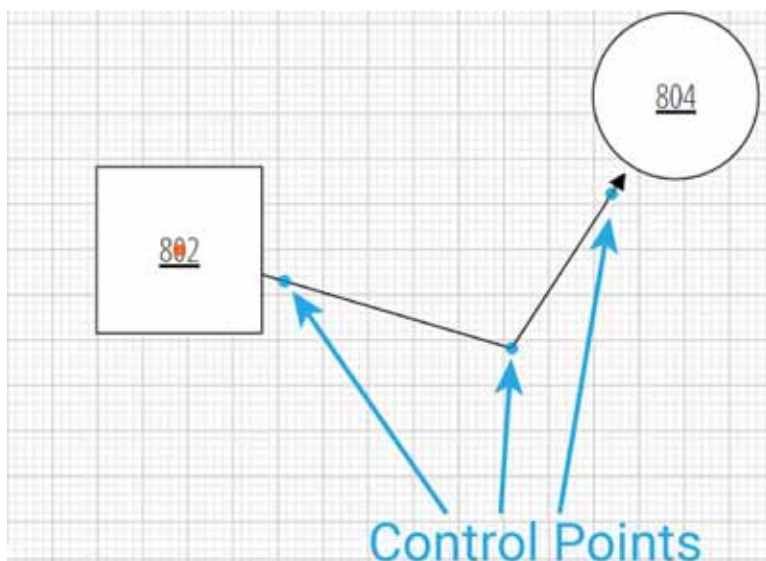

2. Click and drag a blue end or start control point away from a connected stencil to disconnect the connector line from the stencil
3. Click a selected connector line to add an additional inflection control point. Multiple inflection control points can be added to a connector line.

4. Click and drag inflection control points to adjust connector line routing.
5. Double-click added inflection control points to delete them.

## Relocate Anchor Points (Orange)

1. Select the desired connector line on the canvas. Anchor (orange) and control (blue) points will be visible when a connector line is selected.

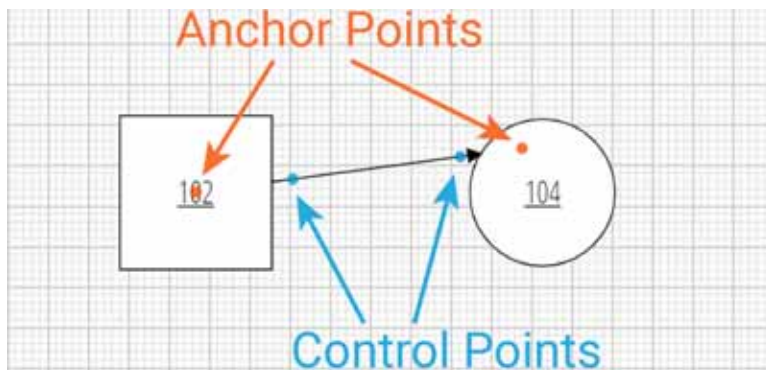

2. Click and drag an anchor point within its stencil to change the connection location to that stencil.
3. Double-click an anchor point to set its connection location to the exact center of the stencil.

## Adjust Routing Style

1. Select the connector line you wish to adjust routing style for.
2. Locate the Layout controls in the toolbar or right-hand sidebar.

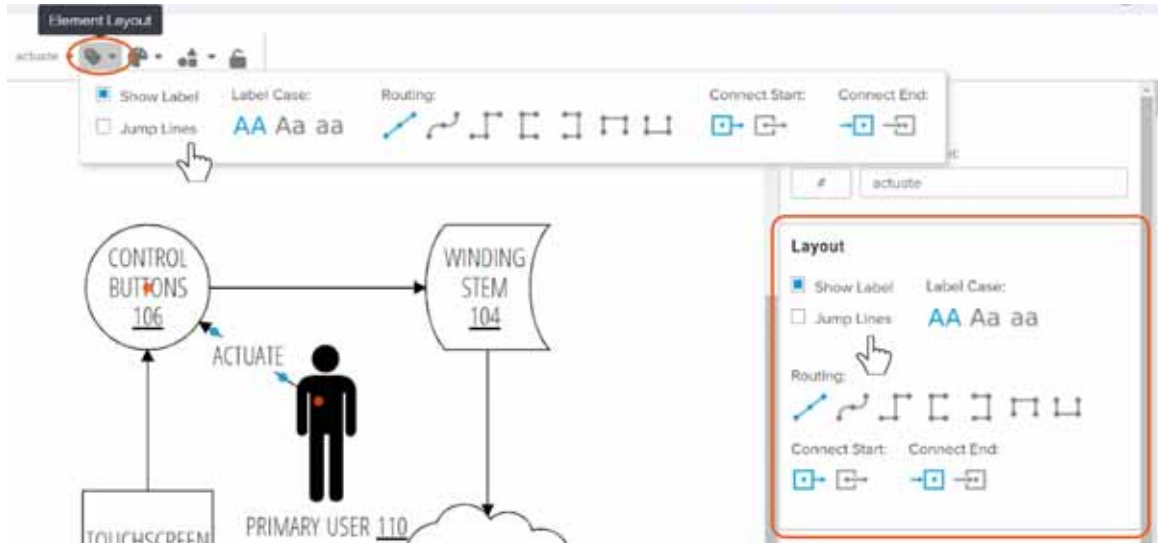

3. Check the Jump Lines control to set a selected connector line to include a jump at intersections with other connector lines.

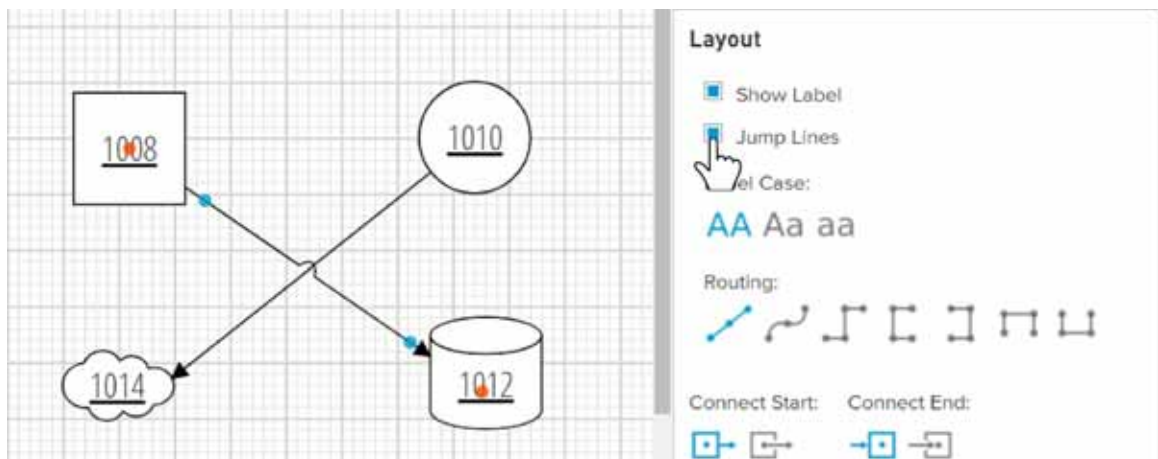

4. Use the Routing controls to determine whether connector lines are straight, curved, or take right-angled paths between the two stencils they connect.

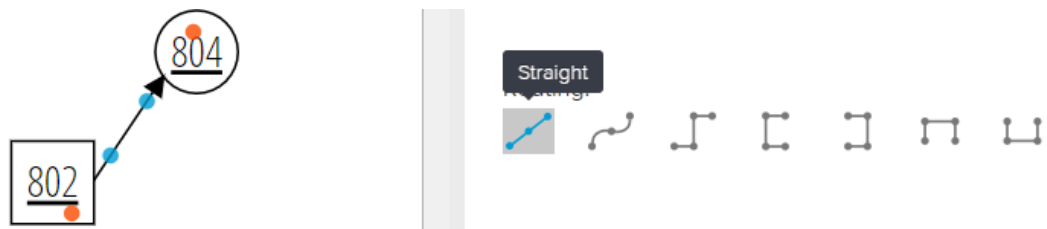

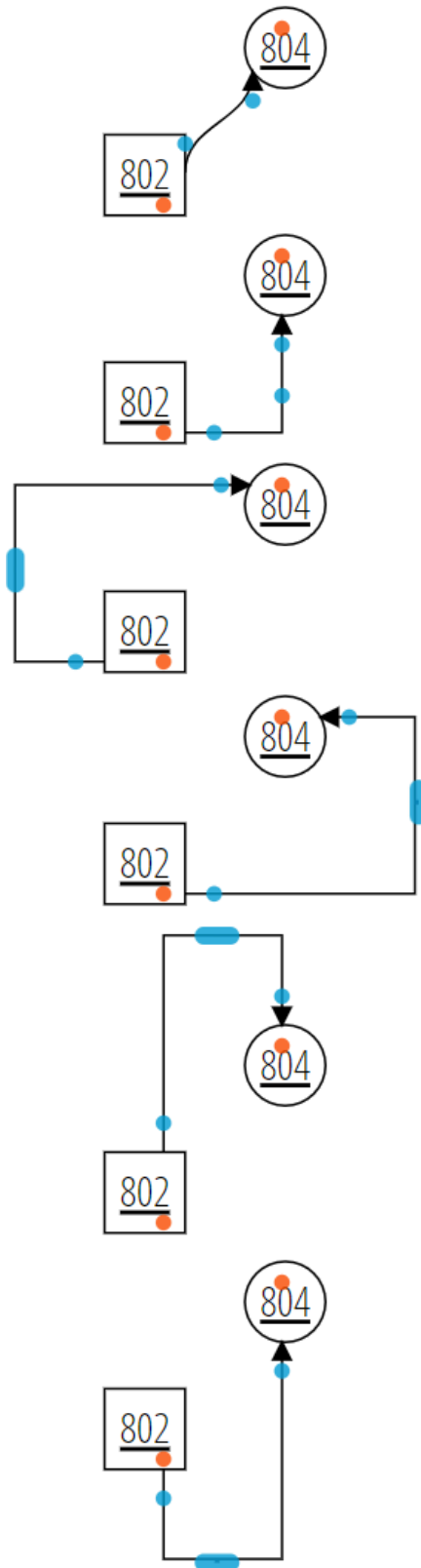



## Adjust How Connector Lines Connect to Stencils

1. Select the desired connector line on the canvas. Anchor (orange) and control (blue) points will be visible when a connector line is selected.
2. Locate the Connect Start and Connect End controls among the Layout controls in the toolbar or right-hand sidebar.
3. Click the Connect start to anchor point control to display the connector line as connecting to the start anchor point instead of the stencil outline.
4. Click the Connect end to anchor point control to display the connector line as connecting to the end anchor point instead of the stencil outline.

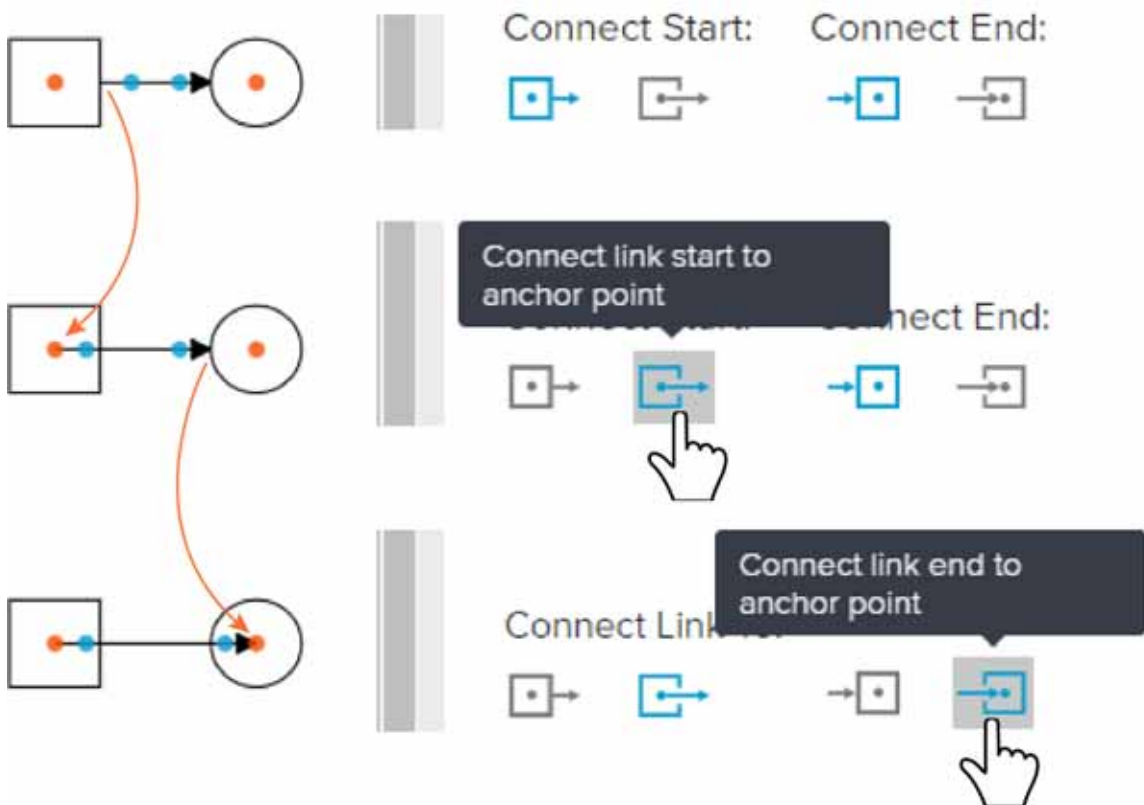

5. Click the Connect start to outline or Connect end to outline controls to display the line as connected to the stencil outline instead of its anchor point.

# Create Flowchart Steps from Stencils

1. Open the Drawing Tool and, if needed, add a new figure on an existing sheet or on a new sheet.
2. Click the Stencils icon to expand the Stencils panel in the left-hand sidebar.

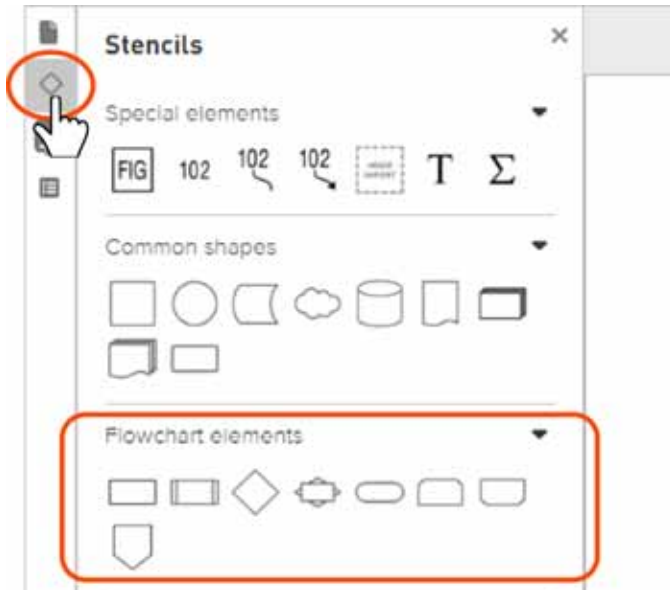

3. Click and drag a Flowchart Elements stencil onto the canvas.

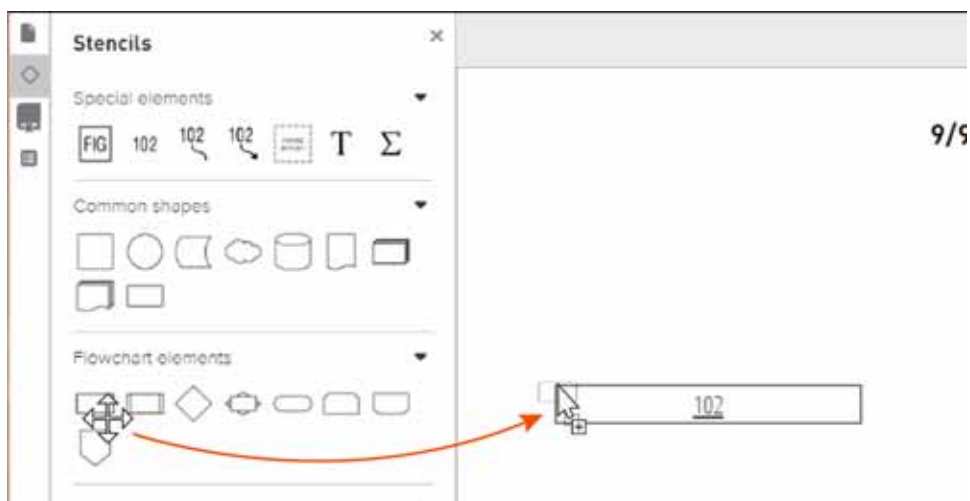

4. Drag additional flowchart stencils and connect them with connector lines as desired OR click the blue arrows around a selected stencil to populate additional, connected stencils of the same type above, below, to the left or right of the selected stencil.

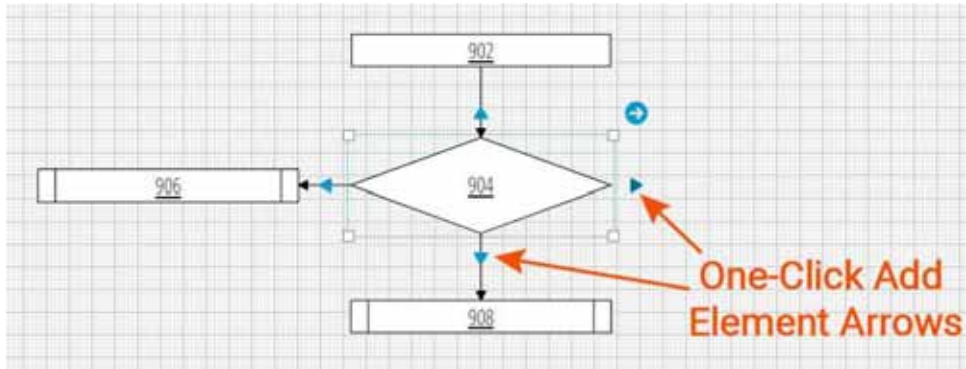

5. Use the stencil edit control as needed to change the type of flowchart element shown for each step.
6. For each element, locate the Element Info controls in the toolbar or right-hand sidebar, and type your desired step descriptions as the stencils' labels



(For more on modifying Element Info fields, see Assign/remove a part number, part name, and label for a stencil or connector line.)

OR select and copy text from the Claims panel using the Copy Selected Text control, then paste it into the desired label field(s). Copied text will be highlighted in the claims panel to help you keep track of what you've added.

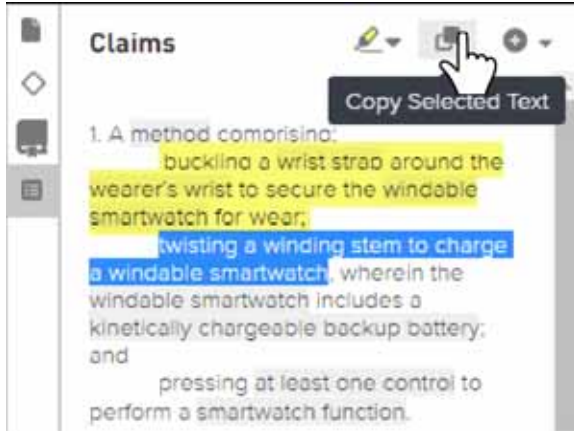

7. Include additional descriptions and a component for each step as desired to provide an enriched autogenerated description.
8. Type or autogenerate a figure description in the specification section for your flowchart figure. An autogenerated description will incorporate the block number and descriptive label for each step in a separate paragraph.

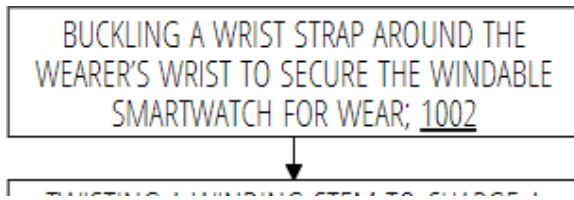

[0037] According to some examples, the method includes buckling a wrist strap around the wearer's wrist to secure the windable smartwatch for wear at block 1002.

## Create Flowchart Steps from the Claims Panel

1. Open the Drawing Tool and, if needed, add a new figure on an existing sheet or on a new sheet.
2. Click the Claims icon to expand the Claims Panel in the left-hand sidebar.

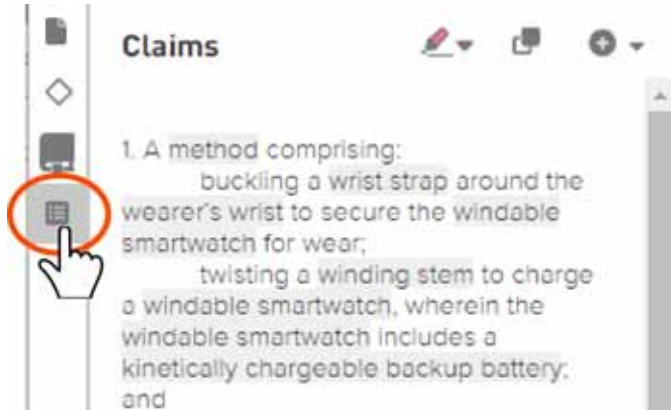

3. Select the desired claim element.

4. Click the Add Flowchart Step option.



5. A flowchart block will be created with the selected claim element included as the block label. That element will be highlighted to show that it has been used in the flowchart.

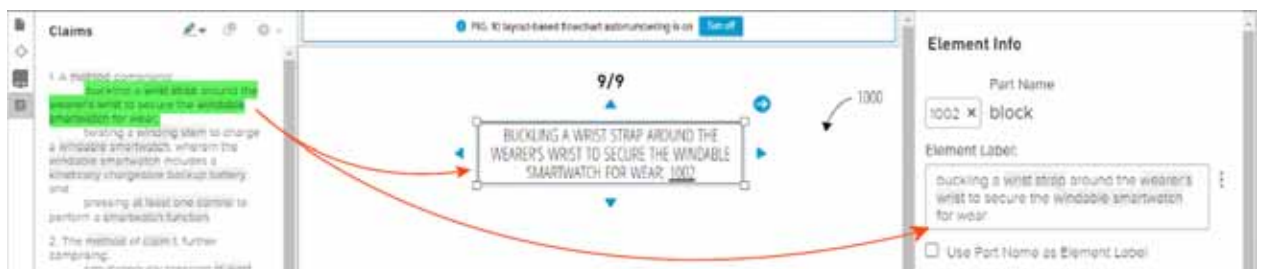

6. Use the stencil edit control as needed to change the type of flowchart element shown for each step.

- Repeat the steps above to create new flowchart stencils connected by connector lines to previous stencils,

OR add additional steps from the Stencils panel and connect them with connector lines manually,

OR click the blue arrows around a selected stencil to populate additional, connected stencils of the same type above, below, to the left or right of the selected stencil.

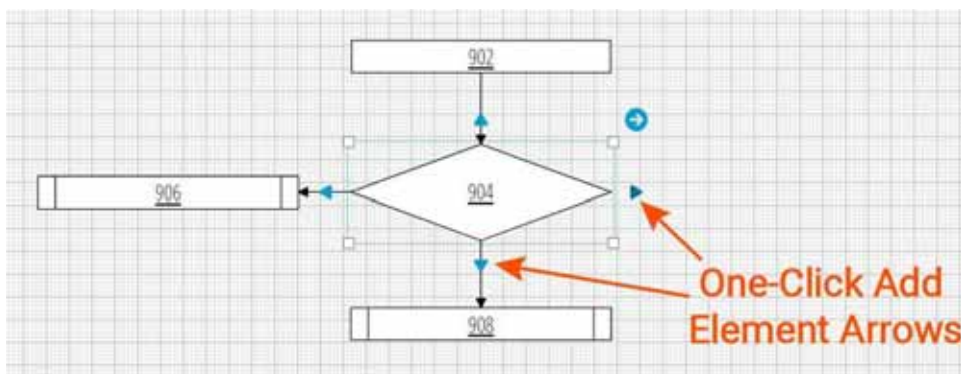

- Include additional descriptions and a component for each step as desired to provide an enriched autogenerated description.
- Type or autogenerate a figure description in the specification section for your flowchart figure. An autogenerated description will incorporate the block name, number, and descriptive label for each step in a separate paragraph.

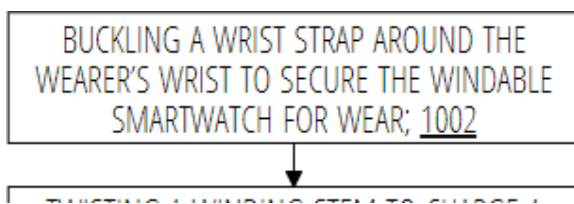

**[0037]** According to some examples, the method includes buckling a wrist strap around the wearer's wrist to secure the windable smartwatch for wear at block 1002.

# Add a Flowchart Step Description

## Include a Basic Description

1. Select the desired flowchart step.
2. Locate the Element Info controls in either the toolbar or the right-hand sidebar and type your desired descriptive text in the Description field provided

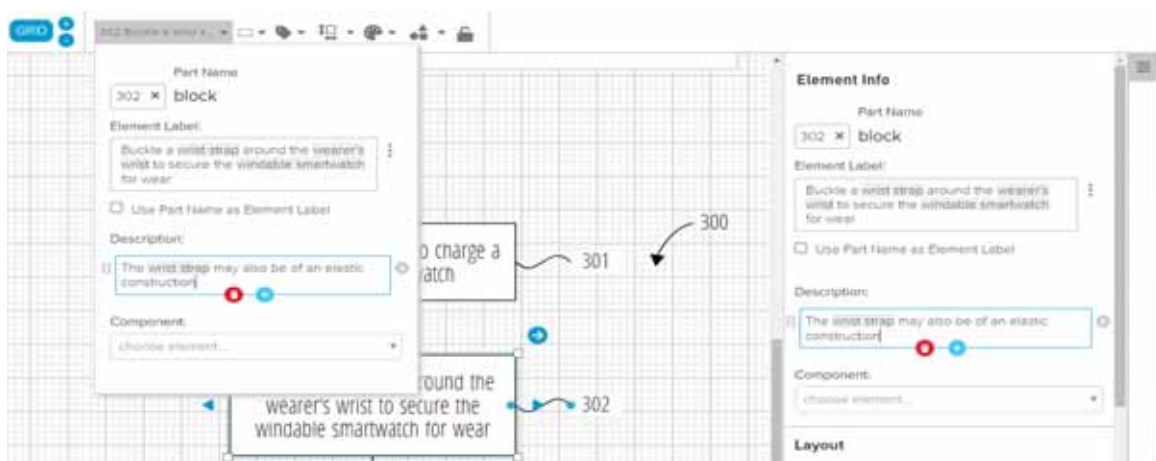

OR select and copy text from the Claims panel using the Copy Selected Text control, then paste it into the description field in the Element Inspector

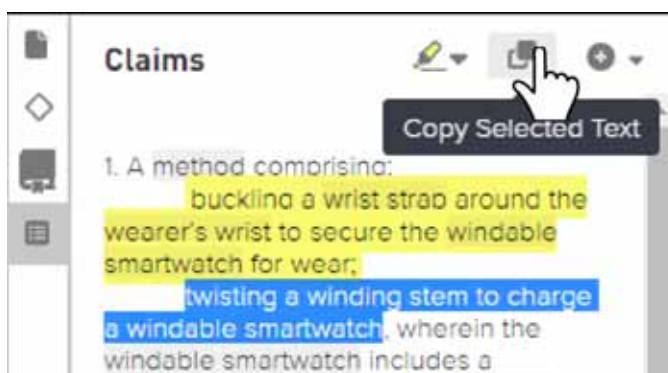

OR select text in the Claims panel and use the Add Flowchart Step or Description dropdown to add that text as the description.

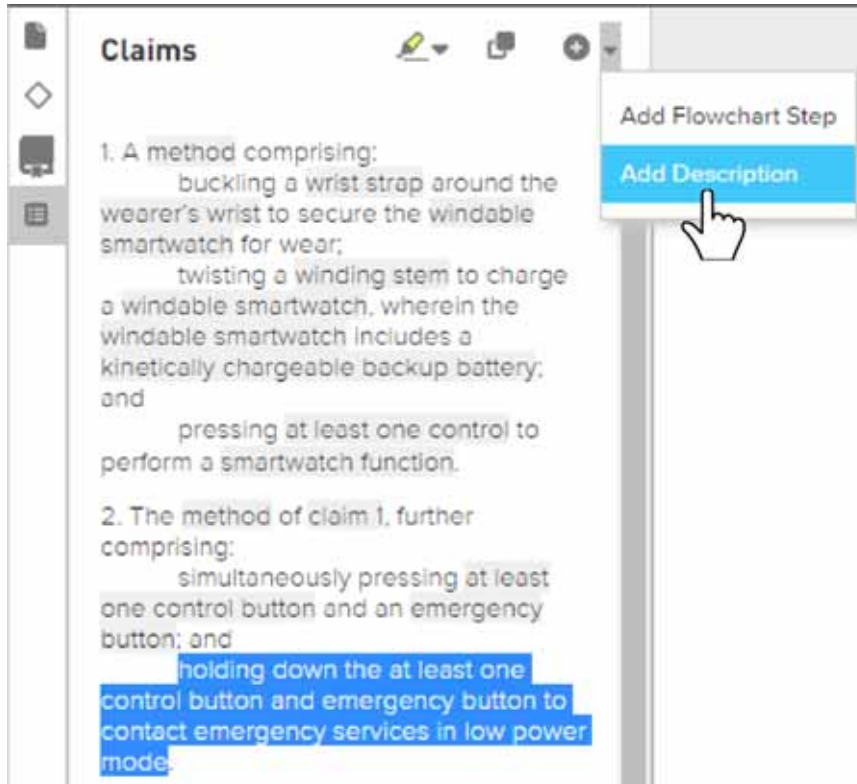

*Text incorporated from the Claims panel will be highlighted to help you keep track of what has been included.*

## Include an Action Description

1. Follow the steps for a basic description above.
2. Click the Action Text control to the right of the description field to designate a description as an Action.

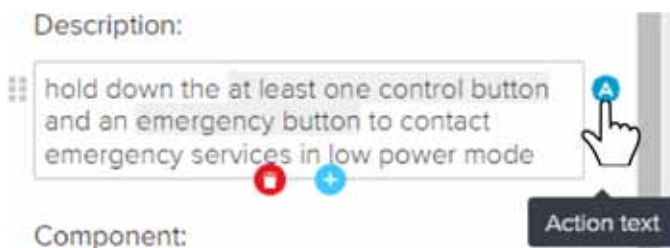

## What's the Difference between Basic and Action Text Descriptions

Description text is incorporated into the autogenerated figure description for the



flowchart figure. Basic descriptive text and action text undergo different transformations when an autogenerated figure description is created.

Example text generated for a basic description is shown here:

BUCKLING A WRIST STRAP AROUND THE WEARER'S WRIST TO SECURE THE WINDABLE SMARTWATCH FOR WEAR 1002

TWISTING A WINDING STEM TO CHARGE A WINDABLE SMARTWATCH 1004

PRESSING AT LEAST ONE CONTROL TO PERFORM A SMARTWATCH FUNCTION 1006

Label Settings

Part Name: block 1004 X

Label: Use Part Name

twisting a winding stem to charge a windable smartwatch

Description: the windable smartwatch may include a kinetically chargeable backup battery

[0038] According to some examples, the method includes twisting a winding stem to charge a windable smartwatch at block 1004. The windable smartwatch may include a kinetically chargeable backup battery.

Example text generated for an action description is shown here:

BUCKLING A WRIST STRAP AROUND THE WEARER'S WRIST TO SECURE THE WINDABLE SMARTWATCH FOR WEAR 1002

TWISTING A WINDING STEM TO CHARGE A WINDABLE SMARTWATCH 1004

PRESSING AT LEAST ONE CONTROL TO PERFORM A SMARTWATCH FUNCTION 1006

Label Settings

Part Name: block 1006 X

Label: Use Part Name

pressing at least one control to perform a smartwatch function

Description: hold down the at least one control button and an emergency button to contact emergency services in low power mode

[0039] According to some examples, the method includes pressing at least one control to perform a smartwatch function at block 1006. According to some examples, the method includes holding down the at least one control button and an emergency button to contact emergency services in low power mode.

## Include Multiple Element Descriptions

1. Select the desired flowchart step.
2. Click the plus sign icon below the existing description field in the Element Inspector.

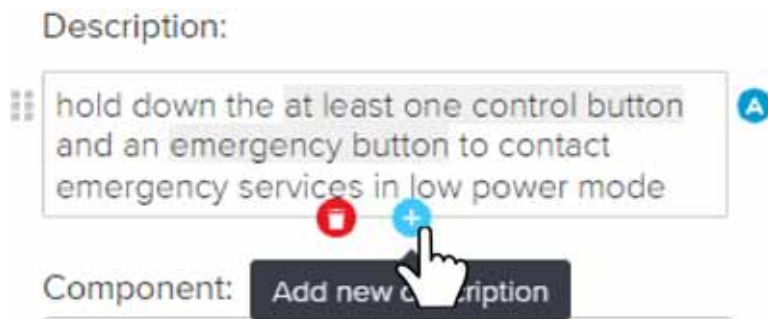

3. Follow the processes above to complete the new description as a basic or action description.
4. Repeat these steps as desired. Each flowchart element may be assigned as many descriptions as you want.

*Note that changes in the Drawing Tool made after a description is autogenerated are not reflected in the specification. The description will need to be regenerated.*

## Reorder Element Descriptions

1. Select the desired flowchart step.
2. Click the Drag to Move icon to the left of the description field in the Element Inspector for the description you want to relocate.
3. Drag the description to the desired location.

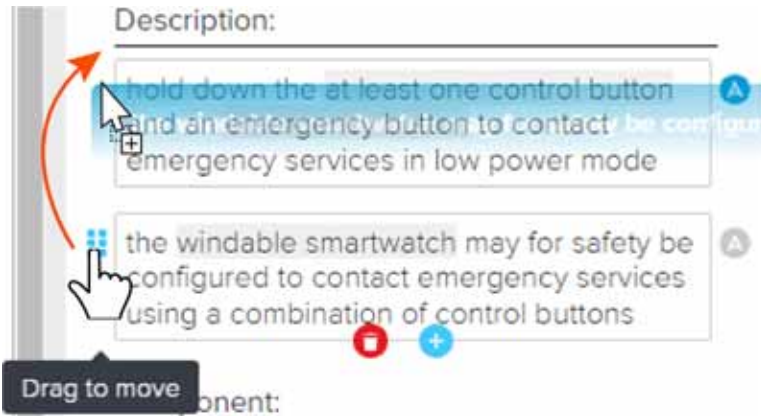

4. When the black insertion point line appears in the desired location, drop the description into its new location.
5. Autogenerated figure description text will include each description in the order in which it appears in the Element Info.

*Note that changes in the Drawing Tool made after a description is autogenerated are not reflected in the specification. The description will need to be regenerated.*

## Delete an Element Description

1. Select the desired flowchart step.
2. Click the trashbin icon below the description you want to delete.



*Note that changes in the Drawing Tool made after a description is autogenerated are not reflected in the specification. The description will need to be regenerated.*

## Add a Flowchart Step Component

1. Select the desired flowchart step.
2. Locate the Element Info controls in the toolbar or the right-hand sidebar.

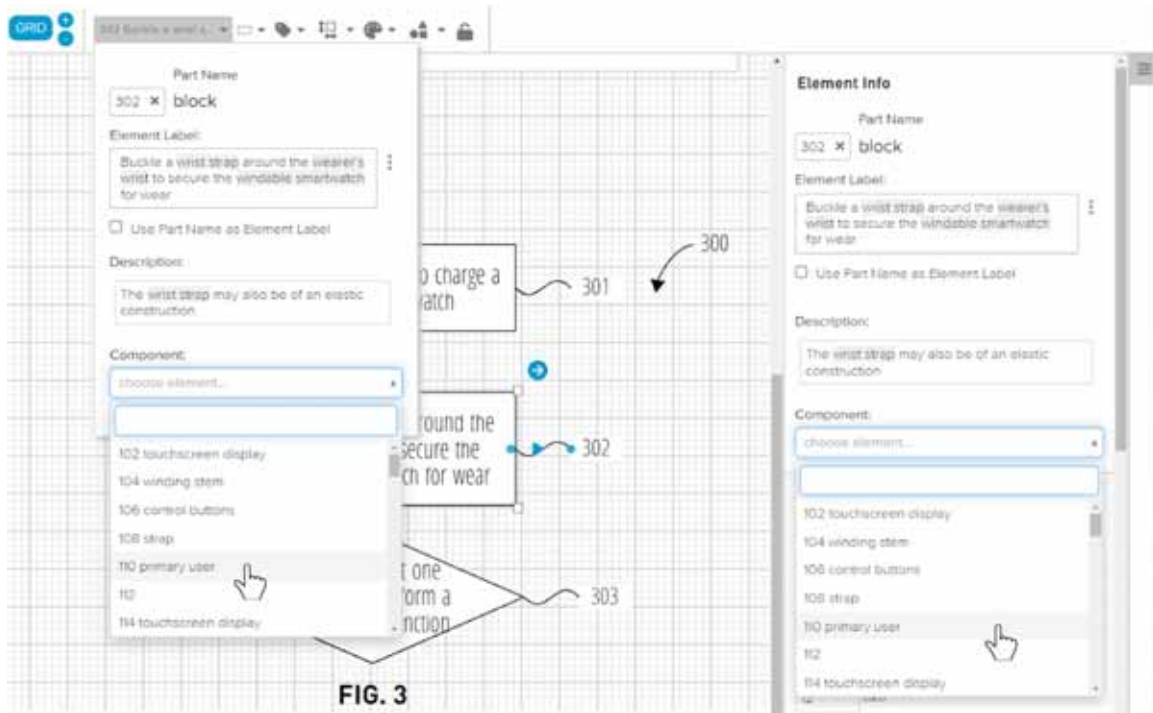

3. Click the Component dropdown control.
4. Select from among the parts in the dropdown.
5. An autogenerated description of your flowchart will include the component in the descriptive paragraph for that step.

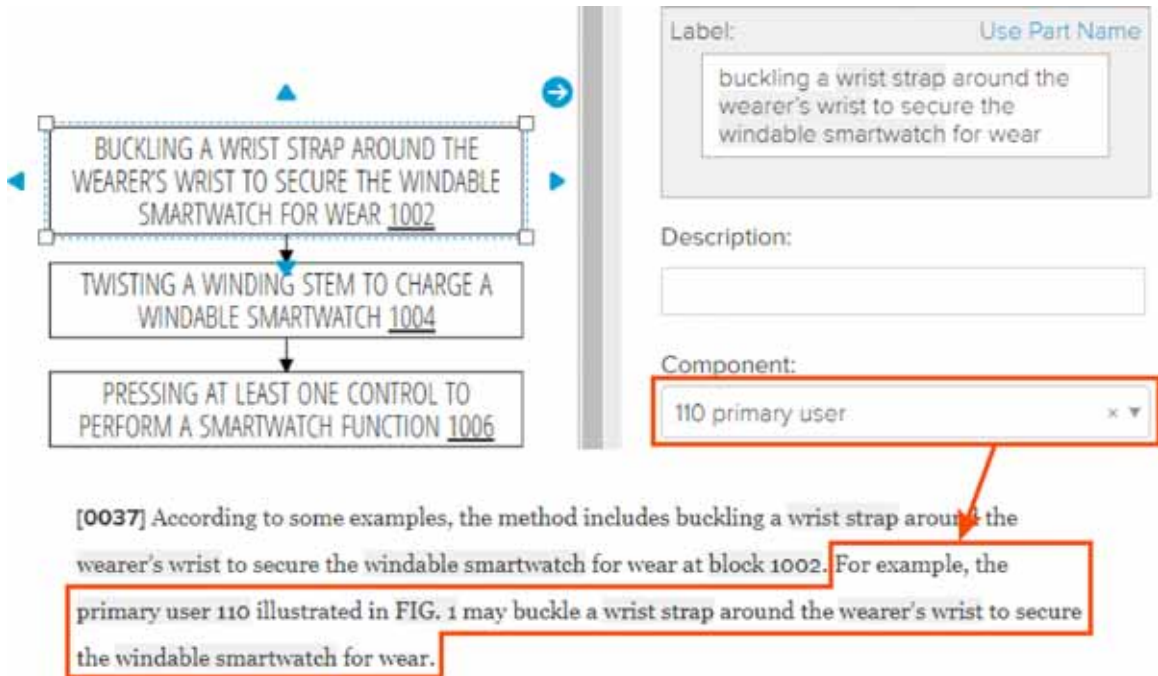

## Adjust Used Element Highlighting in the Drawing Tool Claims Panel

1. Click the Copied Text Highlight Color control at the top of the claims panel.



2. Click one of the color options to change the highlighting color.

*Note that changes will be applied going forward, but not to already highlighted elements.*

3. Click the Turn off highlighting option to stop applying highlighting going forward.
4. Click the Clear all highlights option to remove the highlighting currently applied in the Claims panel.

## Remove/Apply Layout-Based Flowchart Numbering

1. Open the Drawing Tool and navigate to your flowchart.
2. Click the Turn off control above the drawing canvas

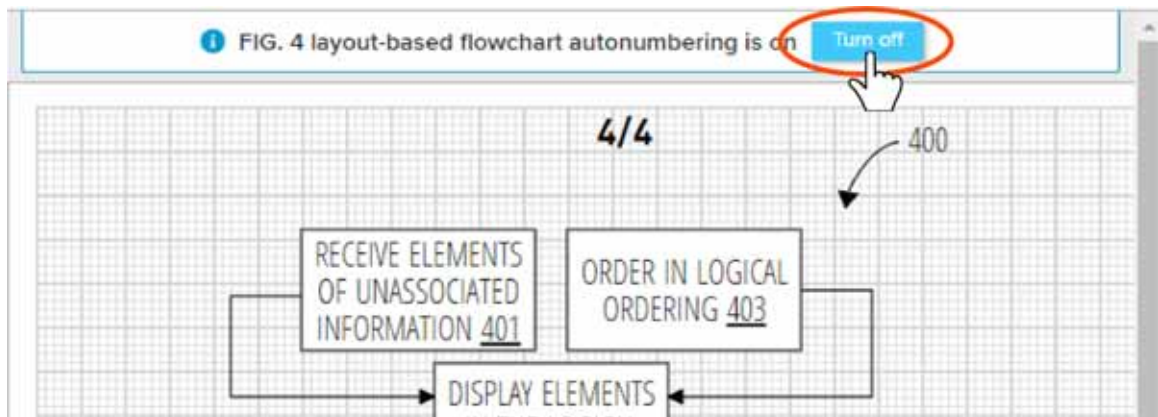

THEN/OR simply reorder that figure's parts in the Parts Panel.



3. Your flowchart elements will now be numbered based on the numbering for their associated parts in the Parts Panel.

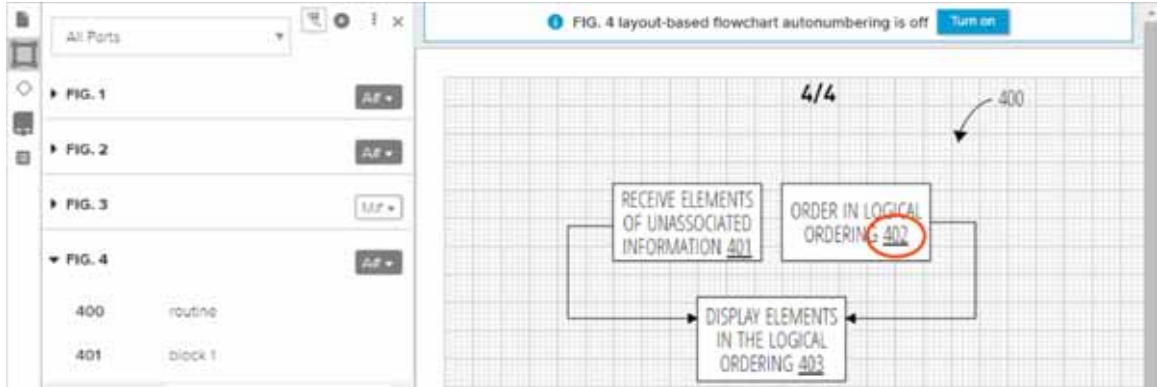

4. To apply layout-based flowchart numbering, navigate to your desired flowchart and click the Turn on control above the drawing canvas.

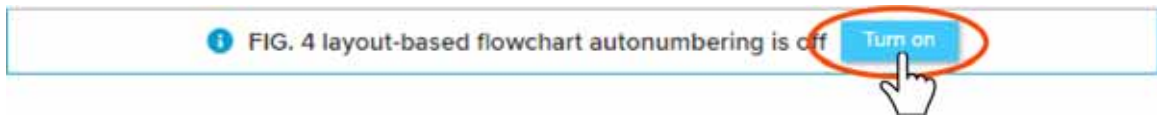

5. Confirm your change in the dialog presented.



6. Your flowchart elements will be numbered based on:
  - the direction of their connecting arrows and
  - where they appear on the drawing canvas, with priority given to top-most elements.

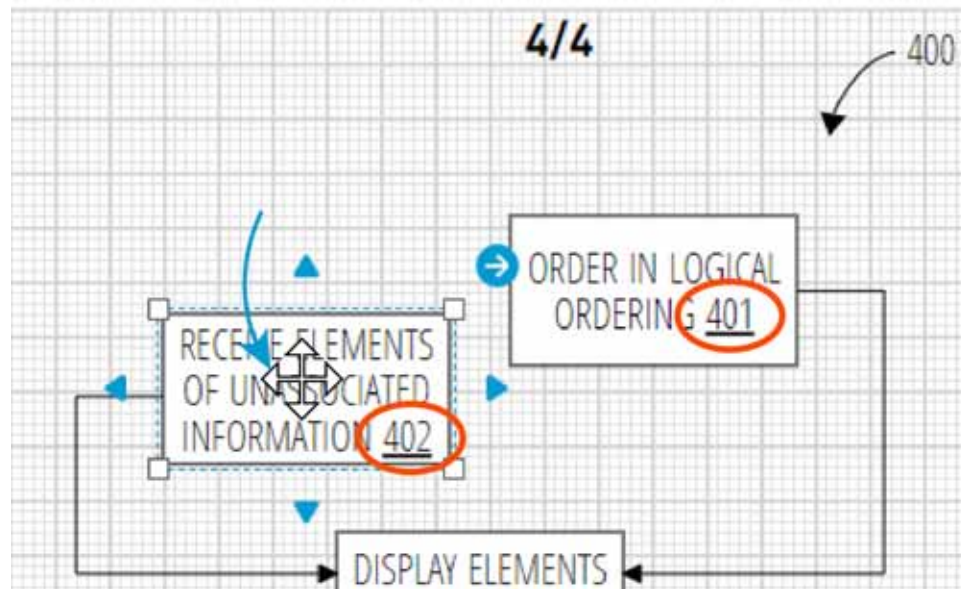

## Add a Mathematical Expression to a Figure

1. Open the Stencils Panel in the left-hand sidebar.
2. Click the Sigma symbol under Special Elements and drag and drop it onto the drawing canvas.



3. Enter your expression in the resulting MathType dialog presented in the lower-right corner of the Drawing Tool.



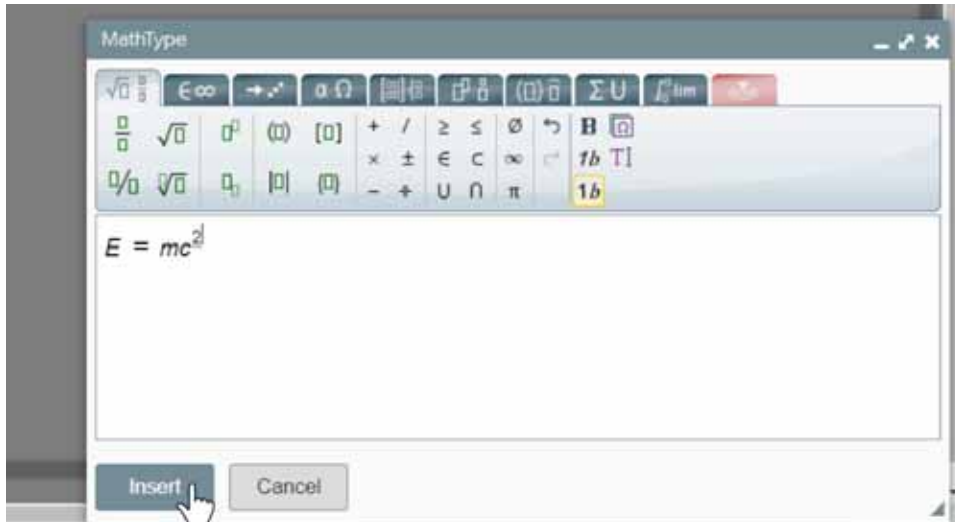

4. Click Insert when your expression is ready.
5. Your mathematical expression will be inserted as a new image stencil with a new part number.

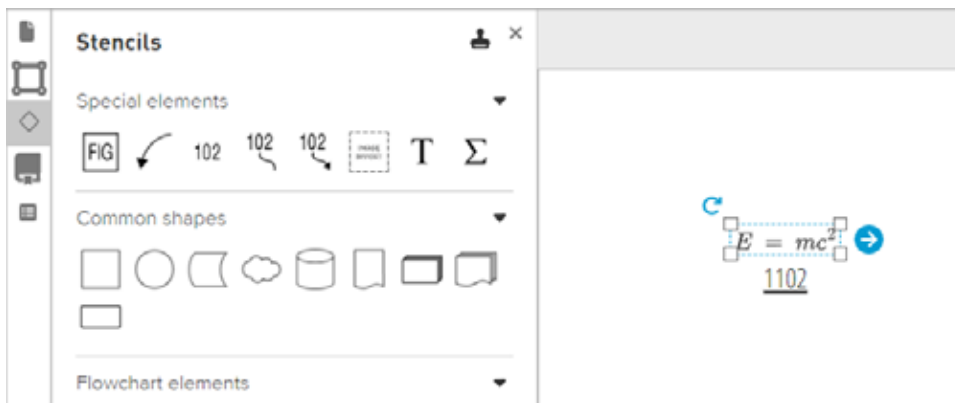

*Note that once inserted, this expression is no longer editable at this time. If you wish to make changes, you will need to create a new expression.*

## Add a Table to a Figure

1. Navigate to or create the figure/sheet where you wish to place a table.
2. Select the Generate Table option under the Import dropdown in the toolbar or the

Drawing menu.

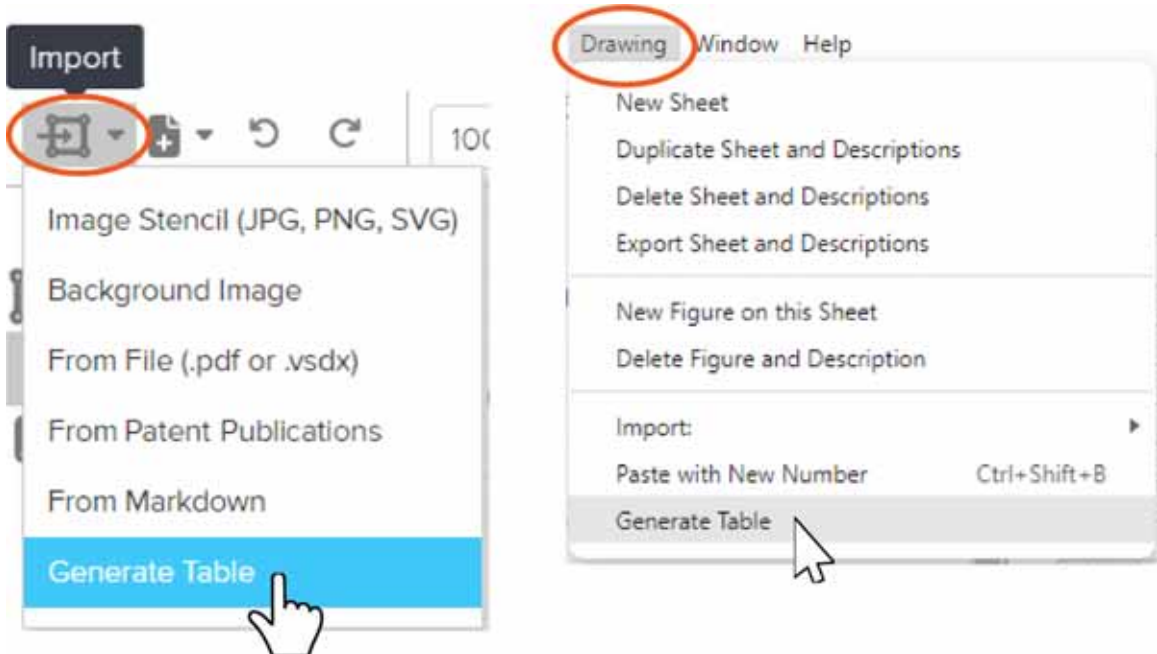

3. Type or use the arrow controls that appear on hover in the resulting dialog to set parameters for number of rows, number of columns, cell width, and cell height.

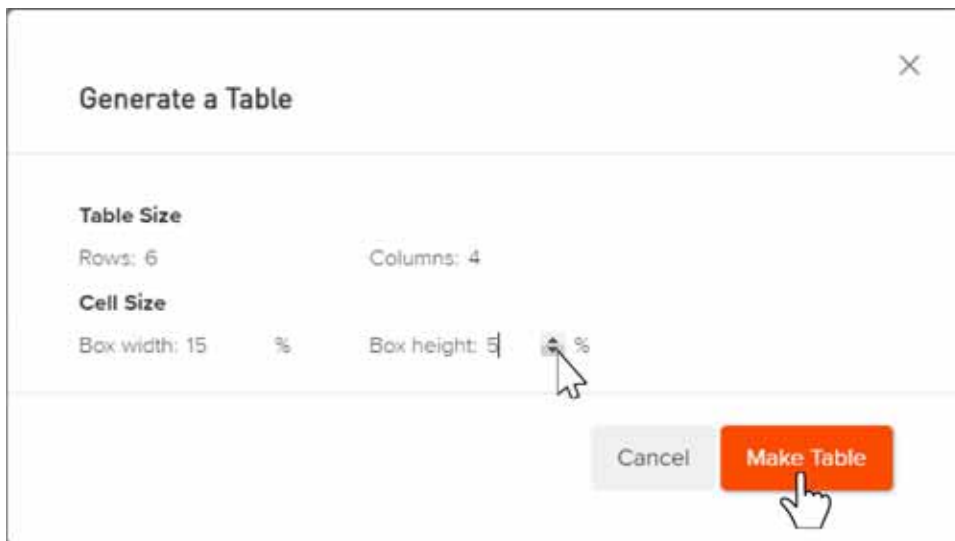

*Note that cell width and height are set as a percentage of page width and height, respectively.*

4. Click the make table button.
5. A grid of rectangles will be inserted based on the parameters you've entered.

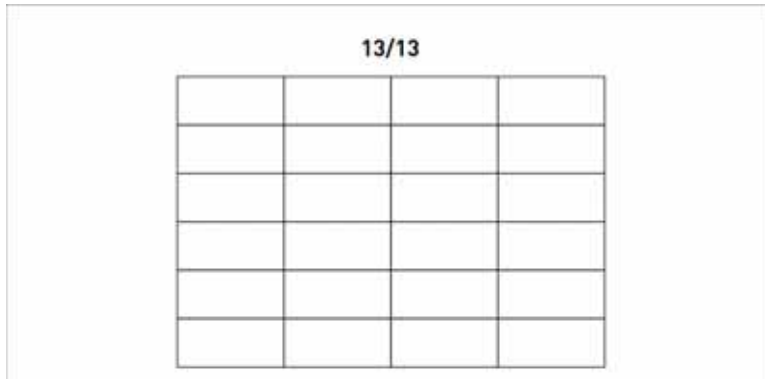

*You may wish to immediately group the inserted table elements to preserve their relative location as you make further changes.*

## Delete a Stencil or Connector Line

### Delete Stencils

1. Select the stencil(s) you wish to delete.

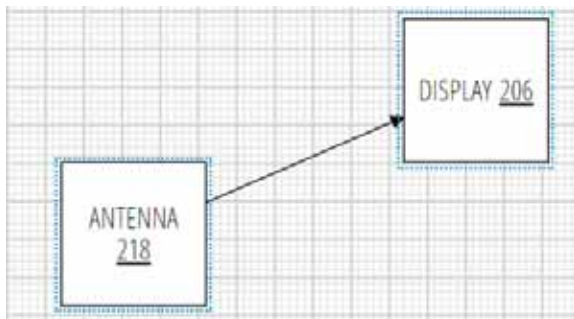

2. Press the Backspace or Delete key on your keyboard.

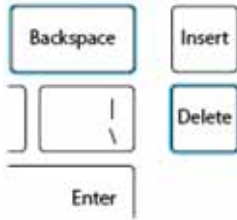

## Delete Connector Lines

1. Select the connector line you wish to delete

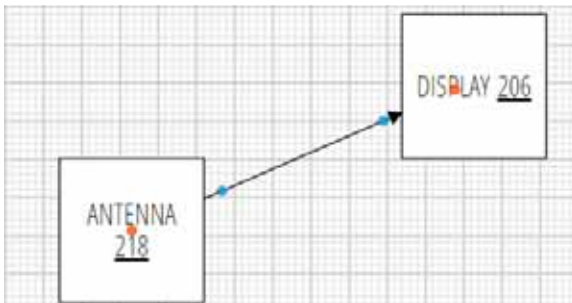

OR select one or both of the stencils anchoring the connector line.

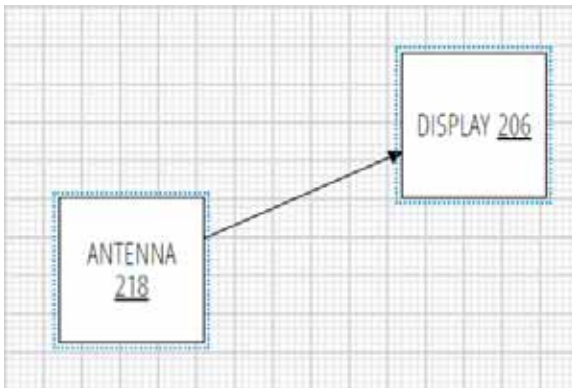

2. Press the Backspace or Delete key on your keyboard.

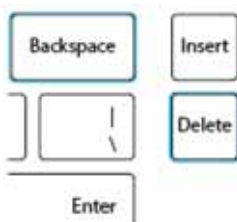

# Get Help or Provide Feedback

1. In any Rowan Patents window, select Rowan Patents Help from the Help menu.

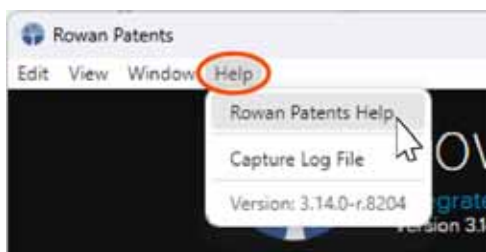

2. Our help interface will open on the right-side of your window.

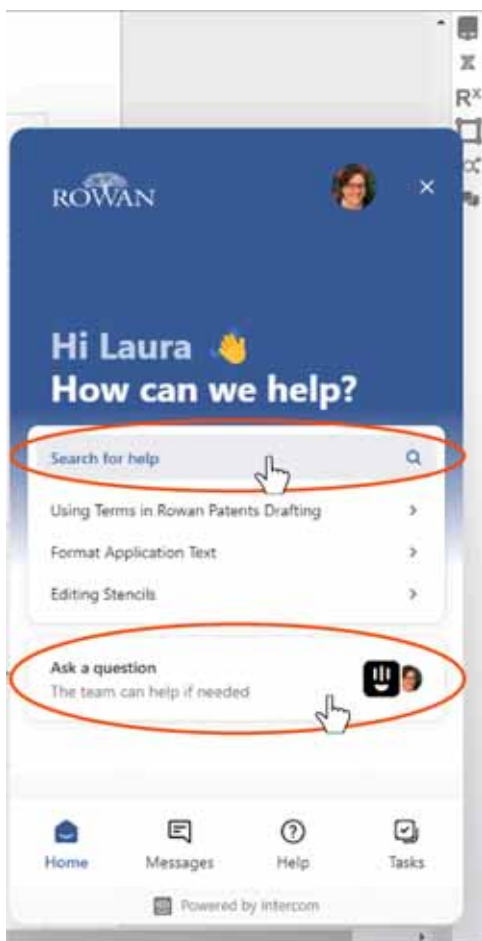

3. Use this interface to search our library of help articles or speak to our support team to ask questions, provide feedback, or report issues.

## Contact Rowan

We are always happy to speak directly with you to address any questions, feedback, suggestions, or requests you may have. In addition to the steps above, you can reach out to us as follows.

- Provide feedback and request features at [feedback@rowantels.com](mailto:feedback@rowantels.com)
- Contact our Customer Success Practitioner at [skirkwood@rowantels.com](mailto:skirkwood@rowantels.com)
- Request a 15, 30, or 45 minute informational or help session using the links below:
  - <https://meet.intercom.com/skirkwood/15min>
  - <https://meet.intercom.com/skirkwood>
  - <https://meet.intercom.com/skirkwood/45min>

All information in this manual is also available and evergreen in our online help library at

<https://intercom.help/rowanpatents/en/collections/1625737>